

SC

8 7 6 5 4 3 2 1

STATUS OF REVISIONS				
SH	DATE	DESCRIPTION	DATE	APPROVED
2				

NOTES:

- ALL FABRICATION WELDING AND INSPECTION TO BE IN ACCORDANCE WITH NAVSEA 0900-LP-014-5010, WELD SIZES BASED ON USE OF AWS A5.1, CLASS E7018 ELECTRODES FOR LC STEEL TO LC STEEL.
- TEMPLATE ALL WORK FROM LCM-8 AND EQUIPMENT.
- EQUIPMENT AND WORKMANSHIP SHALL BE IN ACCORDANCE WITH USCG AND ABS REGULATIONS.
- REPAIR ALL PAINT DAMAGED BY THIS INSTALLATION AND PAINT ALL NEW STEEL IN ACCORDANCE WITH U.S. ARMY TECHNICAL BULLETIN TB43-0144.
- MATERIAL ORDERED ON THIS DRAWING IS NOT INTENDED TO BE RESTRICTIVE. SUBSTITUTION OF EQUAL QUALITY MATERIAL MAY BE MADE EXCEPT ITEMS MARKED GFE.
- SLIGHT DEVIATIONS FROM DIMENSIONS SHOWN ARE PERMISSIBLE TO SUIT ACTUAL CONDITIONS FOUND ABOARD THE VESSEL.
- COMPONENTS SHOWN BY SOLID, HEAVY LINES ARE NEW AND ARE TO BE INSTALLED IN ACCORDANCE WITH THIS DRAWING. PHANTOM LINES INDICATE EXISTING COMPONENTS INSTALLED BY DRAWINGS REFERENCED AS NOT D.
- PROJECTING CORNERS AND EDGES TO BE WELL ROUNDED OR PADDED TO PROTECT PERSONNEL.
- EXISTING PIPING TO BE SHORTENED TO OBTAIN NEW POSITIONS OF THE HYDRAULIC RESERVOIR AND RETURN LINE FILTER.
- REMOVE LONGITUDINAL STRUT BETWEEN BHD 39 AND FR 35.
- PRIOR TO ALL WELDING, BURNING OR OTHER HOT WORK, THE WORK AREA SHALL BE MADE "SAFE FOR MEN - SAFE FOR FIRE" IN ACCORDANCE WITH OSHA SAFETY AND HEALTH REGULATIONS (29 CFR 1915). HYDRAULIC TANK AND LINES SHALL BE DRAINED AND THE TANK CLEANED, WASHED AND STEAMED OUT OR OTHERWISE MADE SAFE IN ACCORDANCE U.S. ARMY TECHNICAL BULLETIN TB750-1047.
- USE EXISTING PIPE REMOVED DURING MOVING OF TANK, IN AREAS INDICATED.
- EXISTING TANK FOUNDATIONS SHALL BE COMPLETELY REMOVED. GRIND OFF ANY EXISTING HIGH POINTS.
- REMOVE (2) EXISTING LEVEL INDICATORS, PLUG HOLES WATERTIGHT AND GRIND FLUSH.
- STENCIL LETTERING AS SHOWN LETTERING TO BE BLACK, TO HEIGHT INDICATED, POSITIONED APPROXIMATELY AS SHOWN.
- ALL INSIDE BEND RADII SHALL BE 1/4" MAX.

REFERENCE DRAWINGS APPLICABLE TO HULL NUMBERS 8540 THRU 8560 AND 8580 THRU 8518		
NO.	DRAWING NO.	TITLE
1	13226E9466	LCM-8, MOD 1, MOD TO RAMP HYD SYS
2	145-4510921	LCM-8, MOD 1 DETAILS BULKHEAD AND TRANSOM
3	145-4510943	LCM-8, MOD 1 HYD RESERVOIR RAMP HOIST STEERING

REFERENCE DRAWINGS APPLICABLE TO HULL NUMBERS 8520 THRU 8539		
NO.	DRAWING NO.	TITLE
1	13226E9466	LCM-8, MOD 1, MOD TO RAMP HYD SYS
2	145-2534195	LCM-8, MOD 1 BULKHEAD AND TRANSOM
3	145-2534226	LCM-8, MOD 1 HYD RESERVOIR RAMP HOIST STEERING

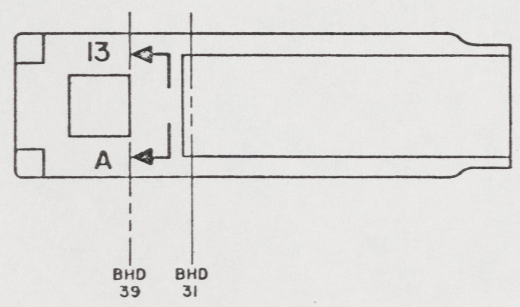

KEY VIEW  
PLAN 6-A

THIS DRAWING APPLIES  
TO HULL NUMBERS  
8520 THROUGH 8560 AND  
8580 THROUGH 8618 ONLY

YARD	ITEM NO.	QTY	DESCRIPTION	SPECIFICATION	MATERIAL
YARD 11		1	PLATE, 1/4" THK	ASTM A36	STEEL
YARD 1C		1	PLATE, 1/4" THK	ASTM A36	STEEL
YARD 9		1	PLATE, 1/4" THK	ASTM A36	STEEL
YARD 6		1	PLATE, 3/16" THK	ASTM A36	STEEL
YARD 7	NS35338-141	4	LOCK WASHER, 3/8 NOM SIZE		CRES
YARD 8	NS35307-358	4	SCREW, CAP, HEX-ND, 3/8-16 UNC-2A X 3/4 L		CRES
YARD 5		4	UNION PIPE, THREADED, 1/2" IPS, MALE/FEMALE, CLASS 150	ANSI B16.39	M.I.
GFE 4	04034	2	LIQUID LEVEL INDICATOR, 1/2" NPT CONN, 13" OF INDICATION (GENS)	COHL	CRES
YARD 3		1	PLATE, 1/2" THK	ASTM A36	STEEL
YARD 2		1	CAP, 3/4" IPS, 180 LB, CLASS 150	ANSI B16.3	M.I.
YARD 1	71177	1	TANK FLANGE, 200ND, 1/2" PIPE SIZE (BUCKEYE)	COHL	F63 STL

PARTS LIST		U.S. ARMY MOBILITY EQUIPMENT RESEARCH AND DEVELOPMENT COMMAND FORT BELVOIR, VIRGINIA 22060	
<p>UNLESS OTHERWISE SPECIFIED DIM/TOLERANCES ARE: — IN.</p> <p>ONE PLACE (1.0) ± — TWO PLACE (1.00) ± — THREE PLACE (1.000) ± — ANGLES ± —</p> <p>DO NOT SCALE THIS DRAWING</p> <p>FOR INTERPRETATION OF DRAWING DIMS 118-108 APPLIES</p> <p>REMOVE SHARP AND BREAK SHARP TOOLS</p> <p>SHARP EDGES — 18 — FILLET RADIUS — 18 —</p> <p>MATERIAL</p>	<p>DRAWN BY: JCB</p> <p>CHECKED BY: C.V. Flinn</p> <p>DATE: 15 Oct 88</p> <p>CONTRACT NO.</p>	<p>DATE: 18 OCT 84</p> <p>DATE: 15 Oct 88</p> <p>DATE: 15 Nov 88</p> <p>DATE: 15 Oct 88</p>	<p><b>LCM-8, MOD-1, MODIFICATIONS TO HYDRAULIC RESERVOIR, RAMP / HYDRAULIC START</b></p> <p>SIZE: A1</p> <p>FIG: 97403</p> <p>DWG NO: 13226E9467</p> <p>SCALE: 1/2" = 1'-0"</p> <p>SHEET 1 OF 2</p>

67

8 7 6 5 4 3 2 1

16 15 14 13 12 11 10 9

NO.	REV.	DESCRIPTION	DATE	APPROVED

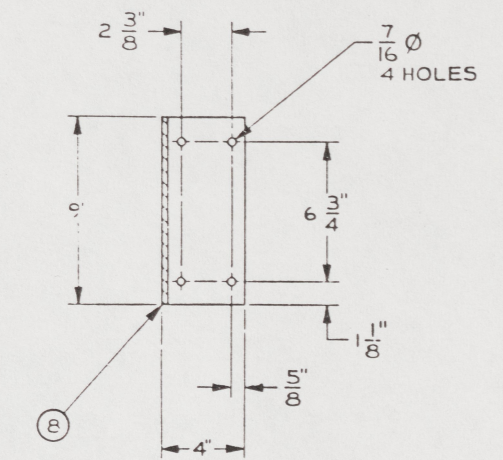

SECTION 15-C  
SCALE 3" = 1'-0"

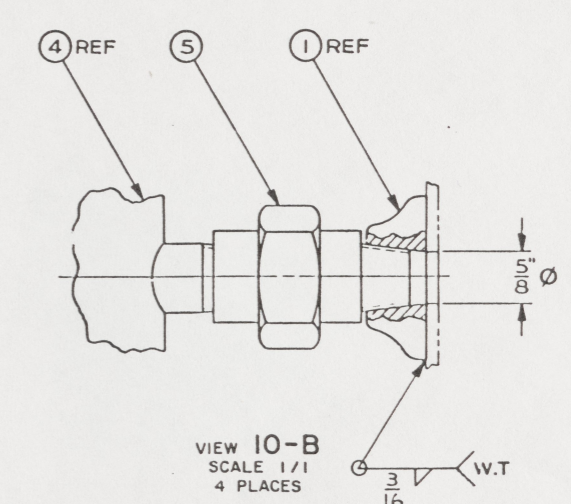
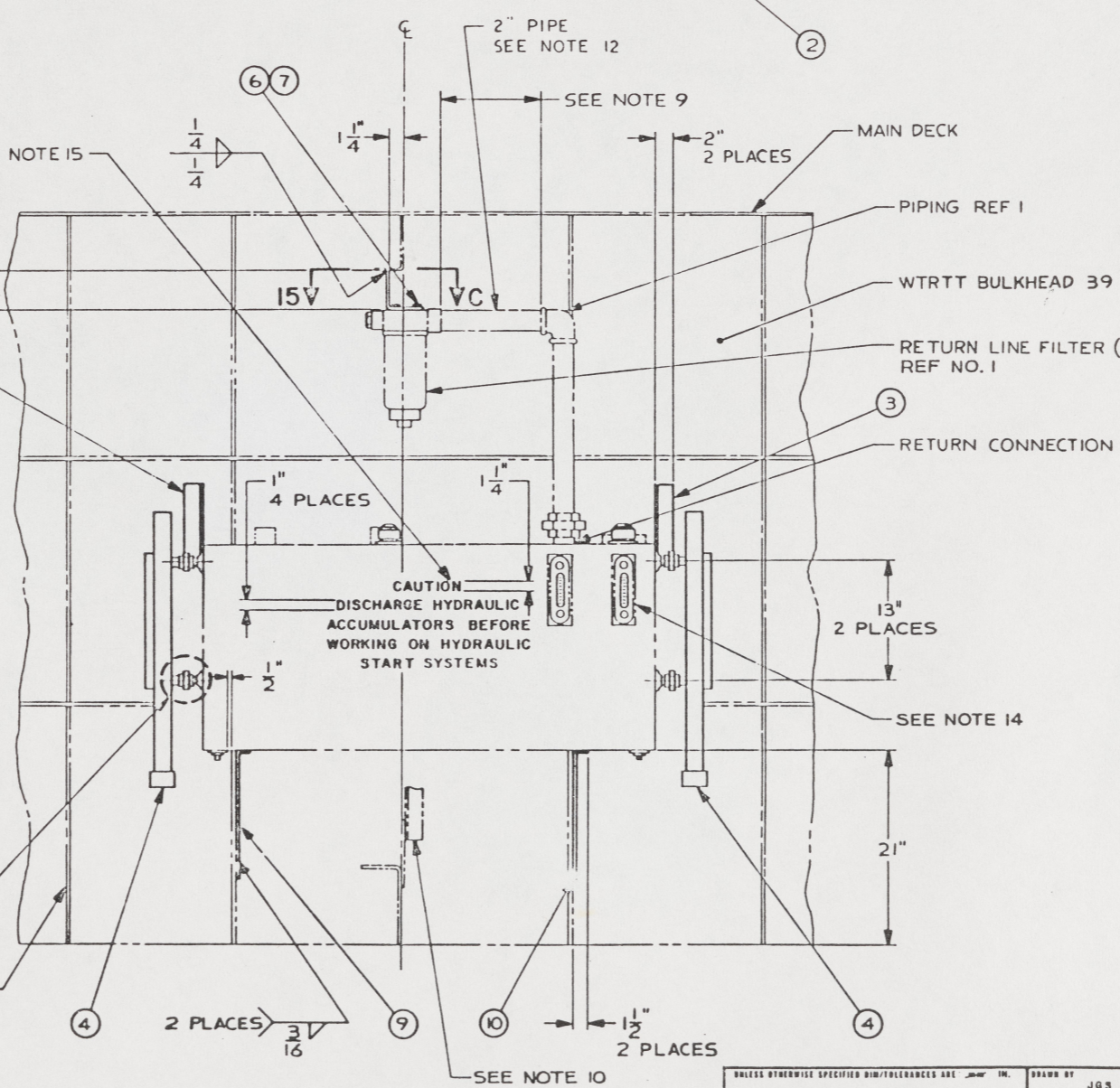
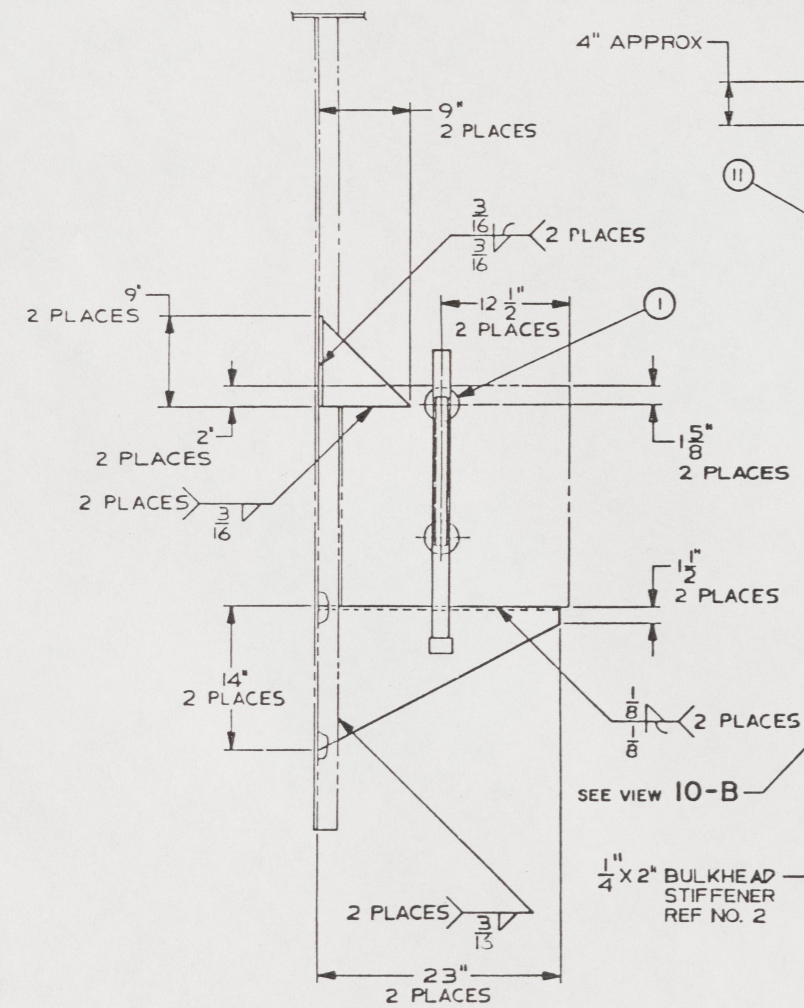
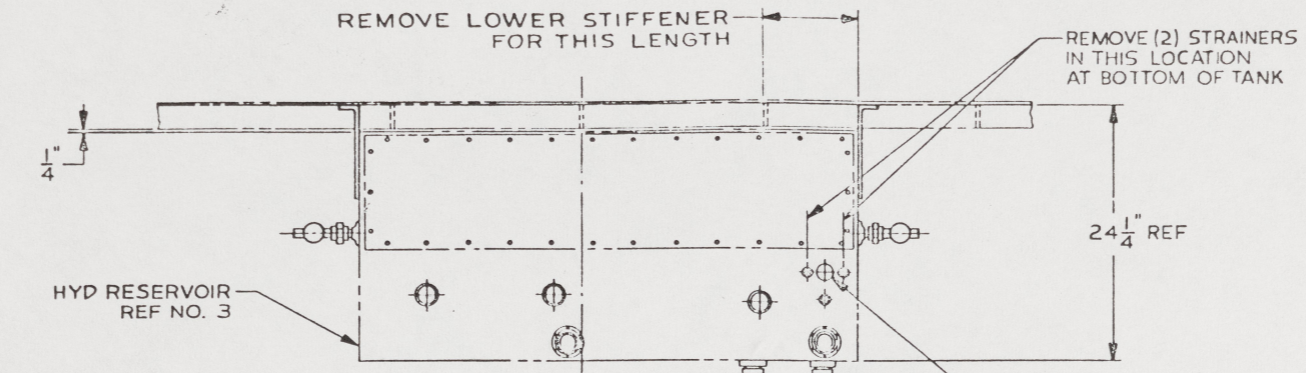

VIEW 10-B  
SCALE 1/1  
4 PLACES

VIEW 13-A  
(6-B)  
RELOCATION OF HYDRAULIC RESERVOIR  
CLOSER TO CENTER LINE OF BOAT  
ROTATED 90° CW

UNLESS OTHERWISE SPECIFIED DIM/TOLERANCES ARE IN INCHES		DRAWN BY JOS	DATE 19 OCT 84	U.S. ARMY MOBILITY EQUIPMENT RESEARCH AND DEVELOPMENT COMMAND FORT BELVOIR, VIRGINIA 22060	
ONE PLACE (1 X) 2	TWO PLACE (2 X) 2	CHECKED BY CY Pardo	DATE 15 NOV 88	LCM-8, MOD-1, MODIFICATIONS TO HYDRAULIC RESERVOIR, RAMP / HYDRAULIC START	
THREE PLACE (3 X) 2	ANGLES 2	THIRD ANGLE PROJECTION	CONTRACT NO.		
DO NOT SCALE THIS DRAWING FOR INTERPRETATION BY DRAWING/DOCS FOR APPLIES		DESIGN APPROVAL Robert M. Smith		SIZE A1	PSCN 97403
REMOVE CORNERS AND BREAK SHARP EDGES CHAMF EDGES TO FILLET CORNERS TO		DATE 18 Nov 88		APP'D NO 13226E9467	SCALE SHEET 2
MATERIAL		APPROVED FOR PROCUREMENT George H. P. [Signature]		DATE 10 Nov 88	

68

16 15 14 13 12 11 10 9