

Suggests Govm't By Bribery

KNOXVILLE, Tenn. (AP) — The American electoral process is, in effect, government by bribery, says pollster George Gallup.

"We presently hear of international business being probed for alleged bribery incidents. But when we think about it, when a candidate goes out and promises a group something, it really is bribery also," Gallup told a University of Tennessee audience Wednesday night.

"Those promises create new programs and sometimes cost hundreds of thousands of dollars," Gallup continued. "I think

people need to get around to saying that such promises are acts of bribery."

The pollster suggested nationwide primaries by the two major political parties for picking presidential nominees. He said this would save time and money and "give the public a much better chance to provide parties with a true assessment of candidates."

Gallup also said his poll indicates former Georgia Gov. Jimmy Carter would be a more formidable Democratic candidate for President than Minnesota Sen. Hubert Humphrey.

Funds Retained For Human Rights Body

RALEIGH (AP)—A legislative budget committee has changed its mind about shutting down the North Carolina Human Rights Commission in an effort to save money.

In other action Wednesday the committee refused to raise the size of kindergarten classes and voted to close the Richard T. Fountain Training School for juvenile delinquents in Rocky mount.

The committee agreed to recommend that the Human Rights Commission's \$379,000 budget be cut by \$150,000. With members saying the commission had outlived its usefulness, the committee voted last week to eliminate the appropriation entirely.

The decision to reconsider came after Ronald K. Ingle, director of the commission, defended his agency's work. He said, "we have good credibility out there, among people in the field."

Since it began work last Wednesday, the committee has

identified about \$43 million of possible cuts in the state budget for 1976-77. It is trying to find funds to increase some appropriations and to provide a pay hike for teachers and state employees.

The committee divided along Senate-House lines in rejecting a move to increase size of kindergarten classes by three to 29. A slim majority of the House members were willing to accept the proposal, but Senate members of the joint committee opposed it.

Although it rejected the increase in class size there were indications the committee might recommend cuts totaling \$3.6 million in the kindergarten program. The money saved would be used to provide more kindergarten classes to allow about 70 per cent of the eligible youngsters to attend kindergarten next September instead of 65 per cent as planned.

To counter the move to increase class sizes, the Department of Public Instruction proposed a \$300,000 cut in the allowance for kindergarten materials, a cut of \$1.6 million in funds not needed for salaries, and a cut of \$944,656 not needed for pupil transportation.

The committee completed its work on the budget for the Department of Human Resources and recommended about \$14 million in cuts. These included closing the Fountain school, which would save \$940,000, delaying \$2.4 million worth of construction at Dorothea Dix Hospital, and eliminating \$1.2 million for construction at the Stonewall Jackson Training school in Concord.

Director Raymond Shurling of the training school program,

told the lawmakers that enrollment at the school had declined to the point where "construction is unwarranted."

The committee agreed to restore \$2.1 million for pollution control devices at the University of North Carolina at Chapel Hill steam plant.

It rejected a move that would have paved the way for the General Assembly to take control of as much as \$21 million expected from the sale of the utilities at UNC-Chapel Hill. University officials have expected the money from the sale to remain in the hands of the university.

With Sen. Ralph Scott, D-Alamance, leading the way, the committee rejected a proposal

by Rep. C. Kitchin Josey, D-Halifax, requiring 50 per cent of any receipts from the sale during the coming fiscal year to revert to the general fund, instead of a special capital fund for UNC-Chapel Hill set up by the 1971 General Assembly. The utility sale is expected to bring about \$42 million.

Josey argued that under the present arrangement the General Assembly has no control over the way monies from such sales are used.

Scott said he could not go along with splitting the proceeds equally between UNC and the general fund. He called for a subcommittee to study the problem.

'Ultimatum' By Leftists

By HARRY DUNPHY
Associated Press Writer

BEIRUT, Lebanon (AP) — The left-wing Moslem Alliance today gave Christian President Suleiman Franjeh 10 days to leave office and threatened to establish a revolutionary government by force if he doesn't.

"If a solution is not found to the crisis, the Lebanese nationalist movement will be obliged to form a revolutionary government to handle control of areas under it and liberate other areas," the Alliance said in a statement broadcast by Beirut radio.

The Alliance, a grouping of leftist forces fighting the right-wing Christian Phalangists, also threatened to establish a

nonsectarian assembly to draw up a new constitution.

It warned Franjeh if he stalled any longer over quitting it would mean he was trying to internationalize the crisis and thereby partition Lebanon.

Lebanon's parliament has passed a constitutional amendment allowing Franjeh, a symbol of Christian resistance, to step down, but so far he has not.

Lebanon's year-long civil war — which has claimed more than 16,500 lives including 86 Wednesday and early Thursday — is over demands by the Moslem majority for more political and economic control.

Sixteen Hurt In Bomb Blast

BOSTON (AP) — A bomb ripped through a probation office on the second floor of the Suffolk County Courthouse today, injuring at least 16 persons, authorities said. One man lost a leg in the explosion, police said.

Officials said they were warned of the bomb by an anonymous woman caller who gave "ethnic connotations which I don't want to mention," said John Powers, clerk of the state Supreme Court.

He said the caller referred to the case of Anthony Jackson, who is accused of murdering several Boston area coeds about two years ago.

Authorities said that the call came exactly 20 minutes before the explosion, and a voluntary evacuation was begun. But

some workers chose to stay inside the building, believing the warning to be a hoax. Powers said more than 50 bomb threats were received in the 19-story building within the last year.

Fountain is the ranking majority member of the House Government Operations Committee which investigates federal agencies and is a member of the House International Relations Committee.

He also supports revenue sharing and called it "the only federal grant-in-aid program which really permits local people through their elected public officials to make their own decisions as to the best way to use at least some of the money they send to Washington."

"I was very, very scared, and I ran," she said. "I'm not used to this type of thing."

The blast tore away a 20-foot section of wall separating the office from a corridor and blew a hole through the floor into the lobby below.

"It must have been one hell of a bomb," said one Boston police officer. "It ripped everything to shreds."

Williamston — The Mid-East Commission's Emergency Medical Services Council met here last night in a re-organizational session and elected Terry Barber of Route 1, Jamesville, as chairman for the coming year.

Barber replaces Stuart Savage of Greenville, who has served as chairman since the EMS council was organized two years ago. In addition to Barber, an

employee of the Williamston Rescue Squad, Norma Faye Lewis of Greenville was elected as chairman of the council. Ms. Lewis is a registered nurse at Pitt Memorial Hospital.

The purpose of the EMS council is to conduct longrange planning and implementation programs to improve emergency medical services in the five-county Mid-East region — State Planning Region Q.

Kissinger To Unveil Aid To Black Africa

WASHINGTON (AP) — Secretary of State Henry A. Kissinger plans to meet with leaders of Rhodesia's black majority and to outline a stepped-up U.S. aid program during his trip to Africa to demonstrate American support for the aspirations of blacks throughout the continent.

U.S. sources said the meeting with leaders of the African National Council — ANC — will take place next Monday or Tuesday when he stops in Zambia, the third African country on his two-week itinerary. The session is intended to point up U.S. opposition to Rhodesia's suppression of its black majority.

However, the most important leader of the ANC, Bishop Abel Muzorewa, announced in Zambia that he would not meet with Kissinger and his movement would have nothing to do with him. He accused the secretary of being "against our war of liberation" and said he can only be coming to Africa "to subvert and sabotage our liberation struggle."

Muzorewa's faction of the ANC is fighting an as yet small-scale guerrilla war against the white minority regime in Rhodesia.

The U.S. Embassy in Lusaka, the Zambian capital, called Bishop Muzorewa's statement "unfortunate and unconstructive" and said it "contains spurious allegations and serious distortions of United States policy."

While in Lusaka, Kissinger will deliver a major policy address, one of several he will make pledging U.S. economic aid, particularly to the tier of deprived states south of the Sahara, as well as political sup-

port. He once urged a go-slow policy on the black-white issue in a memo to former President Richard M. Nixon in 1970. But Kissinger now hopes to convince black Africans on the trip beginning this weekend that there is a new determination in Washington to see white supremacy ended.

In meetings with African leftist leaders, Kissinger also hopes to blunt advances by the Soviet Union and Cuba, which made major inroads during the Angolan civil war and have gained footholds in Mozambique, Somalia, Congo (Brazzaville), Guinea and elsewhere.

Brooks Announces Labor Post Bid

By TOM BAINES
Reflector Staff Writer

Raleigh attorney John Brooks returned to Greenville, his hometown, this morning to announce that he will seek the Democratic nomination for Commissioner of Labor.

Brooks, who made a strong, but unsuccessful, bid for the labor post in the 1972 primary, made Greenville his campaign kick-off point and then left for other scheduled press conferences in Raleigh, Greensboro, Charlotte and Asheville.

The attorney told the gathering here that the Department of Labor needs to take a more active role in the economic development of the state, specifically in "creating safe, better-paying, and profitable jobs in North

Carolina."

"It is not enough to collect statistics, to subsidize unproductive traineeships programs and to randomly inspect working conditions in North Carolina," he commented.

Brooks said that in the last four years, "while the number of industrial jobs and the productivity of North Carolina workers has risen to the top ten in the nation, the average hourly industrial wage paid to North Carolina workers has fallen to last in the nation."

He promised "a coordinated development plan to attract new industry and modernize existing industry, to guarantee equal employment opportunities for all, to train workers for better

(Continued on page 3)



JOHN BROOKS

Jessie Rae Scott Here Today—Campaigning For N.C. Labor Office

By CAROL TYER
Reflector Staff Writer

Mrs. Jessie Rae Scott, candidate for N.C. Commissioner of Labor, campaigned here today.

"Half of the working force in North Carolina is made up of women," she said, "so why shouldn't the administrator of the Labor Department be a woman?"

"I've always loved being a part of state government," the former first lady of the state said. "And now that four of our five children are away from home in school, I feel I have the time to devote to it."

She said she and former governor Robert W. Scott live at Hawfield, in Alamance County, which is about an hour's drive from Raleigh, and that, if elected, she will probably commute to and from most of the time.

Mrs. Scott, if elected, would be the first woman ever to serve on the Council of State, unless some other woman also goes into office following this election.

"I'm not running as a women's candidate," she said, "but as one who wants to be a public servant of all the people. I know very well that there is nothing glamorous about leading the state's smallest department, the one that deals daily with such mundane things as boiler and elevator and ferris wheel inspections. But it's an area that serves and protects people and I want to be a part of it."

OSHA, the 4,002 safety rules that the federal government has made and asked the states to enforce and administer, now takes up one-third of the time and effort of the N.C. Labor

Department, she said. "Within the next year, the entire job will be turned over to the state, we understand, and then it will take two-thirds. I am anxious to get in there and learn just how much good these occupational safety rules are doing the people and how much the state can do to make them less burdensome to employers and employees alike," she said.

She also said she would like to see "more satisfaction among all the parties involved in the apprenticeship programs administered through the Department of Labor."

Mrs. Scott is a former working girl herself, having worked over the years in a textile mill, food service, as a secretary, for the Internal Revenue Service, and as a teacher of English and

(Continued on page 3)



JESSIE RAE SCOTT

Sees Conspiracy

ROCKINGHAM, N.C. (AP) — R. B. Williams has accused fellow members of the Richmond County Board of Commissioners of conspiring to cover up illegal tax breaks. He says they granted the breaks to several businesses, including one owned by Sheriff R.W. Goodman.

Commissioner Williams made his accusations in a statement he read at a meeting of the board Monday night.

The chief targets of his criticism, Goodman and Commissioner D.L. McDonald, denied any improper activities.

Williams said in his statement that Commissioner Palmer Nicholson came to him last Dec. 1 and told him that "Goodman wanted a little help on some back taxes on Monroe Combining Co."

He added that Nicholson told him the commissioners wanted to release the firm from paying back taxes.

Williams said he replied that the valuation of the property had been cut \$70,000, and that it would be illegal to wipe out the back taxes.

Mid-East EMS Council Names New Chairman

Williamston — The Mid-East Commission's Emergency Medical Services Council met here last night in a re-organizational session and elected Terry Barber of Route 1, Jamesville, as chairman for the coming year.

Barber replaces Stuart Savage of Greenville, who has served as chairman since the EMS council was organized two years ago. In addition to Barber, an

employee of the Williamston Rescue Squad, Norma Faye Lewis of Greenville was elected as chairman of the council. Ms. Lewis is a registered nurse at Pitt Memorial Hospital.

The purpose of the EMS council is to conduct longrange planning and implementation programs to improve emergency medical services in the five-county Mid-East region — State Planning Region Q.

In the past, through state grants and local matching funds, the council has purchased radio equipment to the rescue squads and area hospitals together in a common communications network. Currently the EMS group has applied for a state grant that, if funded, will provide equipment for rescue squads and ambulance services in the Pitt-Martin-Beaufort-Bertie-Hertford county region to bring emergency vehicles up to

1976 standards.

Persons from Pitt County serving on the 27-member EMS Council include Ms. Lewis, Pitt County Fire Marshall Bobby Joyner, Mrs. Della P. Dayson of Greenville; Ronald Thiele, Dean of the School of Allied Health and Social Professions at East Carolina University; Gritton Rescue Squad member Raymond Eubanks; and Savage, a member of the Greenville Rescue Squad.

Roy Hardee of Greenville, Vice-President for News at WITN-TV in Washington is also a member of the council, appointed by the Beaufort County Board of Commissioners as a representative of Beaufort County.

Among other members of the council are: Gene Alligood, Beaufort County Civil Preparedness director; Col. Dave Spivey, Area "A" Civil Preparedness Director

from Washington; Dr. Albert Daw of Washington; Phillip N. Waters, Bertie County Civil Preparedness coordinator; Ms. Rodanthe "Pete" Hall, chief of nursing at Bertie County Memorial Hospital; Mike Roberson of the Robersonville Rescue Squad; Warren Goff, assistant administrator of Martin General Hospital in Williamston; Lester Harrell Jr. of Oak City; and Paul Barber of Route 1, Jamesville.

REFLECTOR HOTLINE



752-1336



Hotline gets things done for you. Call 752-1336 and tell your problem or your sound-off or mail it to Hotline, The Daily Reflector, Box 1967, Greenville, N.C. 27834.

Because of the large numbers received, Hotline can answer and publish only those items considered most pertinent to our readers. Names must be given, but only initials will be used. Transcribing is done once a day.

APPRENTICESHIP FOR GIRL?

Do you know of any funeral home in Eastern North Carolina that would hire a woman to serve an apprenticeship? D.W.

Lindsay Wilkerson of the Wilkerson Funeral Home here said, "I know there are women truck drivers now, but nevertheless, it's my feeling that I would not like to ask a woman to do all the difficult jobs that our apprentices must handle. There's heavy lifting, there are crazy hours, there are out-of-the-way places to go, there are all kinds of conditions to be weathered. We have never considered accepting a woman as an apprentice, though we've had a number of female applicants. All funeral directors may not feel as I do, though. I guess it would really be up to this young lady to check around on her own."

North Carolina requires both certification from a school of mortuary science and an apprenticeship, he said.

He gave us the name of three schools you might like to contact about their programs. These are Cincinnati College of Embalming in Cincinnati, Ohio; Gupton-Jones College of Embalming in Atlanta, Ga.; and Dallas Institute of Mortuary Science in Dallas, Tex.

No Judicial Robes For Her--It's Jeans, T-Shirt

By MELANIE JONES
Birmingham News
RAINSVILLE, Ala. (AP) — While Petrocelli is only a television series of a cocky lawyer in a small town, North Alabama has the real thing. Rainsville's own Judge Terry Tumlin Bush could be known as the female counterpart.

A 1972 graduate of the University of Alabama School of Law, the spunky blonde has been in practice for two years. At 26, she is already the municipal judge for Fyffe, Dutton, Pisgah and Section, the city attorney for Rainsville's 2,000 residents, and one of two attorneys for DeKalb County.

She also maintains a law office in Rainsville. Looking like a college student in her second-hand earth shoes, blue jeans and T-shirt, the outspoken woman admits she has a hard time convincing some people that she's an attorney.

"I guess people stereotype a female lawyer as a gray-haired woman who wears her hair in a bun." Pointing to her long, straight hair she added, "I tried that but my hair kept falling out. The reason I wear jeans is because I don't know when I'll have to go to a cow pasture to see a client's dead cows."

Recalling her first case, a divorce suit, Terry related, "I went with my client to the courthouse to file for divorce and the other attorney was there so the judge decided to go ahead and have the hearing.

"Well, there I was in blue jeans, a T-shirt with no bra, wearing penny loafers without socks. And there was the other lawyer with his three-piece suit and diamond stick pin.

Leaning back confidently in the swivel chair in her office, she said, "I think the judge figured if I had the guts to come to court like that, I ought to win."

The blue-eyed judge said she's used to getting second looks from clients unfamiliar with her. "I've seen some people come in my office and just stare. I see no relevance in this but the first thing they ask is, 'How old are you?'"

"I can go to court in another county where they don't know me and there's always some-



TERRY TURLIN BUSH

body who says, 'Can I help you, little girl?'"

Despite the problems of first impressions, Terry said it helped to be a woman attorney more than it hurt.

"It may be because I grew up in Fyffe, but I get along with everybody. Back in school, people would tell us to prepare to starve for the first two years of practice. But that hasn't happened yet."

She said most of her clients tended to know her because of her parents or grandparents. The problem comes in when people try to contact her after office hours.

"They call all my relatives if they can't find me. Sometimes they call my house and get my husband, Chris. He drives a truck, you know, but people assume since I'm a lawyer, he knows all about these things. So they tell him all about their case."

In what Terry describes as the "strangest marriage in the state," she said she has tried to persuade Chris to join the Bar Association Auxiliary made up

Secretaries Chapter Holds Luncheon

Seventy-four members of the Greenville Chapter of the National Secretaries Association International and their bosses and invited guest held a luncheon with a bicentennial theme at the Greenville Golf and Country Club yesterday.

Speaker for the occasion was Reece B. Gardner, industrial and commercial contractor of Kinston. He was introduced by Betty Thompson. Becky Riley was mistress of ceremonies, and Mary Doyle gave the invocation.

Yvonne Hardee, 1975 Secretary of the Year, presented the 1976 Secretary of the Year certificate to Becky Riley, who was honored earlier this year.

The Outstanding member of the Year award was given to Brenda Gipson, secretary to W. R. Brannigan of Burroughs Wellcome Company, by Brenda Wilson, Outstanding Member of 1975. Mrs. Gipson was presented an engraved plaque recognizing her "outstanding contributions to the chapter during the past year."

The Past President's Pin was presented to Yvonne Hardee by Brenda Wilson. Ellen Webb led the members in reciting the Code of Ethics.

This year's officers are Yvonne Hardee, president; Brenda Wilson, vice president; Marjorie Davis, recording secretary; Myrtle McRoy, corresponding secretary; Betty Andrews, treasurer; and Karren Averette, Amy Mills, and Betty Thompson, directors.



Brenda Gipson

Couple Speaks Vows Saturday

Miss Catherine Weaver, daughter of Mr. and Mrs. Charlie Mack Weaver of Greenville, became the bride of Elmo Rosario Saturday afternoon at three o'clock at the home of her parents.

The bride was given in marriage by her father.

The ceremony was performed by the Rev. Kenneth Hammond. A program of wedding music was presented by Miss Judy Gay, cousin of the bride.

Following the wedding a reception was held in the yard, given by the parents of the bride.

After a wedding trip to unannounced points, the couple will reside in Jersey City, N. J.

weekend here with his parents, Greenville.

Mr. and Mrs. Steve Jefferson and children, enroute to their home in Davidstown, Pa. from Atlantic Beach, visited here with Miss Hazel Patrick.

Miss Olivia Reeves is spending this week in Wilmington with friends.

Miss Mana Patrick is recuperating at her home here after being a patient at Lenoir Memorial Hospital, Kinston.

Mr. and Mrs. Ron Anderson of Morehead City and Mrs. Pauline Anderson of Alva, Oklahoma were Easter visitors here.

Mrs. John Barwick, Miss Mary Glenn and Sam Barwick of San Pedro Sula, Honduras arrived during the weekend for a visit with Mrs. Sam Barwick and other relatives. They will be joined later by Mr. Barwick.

Mr. and Mrs. Robert Oglesby and sons, Bobbie and Ryan, of Kernersville spent the weekend here as guests of Mr. and Mrs. J. T. Oblesby.

Patrick Oglesby has returned to Chapel Hill after spending a

At Wit's End

By Erma Bombeck



"Hey Mom," said my son the other afternoon. "Why don't you talk to this guy at the door?"

"What does he want?"

"He's selling firewood."

"Winter's over. We don't want any."

He hesitated. "Just talk to him. He's so old and he looks sorta shabby and I think he needs the money."

On the way to the door, I got a mental picture of Willy Loman from "Death of a Salesman," with red-rimmed watery eyes, graying hair, pants in need of pressing and shoes with the heels run down.

I opened the door. There stood a guy about 28 years old in faded jeans and a \$40 McGregor windbreaker. He was checking his digital watch for the time. His 1975 Ford truck stood in the driveway.

"What's with the old and shabby number?" I said later to my son. "That guy couldn't have been more than 28 or 29 years old."

"That's middle age," he said. The dictionary lists middle age as somewhere between youth and old age. I'd pinpoint it somewhere between birth and death. It fluctuates depending on your own age.

When I was 17 and a senior in high school I had a teacher who was seven years older than I. At 24, he was middle-aged and more's the pity, he didn't know anything. I hung around after class because I felt sorry for him.

When he was 31, I was 24. My husband and I saw him at a

dance one night and he looked bored. Why shouldn't he have looked bored? His life was over. His body was gone. He had advanced as far professionally as he was going to go. And I was sure he never kissed his wife. I mean, what for?

When he was 38, he was 10 years older than I and looked it. He wore the coat sweaters and was showing some signs of gray. Sometimes though, when he hallucinated, he made some pretty good sense.

Years later, when he was 45, he was 13 years older than I and I had to marvel at how well he was holding up. He told me he and his wife were doing some traveling and he still remembered my name.

I saw my old teacher the other day. I figured out he was 56 years old now.

"My goodness," he said, "that would make you 49 and middle-aged, wouldn't it?"

The poor devil is so squirrely. I'll never understand why they let these old, confused people climb behind the wheel of a car. Everyone knows middle age is 10 years from wherever you are and the way I'm going, I may never get there.

Fresh Rolls
Diener's Bakery
815 Dickinson Ave.

Susan's

SPRING CLEARANCE SALE

Selected Group
Dresses..... 25 To 50% off

Group Famous Brand
Sportswear..... 25% off

Pantsuits..... 1/3 off

Group of
Sportswear..... Savings Up To 50%

331 Arlington Blvd.

Grifton News

Mrs. Walter Pittman has returned from a recent trip to Miami, Fla., where she visited her daughter, Mrs. Bob Collins, Mr. Collins and children.

H. C. Oglesby is a surgical patient at Pitt Memorial Hospital, Greenville.

Mrs. Mary McLawhorn, Mrs. Sallie Smith, Mrs. Lucy Wright of Goldsboro and Mrs. Allie P. Todd of Kinston were guests during the weekend of Mrs. Beatrice Maynard.

Mrs. Robert Mewborn, Miss Louise Mewborn and Tom Mewborn were in Whiteville Sunday for the Cooper family reunion.

Mr. and Mrs. G. L. Tucker visited during the weekend in Star with Miss Donnie Stout.

Mr. Tom Gower spent the weekend in Charlotte with Mr. and Mrs. Walter Scholtz. He was accompanied home by Mrs. Gower, who had been there for the past week.

Mr. and Mrs. Donald Stancill and son, Gene, have returned from a trip to Suffolk, Va., where they accompanied Mrs. Mazie

Stancill, who will visit in the home of Mr. and Mrs. Herman Stancill for several days.

Mr. and Mrs. Joe Hart of Chapel Hill spent the weekend here as guests of his mother, Mrs. J. M. Hart.

Mr. and Mrs. Paul Bradley have returned from an Easter visit in Atlanta, Ga., with their daughter, Miss Paula Bradley.

Mr. and Mrs. John LaCava and children, Sallie, Pam, Laura, Beth and David have returned to their home in Woodbridge, Va., after an Easter visit here with Mrs. L. L. Mewborn.

Mrs. John Barwick, Miss Mary Glenn and Sam Barwick of San Pedro Sula, Honduras arrived during the weekend for a visit with Mrs. Sam Barwick and other relatives. They will be joined later by Mr. Barwick.

Mr. and Mrs. Robert Oglesby and sons, Bobbie and Ryan, of Kernersville spent the weekend here as guests of Mr. and Mrs. J. T. Oblesby.

Patrick Oglesby has returned to Chapel Hill after spending a

James Kenrob

James Kenrob designs summer fashions to reflect your inner moods. Like this fluid boucle sweater dress that meets romantically in two parts... cabled scoop neck top and gored skirt. Sizes 6 to 18, \$75. A division of Dalton

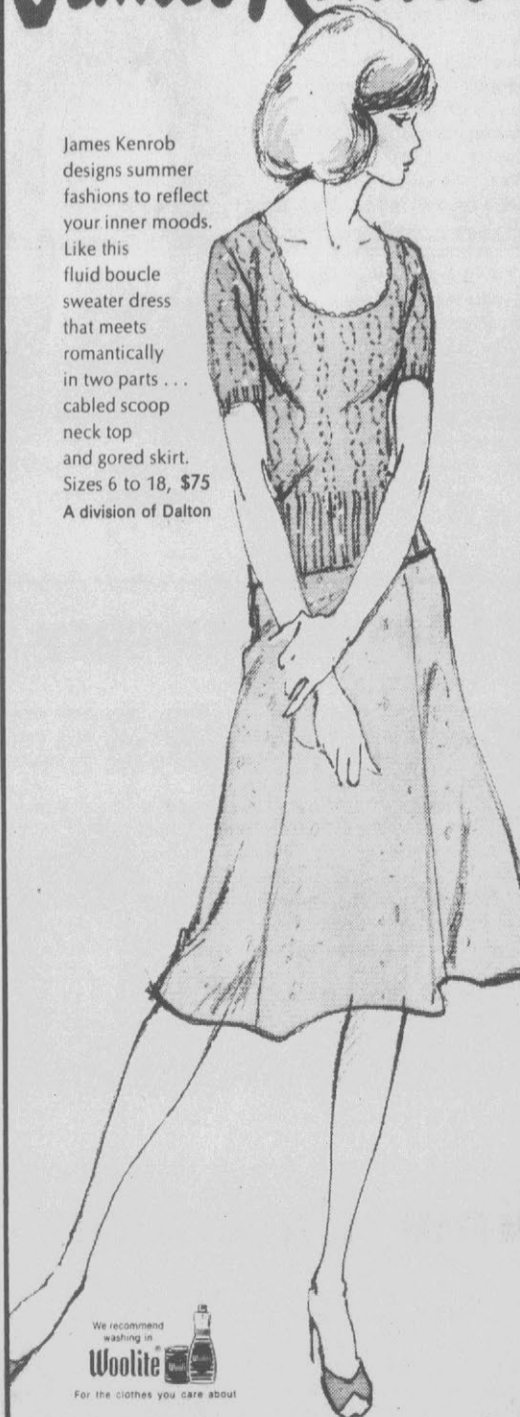

Blount-Harvey

Shop Daily 10 A.M. to 5:30 P.M.
"Home Owned & Operated For 55 Years"

Experience
America's most
comfortable
shoe*

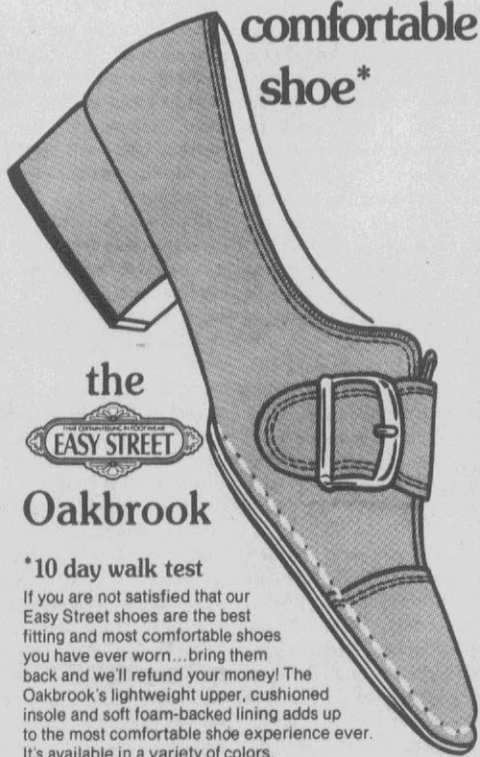

the
EASY STREET
Oakbrook

*10 day walk test

If you are not satisfied that our Easy Street shoes are the best fitting and most comfortable shoes you have ever worn... bring them back and we'll refund your money! The Oakbrook's lightweight upper, cushioned insole and soft foam-backed lining adds up to the most comfortable shoe experience ever. It's available in a variety of colors.



Pastels, Red-White-Blue, Bone, Black, Navy, Tan.

Friday & Saturday Only **\$13.90**

Blount-Harvey

"Home Owned & Operated For Over 55 Years"
Shop Daily 10 A.M. - 5:30 P.M.

Brody's
DOWNTOWN
PITT PLAZA

Swim Bali

Swimsuits That Match Your Top And Bottom,
Even When Your Top And Bottom Don't Match.

Our two-piece swimsuit comes in both your sizes. And the place to find them is in the swimwear department. Just pick the top in your bra size and get the perfect fit of a Bali bra. Then pick out the bottom in your hip size for a top and bottom that fit like they were made for you. Sizes 32 to 38, A - DD cups.

Tops \$13 to \$15
Bottoms From \$10



Brody's
DOWNTOWN
PITT PLAZA

Jessie Rae...

(Continued from page 1)
business education. She is a graduate of the University of North Carolina at Greensboro, where she earned a B.S. degree in business administration. She is active in the Hawfields Presbyterian Church and the American Cancer Society, and is treasurer of Scott Enterprises, Inc., her husband's family's business. Her children are Mar, Meg, Susan, Kerr, and Jan.

John Brooks...

(Continued from page 1)
jobs, and to insure safe and healthy conditions in the workplace."
Brooks said he would encourage the use of the new Industrial Development Bonds Authority to meet the needs of industry and its workers and he called for establishing an equal opportunity bureau in the Labor Department to give special attention to the needs of women, blacks, youth and senior citizens.

He observed that "we must seek to modernize existing industry in the state" and he called for a "vigorous program of vocational education in our community colleges and technical institutes as well as meaningful on-the-job training programs for workers wishing to improve their skills and to increase their paychecks."

Brooks told the press gathering that five goals he has for North Carolinians are: more jobs, higher-paying jobs, training for better jobs, equal job opportunities, and safe places to work.

Pointing to his training in economics and the law, Brooks said that new leadership must anticipate future problems and propose workable solutions to them.

Brooks polled some 46 per cent of the vote in the 1972 runoff primary.

A graduate of Greenville High Schools, the attorney earned his A.B. degree in political science from the University of North Carolina at Chapel Hill as a Morehead Scholar. He received his law degree from the University of Chicago School of Law.

In law practice in Raleigh since 1971, he served as administrative officer and director of legislative research of the 1969 session of the state General Assembly. Brooks is also a former law clerk to Chief Justice William H. Bobbit on the North Carolina Supreme Court.

Most Leaned To Land-Use Policies

By SUSAN QUINN
Reflector Staff Writer
The majority of the discussion concerning the N.C. Land Classification Policy was in favor of the policy at the Public Hearing held by the N.C. State Land Policy Council Wednesday night in Greenville.

Land Policy Council members and Land Policy Advisory members directed the public hearing. Members of the Land Policy Council present were Bruce Lentz, Secretary of the Department of Administration, chairman; Senator Willis Whichard and Griffon Mayor Dave Bosley. Land Advisory members included Jane Sharp, Dr. M. A. Ray, Frederick Cooper, and Bruton Pate. Bill Swindanson, a Land Policy staff member was also present.

The council members presented a slide show about the land use policy and how it could help coordinate efforts of all governments for the best possible land use.

The slide presentation explained that the classification system would divide the land into five areas. They are as follows: developed or urban areas, conservation or historical and environmental areas, rural and community areas.

Approximately 50 people attended the hearing, but only about four people made statements and only a few asked questions.

John Schofield, Greenville City Planner explained the city's interest in the policy in three points. Schofield said that the city is interested in (1) a coordinated system of all governments for developing a land policy.

"I feel that the policy is a step in the direction of working together with governments for

the best possible land use. (2) "The policy helps us look toward our neighbors and find out how we can share land use problems."

(3) "The policy is a step toward addressing major problems with property taxation and land development."

D. R. Taylor of Tarboro explained that he was concerned in reading the policy that "the state might preempt local government's decision in regulation of flood plain and historical areas."

"We think that the local control of the historical areas is a good policy and we do not want to see this local control taken away."

In answer to Taylor, Senator Whichard explained that for federal funding purposes, historical areas which are designated as an environmental area must be controlled by a state committee which can be made up of local members.

Patricia Daugherty representing the Pitt County

League of Women Voters explained that the league had carefully considered the land policy and has found two problems. (1) Insuring public participation and (2) The coordination of local agencies whose activities affect land use.

"We believe that it holds a sound basis for better growth of the state," she said.

W. D. Lewis, Wilson County Agricultural Extension Agent commended the council for its research and planning.

"I am particularly pleased with the consideration given the agriculture. I hope that the council will explain that the rural areas must realize that if agriculture is there it must be permitted to operate as an industry."

A few questions were entertained by the council members and the council urged those persons present who did not make a verbal statement to send a written statement to the Land Policy Council at its Raleigh office at 116 West Jones St.

VFW Honors Supervisor

ELIZABETH CITY—John W. "Bill" Ervin, Area Supervisor for the Employment Security Commission, was recognized by the North Carolina Department of the Veterans of Foreign Wars (VFW) and received their National Employment Award in a ceremony last Sunday.

The citation, sponsored by the VFW's Civil Service and Employment Committee, commends Ervin for outstanding service to veterans in the nine Job Service offices in his administrative area during 1975.

On hand for the afternoon presentation at VFW Post No. 4060 here were Ed Bass, Chairman of the Governor's Jobs for Veterans Committee, and Lawrence A. Britt, Assistant State Veterans' Employment Representatives, U.S. Dept. of Labor.

During 1975, ESC offices under Ervin's jurisdiction processed 7,276 new and renewed job applications from veterans, and placed 1,891 in jobs; 335 of which were handicapped veterans. During the same period, the officers enrolled 158 veterans in training programs of various types.

Ervin is a Navy veteran of the Korean War, having served from 1950 to 1954.

Cancer Soc. Hears Cain

Bill Cain, director of athletics at ECU and 1976 vice-chairman for Area V of the N. C. Division of the American Cancer Society, addressed volunteers for the 1976 Cancer Crusade last night.

"Each of you here tonight has had his own experience with cancer," Cain said. "Cancer killed 114 in Pitt County last year and statistics say cancer will strike two out of three families now living."

He expressed his appreciation to all volunteers and urged them to work toward the goal of \$15,000.

The workers will be canvassing from now until mid-May. Additional volunteers are needed in some areas. Anyone who would like to help distribute leaflets and ask for contributions should contact the unit office at 756-7858 or Charles M. Vincent, Crusade chairman.

Home Care Needs **Sales Or Rentals**

Why Pay Retail For Medical Supplies

Come see us, we are a wholesaler of Medical Supplies (Except Drugs), selling to the public as well.

752-4757

Southern Hospital Supply Co.

10th St. Opposite Sherwin Williams Greenville

Belk Tyler

FOUNDER'S DAYS SALE

SALE! SAVE ON LADIES' 100% POLYESTER DRESSES 18.88 To 30.88

Regular 28.00 To 46.00

Fashionable silhouettes for spring and summer in printed spring pastels. In easy-care 100 per cent polyester. Sizes 10 to 20. Hurry in for the savings and selection.

SAVE 7.12 NOW ON GROUP OF JUNIOR POLYESTER SLACKS 10.88

Regular 18.00

Famous maker slacks in 100 per cent woven polyester surline. Perfect fitting high waisted and belted models. In summer pastels and navy. 5 - 15.

SALE! LADIES' CULOTTES 13.88

Regular 16.00

Dacron-cotton blended. Sleeveless one piece culottes. Zipper crotch. 8 - 18.

SALE! JR. TUBE TOPS 1.77

Regular 3.00

Elasticized Dacron-cotton tops. In prints on light backgrounds. One size fits all.

SALE! LADIES' EARRINGS 99¢

Regular 3.00 & 4.00

Gold or silver pierced or clip on styling. Large selection. Hurry and save!

SALE! LADIES' HOUSECOATS 8.88

Regular 11.00 & 12.00

Gripper front, open point collar, short cuffed sleeves and patch pocket. In prints. Sizes S, M, L.

SALE! LADIES' SLEEPWEAR 5.88 & 6.88

Regular 7.00 & 8.00

Nylon tricot sleeveless shift gown. Scalloped edge daisy embroidery on shaped yoke. Sizes S, M, L.

SHOP THURSDAY AND FRIDAY 10 A.M. TIL 9 P.M. SATURDAY 10 TIL 6

for your convenience... **charge it**

Belk Tyler

Big Savings During Our Founder's Days Sale

'Andhurst' texturized polyester suits 69.88

usually \$100-\$110

The 'investment' suit that can take you anywhere, and with style. Two-button, slightly accented shoulders, center vent. Smart solidness with stitched accents; fancy weaves. Regulars to longs.

You will be pleased with the wide selection of pastel shades in solids and plaids. See these tomorrow for sure.

for your convenience... **charge it**

In Downtown Greenville

SALE! SAVE ON MEN'S WEYENBERG SHOES 27.88

Regular 32.00 To 36.00

First quality shoes with long wearing comfortable fit. Brown or black leather upper. Sizes 8 - 11, C, D, E Widths.

SALE NOW ON WILSON TENNIS BALLS 2.44 Can

3.25 Value

Championship extra duty, optical yellow balls. Limit 2 cans per customer.

SALE! CORNING SPICE 'O LIFE SAUCEPAN TRIOS 12.88

Special Purchase

Set consists of 1, 1 1/2, 2 quart saucepans. Glass covers for each pan and 2 plastic lids.

SALE! SAVE ON MEN'S POLYESTER SUITS 38.00

Regular 50.00

100 percent polyester in solids and fancies. 2-button, wide-lapel styling. 38 - 46.

SALE! MEN'S AND BOY'S DUCK TENNIS SHOES 3.49

Regular 6.00

100 per cent cotton duck. Low cut styling. In white, light blue, navy and black. 12 1/2 - 3, 3 1/2 - 7, 6 1/2 - 11.

SALE! TRIPOD BAR-B-QUE CHARCOAL GRILL 7.88

Regular 9.99

Removable, straight tripod legs. New positive grid adjustment. Hardwood handles. Chrome-plated grid.

Season To Talk Water Safety

Five persons drowned over the long Easter weekend in North Carolina and that's too many. We can expect more such grim reports as spring moves into summer and the warm days turn more and more multitudes to recreation on or near the water.

The great need is for awareness of water safety, and all that entails. Of equal importance in some knowledge of how to swim.

Swimming skills do not have to be developed to Olympic levels in order to enjoy the water in safety. A parent can devote a few minutes or an hour for maybe ten days, and a child can paddle. It's worth the bit of inconvenience. Lessons are available from any number of trained instructors all over eastern

North Carolina.

Water safety is something for both adults and children to know. Basically it involves acquiring a healthy respect for eventualities to be avoided . . . and then living by that respect so the example is comprehended and imitated.

There are always going to be drownings, but there need not be watery deaths due to inability to swim ten feet, or stay afloat, or due to plain stupidity.

This is a good time of year to think about the coming months to be enjoyed by all the family . . . and to prepare for it. To do less is to invite tragedy beyond measure.

Texas Would Be Important For Reagan

The next big test of the Republican presidential race will come in Texas on May 1.

Former Gov. John Connally says he will remain neutral in the race but earlier this week he speculated that Ronald Reagan is ahead in the Texas race. However, Connally said, the vote could

swing either way, and if ten percent of the voters changed their minds it could affect the outcome.

Ronald Reagan has an uphill battle for the GOP nomination, but a Texas win would be important to him. A loss probably would be fatal.

THIS AFTERNOON

Ombudsman Being Ousted

By BILL NOBLITT
RALEIGH — The state's experimental nursing home ombudsman is being forced out of his job, and there are some signs the action results from some unhappy nursing home operators.

Despite the strongest endorsement from his supervisor and expressions of support and interest from several legislators, Vince LoMonte faces a firing this month.

The official reason is that he cannot successfully pass a test to qualify for an Administrative Assistant III. But his boss, Robert Q. Beard, executive director of the office for aging in the Department of Human Resources, rejects that as a legitimate beef.

He has told several key lawmakers, and top officials in both the Department of Human Resources and the Department of Administration, that LoMonte should be kept on board.

Job Defended
In a letter to his bosses, Beard said bluntly that he has "requested that it (the job title) be changed to a more

appropriate classification, since an ombudsman function bears little resemblance to that of an administrative assistant."

An administrative aide handles paperwork, staff supervision, and office work. An ombudsman is a go-between for the public and the bureaucracy, to hear complaints, investigate them, and try to iron out problems for citizens faced with the complexities of a given system.

"The fact that Mr. LoMonte has been functioning effectively as an ombudsman for five months, but so far after two tries is unable to pass the written test for Administrative Assistant III, indicates the inappropriateness of the present classification," Beard informed top state officials. He also feels that trying to break in a replacement would prove difficult in the short time remaining in the federal ombudsman grant program.

Nonetheless, administration officials are standing by the decision of J. P. Johnson, director of the state's Raleigh personnel office: "Personnel regulation requires that he be

separated from employment no later than April 22 . . ."

LoMonte, Beard, and others are convinced the pressure on LoMonte comes from disgruntled nursing home operators. Prior to establishment of the ombudsman office, nursing homes were inspected only by an agency of the Department of Human Resources which regularly notified the homes of an inspection visit as much as 30 days ahead of time.

State Senator Harold Hardison, D-Lenoir, is backing LoMonte. "He is doing the job that needed doing . . . he has obviously hit a nerve."

Some Complaints

Of the state's 164 nursing homes, the bulk are doing a fine job. LoMonte says. But problems have been experienced with about 30 of them, and it is those, he feels, who are bringing pressure.

LoMonte regularly visits unannounced, checks into a local motel, interviews nurses and employees, the relatives of patients in the homes, and finally pays a surprise visit.

He can provide graphic

accounts of mistreatment which he has encountered firsthand, and has also been involved in several negotiations to recover money which operators might be holding unlawfully.

"I'm slowly, little by little, cracking through the shell. People across the state are finding out there is somebody they can trust to represent them . . . somebody wants to help," LoMonte says.

And that, Hardison and State Senator Carl Totherow, D-Forsyth, believe is the problem.

"We do have a problem with some nursing homes. Perhaps we need an independent state investigative staff . . . we don't need to cut this out, we need to expand it," Totherow thinks.

LoMonte, a former television newsman, was hired by former Human Resources Secretary David T. Flaherty who resigned earlier this month to run for governor in the Republican primary.

LoMonte says he knows that some nursing homes have complained to top state officials about him. "I think they have got to somebody."

SOMETHING TO REMEMBER!

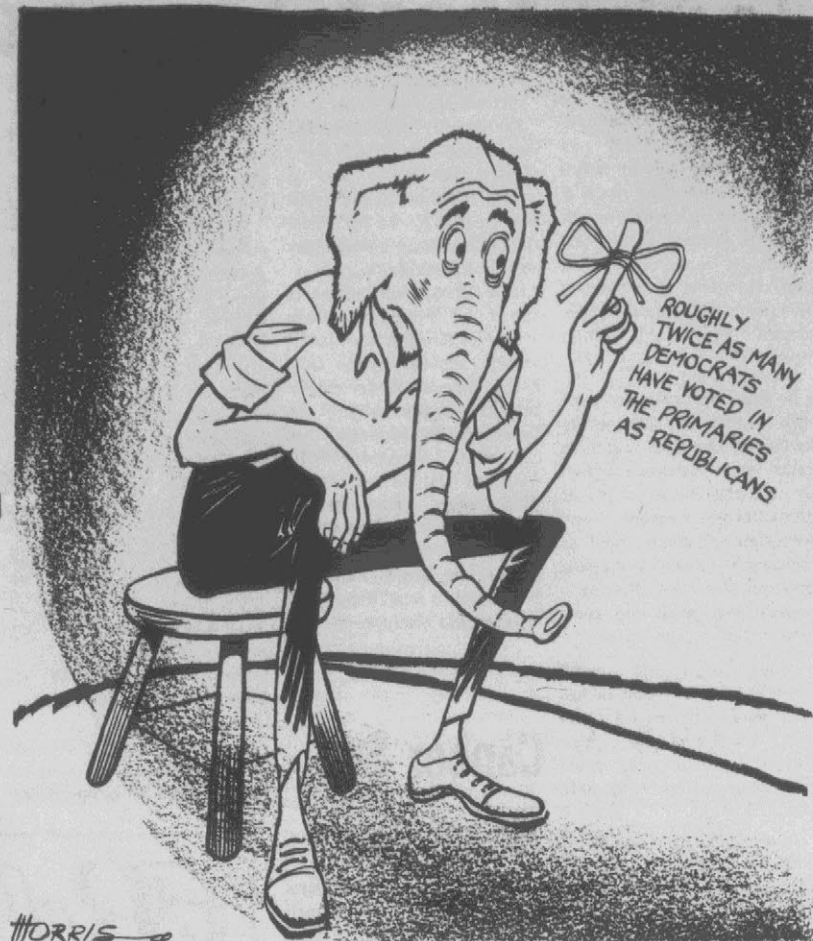

MORRIS

By ART BUCHWALD

He Took It With Him

WASHINGTON—There is an old saying, "You can't take it with you," meaning that when you go, you have to leave your worldly goods behind. But now there is a rumor going around that Howard Hughes took it with him. I got the story from a very reliable source—Clifford Irving.

When Howard Hughes knew the end was coming, he

called in his lawyers and said, "I don't want to leave anything behind. I want to take everything I own with me."

The lawyers were agog. "But you can't, Mr. Hughes. It's illegal."

"Don't tell me it's illegal or I'll get another team of lawyers. Work it out some way. I built up this fortune from scratch, and I'll be

damned if anyone is going to get it after I'm gone."

"Yes, sir. You're talking about the Hughes Aircraft Co., the Las Vegas hotels, Hughes Air West and all your land interests."

"Everything, including my silver mines in Nevada. I want it all."

One of the lawyers said, "I'll check it out, Mr. Hughes. I don't think IRS can do anything about it if you take it with you since they can't get their hands on it. But as I see it, the problem is really one of transportation. That's an awful lot of stuff to take with you. You might have a much better chance if you sell everything and take the cash."

"I don't want cash. I want all my properties. Cash may not do me any good where I'm going."

Another lawyer said, "But you could have a customs problem at the other end. They might make you pay 50 percent on everything you bring in."

"Get to the customs people some way so I don't have the problem."

"We don't know who the customs people are, Mr. Hughes. We've never dealt with them before."

"Well, find somebody who has. That's what you're paid for."

"Yes, sir, we'll get to whoever is in charge. There's one matter, though. I don't think there will be any objection to taking the satellite and helicopter companies with you or even the oil drills. But there could be some question about the seven gambling casinos you own. I'm not certain of this, but gambling may be illegal where you're going."

"Then find somebody to make it legal. I have a lot invested in those casinos and a sentimental attachment to them."

"But, sir, if you take the gambling casinos with you,

Revolt On Tax Change

By MICHAEL GOLDSMITH
Associated Press Writer
PARIS (AP) — France's powerful middle class, which has made and unmade many a government since the fall of the Bastille, is in revolt against President Valery Giscard d'Estaing for proposing the first capital gains tax in French history.

France is one of the last countries in Western Europe without any kind of tax on investment profit other than income tax on interest payments. The United States levies a capital gains tax against half the profit from the resale of real estate, stocks, art objects and other investments held six months or longer.

Giscard, who was elected two years ago with wide middle class support, introduced the new tax legislation after pressure from Communists, Socialists and the left wing of his own coalition. He said it was intended mainly to tax the profits of speculators.

The proposed law pleased none of the major political parties, and there is almost no chance of its being adopted in the present form.

The president, apparently unprepared for the hostile response, tried to cover his embarrassment by promising the National Assembly full freedom to amend the bill when it comes up for parliamentary debate late next month.

But the dispute constitutes another serious loss of face for Giscard — whose term ends in 1981 — following sweeping setbacks in local elections and several opinion polls that also indicate that the Socialist-Communist opposition alliance has gained significant strength.

Critics of the proposed new tax say it would hit some 300,000 small savers and investors, would leave the profits of big-time speculators virtually untouched and would increase government revenues less than a third of one per cent.

As proposed, the tax would be applied to any personal profit of more than \$642 obtained by the resale of stock, gold, real or art objects within 40

(Continued on page 5)

IT'S YOUR MONEY

Legal Trick For Interest

By DAVID R. NELSEN
Associated Press Writer
Even though it's illegal for banks to pay interest on checking accounts and savings and loan companies cannot offer that type of account, some S&Ls are offering 5 1/2 per cent daily interest on money in your checking account.

The trick—and it's legal—is called telephone transfer. By signing a contract, the customer gives his S&L access to bank checking account. The customer keeps only enough in his checking account to qualify for free checking if a minimum deposit is required. The rest of the money is in the S&L earning interest.

Suppose the customer paid \$250 rent April 1 and he gets his paycheck on the 15th of each month. The \$250 budgeted for rent could be in the S&L earning interest from March 15 to April 1 when the customer would call a special number and tell the S&L to put \$250 in his bank

checking account. If the call is placed before 1 p. m., the transfer will be made that day. Transactions after 1 p. m. are considered by bankers as taking place the next day.

It's troublesome and costly for S&Ls to provide the service because an employee must go to each bank as ordered by the customers. But, it becomes worthwhile if the S&L can put the money to work and earn more than 5 1/2 per cent interest.

Telephone transfer is the latest wrinkle in the continuing competition for control of money in checking accounts. The struggle was once between banks which offered free checking and used other gimmicks to lure customers.

It costs a bank an average of 13 cents per check to offer checking accounts. Bankers say they offer free checking for two reasons: it increases the number of customers who may use other bank services such as credit cards and

loans; and they use the money to make money on short term investments such as bonds and loans. Some banks set a minimum balance for free checking just so they can be sure of having some money to invest from each checking account.

Large banks have millions of dollars on deposit in personal and business checking accounts. Being forbidden by law to pay interest, the banks have free use of money in those accounts.

Amounts on deposit in checking accounts can fluctuate, though. It sometimes will happen that a bank will begin a day loaning money to other banks and by that afternoon borrow to cover withdrawals by its customers.

Because of the large sums involved, the potential for profit is great even if the percentage earned is small. That potential is what drew S&Ls into the competition.

"It's expensive," said Judy Wilcox of Carolina Federal S&L in Raleigh. "But, as long as we can reinvest it at something more than 5 1/2 per cent, we can make money on it."

Like the minimum deposit on checking accounts, some S&Ls require a minimum savings deposit. First Federal in Raleigh requires

\$500 because the company wants to be sure its costs are covered, said Tom Miller, a First Federal vice president. The minimum could be changed when the firm determines cost of the service, Miller said.

Business accounts, commonly with hundreds of thousands of dollars on deposit, are the most actively sought for the telephone transfer accounts, Ms. Wilcox said. If a business has \$100,000 on deposit it can earn \$43.33 interest in three days at 5 1/2 per cent. In a year it totals \$5,389.85.

"We're not trying to raid the banks," Miller said, noting, "We realize they would not be too pleased" if the system is widely accepted.

There's nothing bankers can do to prevent it. John F. McNair III, executive vice president of Wachovia Bank and Trust, said it would alienate customers if bankers made it difficult for S&Ls to transfer money under the system.

Winton Poole, senior vice president of North Carolina National Bank, said NCNB hasn't taken a stand because the system hasn't presented itself as a threat. A telephone transfer system in the Greensboro area failed, he said, because "the public just

(Continued on page 5)

Strength For Today

HIDDEN IDOLS
Many years ago missionaries among South American Indians persuaded their converts to build a beautiful church. But the Indians were determined not to give up those idols which their ancestors had been worshipping over the centuries. They built the church according to specifications, but secretly they placed these idols between the inner and outer walls.

And so as centuries have passed, these Indians have knelt in the church, ostensibly Christian worshippers, but from father to children the information has been handed down as to just where the old Indian idols were placed between the walls. They kneel and pray to Christ and the saints, but secretly they also give their obeisances to the idols of their ancestors.

How many of us follow the same procedure? On the surface we are solid Christians, but many of us worship secret idols of wealth, power, or self-indulgence.

Many clubs during the past year have outperformed the returns obtained by professional portfolio managers. In the 14 or 15 months ending with December 1974, one club reported its value increased 212 per cent.

Thomas O'Hara, chairman of the National Association of Investment Clubs, reports inquiries on the rise again, suggesting strongly that the number of member clubs soon will rise above the current recession-induced total of 7,000.

—by Elisha Douglass

Investment Club Interest Rises

By JOHN CUNIFF
AP Business Analyst
NEW YORK (AP) — Interest in stock investment clubs is rising again after declining sharply during the dark days of the economy. Planning for the future, rather than merely securing the present, looks attractive again.

Also spurring interest is the quick recovery of some clubs that continued to invest during the big price decline of 1973 and 1974, and which thus picked up blue chip shares at tarnished goods prices.

Many clubs during the past year have outperformed the returns obtained by professional portfolio managers. In the 14 or 15 months ending with December 1974, one club reported its value increased 212 per cent.

Thomas O'Hara, chairman of the National Association of Investment Clubs, reports inquiries on the rise again, suggesting strongly that the number of member clubs soon will rise above the current recession-induced total of 7,000.

The clubs, which in effect are small, private mutual funds that are managed as well as owned by the members, generally involve about 12 people of similar goals, although often of dissimilar but complementary skills.

The clubs permit members to learn about investing, to invest small amounts at a time, to spread the risk through diversification, to compare investment research and, if they do well, to see their assets grow.

Their importance seems to have been underscored by the recent decision of the New York Stock Exchange to discontinue sponsorship of the Monthly Investment Plan, which permitted small investors to buy even fractions of shares.

Merrill Lynch continues to operate its Sharebuilder Plan, which is similar, but other brokers seem to have lost interest in — and it is claimed, money on — small accounts.

Clubs fill this gap. Although their purchases may be in round lots of 100 shares or more, the individual mem-

bers' percentage of the total often is an amount that most brokers wouldn't consider handling.

Generally a club has informal beginnings among a few friends, each of whom invites others to an initial discussion meeting at a home or office. If agreeable, a second meeting may be scheduled.

Those who return usually are genuinely interested in organizing, the details of which may be obtained from the Association's manual, which costs \$5, a sum that is returned if the club becomes a member.

Although some large clubs might have 25 or more members, O'Hara believes most clubs initially operate best with about 12.

Officers generally are elected at the second meeting, and two or three members are assigned to research and give reports on stocks. A broker also is chosen tentatively and invited to attend future meetings.

The most common investment per person is \$20 to

40 Years Ago Today

April 21, 1936
The Rocky Mount Bucs of the Piedmont League defeated East Carolina Teachers College 8-3 in an exhibition baseball game here today.

The Teachers held their own with the pros in quite a few departments, but a pair of costly errors and a number of walks figured in the sizeable score by the winners.

Each team had six hits. Wells, who started on the mound for Coach Bo Farley's nine, yielded only two hits in his four innings. However, the safeties were mixed with four walks to produce four runs.

No player on either team made more than one hit. Ayers and S. Hinton of the Teachers each hit doubles for the game's only extra-base blows.

—James Kyle

The Daily Reflector
INCORPORATED
209 Cotanche Street, Greenville, N.C. 27834
Established 1882
Published Monday Through Friday Afternoon and Sunday Morning

DAVID JULIAN WHICHARD, Chairman of the Board
JOHN S. WHICHARD—DAVID J. WHICHARD
Publishers
Second Class Postage Paid at Greenville, N. C.

SUBSCRIPTION RATES
Payable in Advance
Home Delivery By Carrier or Motor Route Monthly \$3.00
By Mail
One Year \$36.00
Six Months 18.00
Three Months 9.00

MEMBER OF ASSOCIATED PRESS
The Associated Press is exclusively entitled to use for publication all news dispatches credited to it or not otherwise credited to this paper and also the local news published herein. All rights of publications of special dispatches here are also reserved.

UNITED PRESS INTERNATIONAL
Advertising rates and deadlines available upon request.
Member Audit Bureau of Circulation.

Less Poundage

Tobacco poundage sales figures have been tabulated for the Farmville and Greenville markets since the final designation date April 2. The records show that the poundage designation is lower than last year. According to J.N. Bryan, Sales Supervisor of the Greenville Tobacco Board of Trade, \$5,866,827 pounds have been designated in the Greenville Tobacco Market this year while 63,194,162 pounds were designated last year.

According to Lewis Williams, Sales Supervisor of the Farmville Tobacco Board of Trade, 34,822,603 pounds have been designated in the Farmville Tobacco Market this year while 41,445,835 pounds were designated last year.

Bank Account Inquiry Upheld

WASHINGTON (AP) — The government has the right to seize or study the records of your bank account and you don't have a constitutional right to know that federal agents are doing so, the Supreme Court says.

And in another privacy case, the court handed down a decision that could mean millions of government personnel and medical files will now be open to limited public scrutiny.

In a 7 to 2 decision on Wednesday, the court said bank customers have no right to contest government subpoenas of their records because the records belong to the bank.

A bank's customers, the justices said, have "no legitimate expectation of privacy" in bank

transactions that naturally involve bank employees who might tell the government what the records contain.

Since the customer should not think his account is private, the court said, he has no right to expect that the bank or the government will tell him if his account records have been seized or examined.

Justice Lewis F. Powell, writing the decision for the majority, said the bank's failure to notify the customer constitutes "a neglect without legal consequences, however unattractive it may be."

Checks, deposit slips and other records the government requires banks to keep "are not confidential communications but negotiable instruments to

be used in commercial transactions," Powell wrote. He said the documents only contain information the customer has voluntarily allowed to be exposed to banks and their employees.

"The depositor takes the risk, in revealing his affairs to another, that the information will be conveyed by that person to the government," the majority decision said.

The ruling reversed a decision by the 5th U.S. Circuit Court of Appeals, which suppressed bank records of Mitchell Miller of Macon, Ga., tried for operating an illegal whiskey still and other charges.

In the other case involving personal privacy, the court ruled that records of honor code enforcement by military academies may not be withheld from the public on the grounds that the privacy of cadets or

former cadets may be infringed.

In a 5 to 3 ruling that could open millions of government personnel and medical files, the court said federal law protecting secrecy of such files applies only if the government can prove disclosure would be a "clearly unwarranted invasion of personal privacy."

The decision broadened the Freedom of Information Act. Justice Harry A. Blackmun said in his dissent "it is almost inconceivable" that the court appeared willing to allow public disclosure of medical files "and thereby open to the public what has been recognized as almost the essence of ultimate privacy."

Justice John Paul Stevens, who had not been appointed when the court heard arguments on the case in October, did not vote.

In other decisions Wednesday,

the Court ruled 7 to 1 that a person who is suspected of tax evasion but is not under arrest is not entitled to be advised of his constitutional rights before Internal Revenue Service Agents can question him. And the justices voted 8 to 0 that targets of federal criminal probes cannot escape subpoenas for financial records by giving the data to their lawyers.

Buchwald...

(Continued from page 4) you'll decimate Las Vegas. You'll leave a vast desert behind where they once stood."

"That's not my problem. When I bought them I didn't promise anyone I'd keep them there forever."

"All right, if you say so. What about the Glomar Explorer, the ship the CIA used to try to raise the Russian submarine?"

"I don't want it. It caused me too much trouble. Besides, I didn't pay for it—the CIA did. But I want all the films I made in Hollywood."

A lawyer wrote it all down on a yellow legal pad. Then he said, "I have one question, sir. How do you expect to take all your worldly goods with you?"

"I want everything crated and ready. When the time comes I want a truck to drive up to the back door and load the stuff on it. It's to be done at midnight, out of sight of any prying eyes or nosy newspapermen. If one word of this leaks out, you're all fired."

"Yes, sir. We'll make sure it's done in utmost secrecy."

"And I want the three of you to come with me in case I have trouble at the other end."

"Mr. Hughes, you have to be kidding."

"I've never been more serious in my life."

"The three of us are tied up in court for the next few years, but we'll find three junior partners that I'm sure will be happy to go."

"All right. But if they make one mistake, your law firm will lose the entire Hughes account."

Brody's
Downtown
Pitt Plaza

You Can
Find Your
Look At
Brody's

for
openers...



"CUFFIA"
• Black Patent
• White
\$21



"DELLA"
• Bone
\$21

How about rejuvenating your Summer things with breezy sandals! Bandolino's breezy casuals lay the groundwork for a free 'n easy season... openly exposed for wherever a sunny day finds you!



"TRINA"
• Bone
• White
\$20

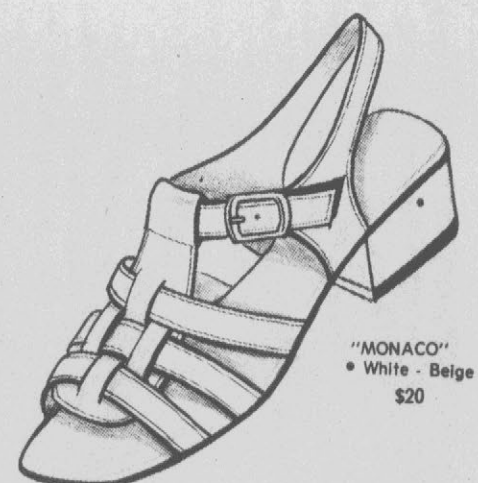

"MONACO"
• White - Beige
\$20

bandolino

Brody's
DOWNTOWN
PITT PLAZA

'Volunteer Week' Set

The week of April 25-30 has been proclaimed by Mayor Percy R. Cox as Greenville Volunteer Week.

In his proclamation, Cox pointed out that "we are a nation of people who thrive on helping others as well as ourselves to a better life."

He observed, "This nation was founded upon a spirit of voluntarism, and today one out of every five Americans is making a gift of time and talent in some kind of volunteer service—helping others or working for a cause—and this great grass roots movement is growing."

Saying that "anyone, young or old, rich or poor, can be a volunteer," Cox asserted, "Our communities and our county will benefit as more and more of us bestow the priceless gift that comes only when people give of themselves."

Greenville, he added, "has instituted a special office, Volunteer Greenville, to facilitate the placement of volunteers so that their time and efforts can best be given."

Cox urged all local citizens to "observe this week by calling Volunteer Greenville and pledging to devote a few hours each week and more, if possible, give aid to some needy individual or cause."

Slave Cemetery

NEW BERN, N.C. (AP) — A large slave cemetery has been found on land that could be affected by expansion of Simmons Knott Airport, an East Carolina University archaeologist says.

Dr. David Phelps, who conducted studies for an environmental impact statement on the airport expansion, said Wednesday 42 graves were found Tuesday in a portion of a 25-acre site. Residents said the site had been used by slaves and their descendants until the 1940s.

Phelps said he had "no reason to doubt" that hundreds of graves lay under the plowed fields and overgrown areas.

Joseph M. Freeman, a spokesman for a New Bern firm drawing up a master development plan for the airport, said the site was partly within an area needed as a buffer zone if the runway were enlarged.

He said he could not say immediately how the findings would affect the development plan.

Goldsmith Col...

(Continued from page 4)

years of their acquisition. But banks, investment trusts and other registered companies would not be taxed on capital gains. A house or apartment listed as the owner's "main residence" would also be exempt, but not additional homes.

The rate of the tax would vary, decreasing by 3.3 per cent a year after acquisition and depending on the taxpayer's total income and number of dependents.

Your Money...

(Continued from page 4)

didn't pay much attention to it."

"People generally prefer to have their savings a little less accessible than their checking accounts," Poole said. Also, it's a lot of trouble for little profit, he said. In three days, \$100 earns only four cents and in 30 days it earns only 43 cents.

Charles Valentine, assistant vice president of First Union National Bank, admitted it could be costly to his company which, like NCNB, offers free checking with no minimum balance to some customers. But, he said, "It's a change we've got to adjust to."

One defense the banks have is the ability to perform the same service. But, by law, banks can only pay 5 per cent interest and not all banks offer daily earnings on savings.

The issue is viewed by many in the industry as just another step toward the day when federal law will be changed to allow S&Ls to offer checking accounts that pay interest. A bill that would do just that is now before the House Banking Committee.

WHYZZIT? WE ALWAYS SEEM TO ARRIVE AT THE SUPERMARKET WHEN THE BAKERY DEPT. LOOKS LIKE THIS...



— AND LEAVE JUST AS YOU-KNOW-WHO DRIVES UP!



Thanks to MRS. GEORGE CONSANI CORTE MADERA, CALIF. CONSANI'S LAW: THE EARLY BIRD NEVER GETS THE WORM

4-22

Brody's Weekend Fashion Savings

DOWNTOWN
PITT PLAZA

Dress Savings...

- One Group Of Better Missy Dresses
- Sizes 8 to 20. • New Spring styles!

NOW SAVE **20%**

- One Group Of Junior Dresses
- Sizes 5 to 15. • Styled for Spring!

NOW SAVE **25%**

Sportswear Savings....

- Groups Of Missy Coordinates And Separates

NOW SAVE **20% TO 50%**

- One Group Of Junior Blazers
- Denims. • Assorted fashion looks and fabrics.

NOW SAVE **50%**

- One Group Junior Pants And Jeans

NOW SAVE **25%**

- Group Of Junior Tops And Sweaters

NOW SAVE **33 1/3%**

Shoe Savings...

- One Group Of Ladies' Spring Shoes
- By Famous Makers. • Dress and casual styles!

NOW SAVE **20%**

- One Group Of Children's Shoes
- Pitt Plaza Only • Spring Styles!

NOW SAVE **20%**

Coat Savings...

ENTIRE STOCK OF
Spring Coats

• Sizes 8 to 20 • White, Navy, Pastels

REDUCED!

20% off lovely quilted print bedspreads.

Sale 16.80 Twin; reg. \$21
 'Floral Medley' features bouquets of tulips and irises on a soft pastel background. Machine washable polyester/cotton with polyester fiberfill.
 Full; reg. \$24 **Sale 19.20**
 Queen; reg. \$31 **Sale 24.80**

Sale \$24 Twin; reg. \$30
 'Ribbonette' spread has a ribbon and flower print, eyelet ruffling. Easy-care polyester/cotton, polyester fill.
 Full; reg. \$35 **Sale \$28**
 Queen; reg. \$45 **Sale \$36**
 King; reg. \$54 **Sale \$43.20**



Save on colorful printed percale sheets.

Sale 3.96 Twin; reg. 4.99
 'Romance' no-iron sheets feature a graceful ribbon and flower print on colored cotton/polyester percale.
 Full; reg. 5.99 **Sale 4.96**
 Queen; reg. 9.99 **Sale 7.46**

Pillow cases, pkg. of 2; reg. 4.29 **Sale 3.76**

Sale 4.22 Twin; reg. 5.49
 'Ribbonette' sheets in no-iron cotton/polyester percale with ribbon and flower print, eyelet ruffle trim.
 Full; reg. 6.49 **Sale 5.22**
 Queen; reg. 10.49 **Sale 7.92**

Pillow cases, pkg. of 2; reg. 4.59 **Sale 4.02**
 Flat and fitted are the same prices.

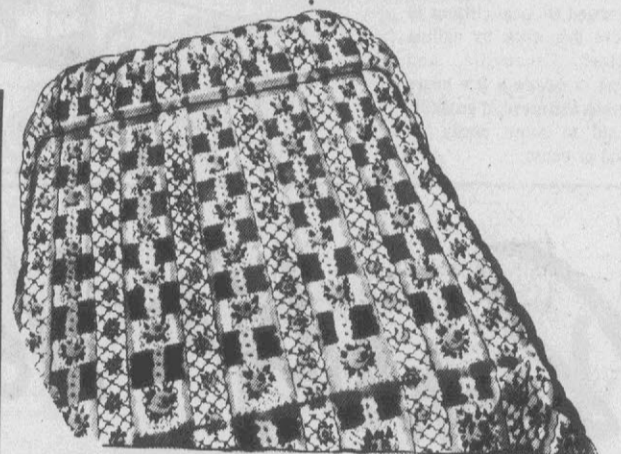
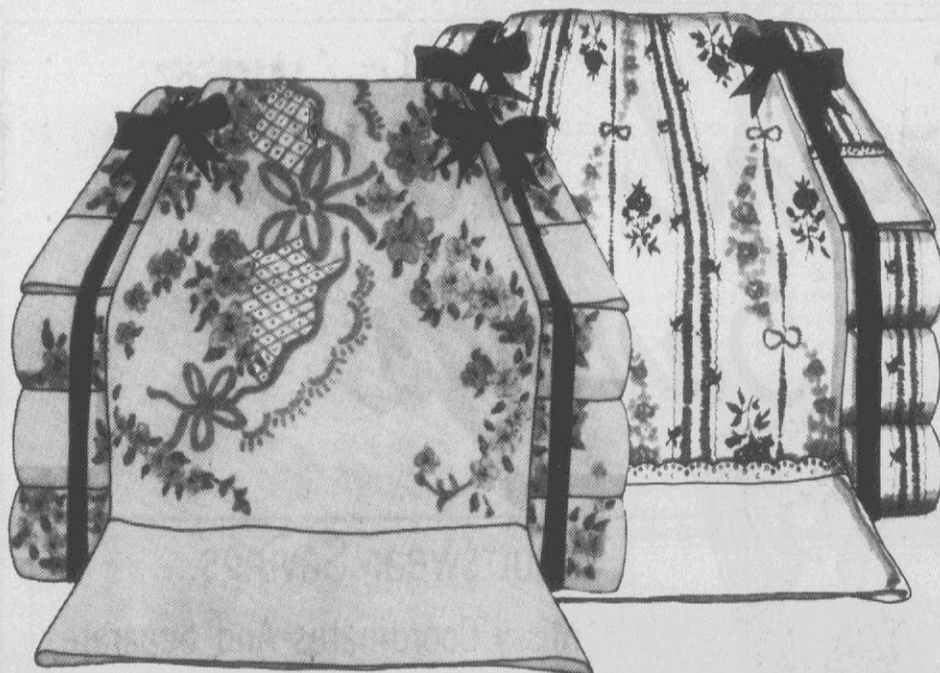

Special buy bedspreads

Twin **10.99** Assorted patterns
 Full **13.99** to choose from.

Sale prices effective through Saturday.

Save 20% on our Spring Draperies

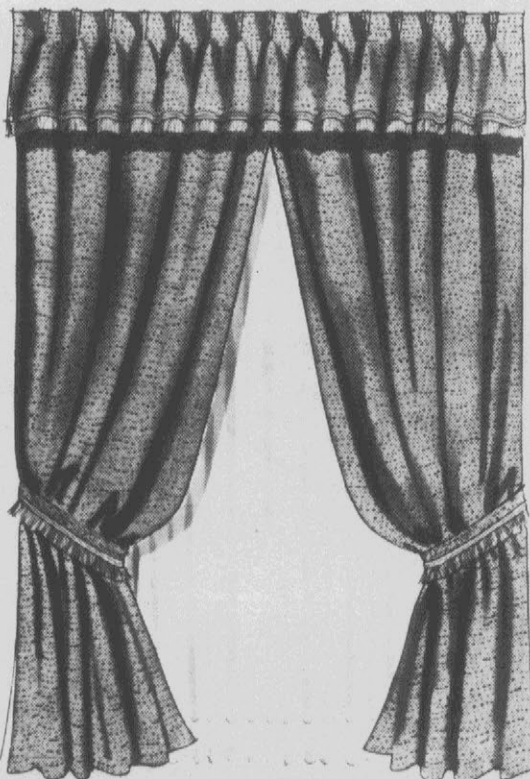

Sale 11.20 pr. 50x36 or 45"; reg. \$14

'Jewel-Tex' draperies are textured polyester with rayon/cotton, or acrylic. They're thermal backed, machine washable and dryable, no-iron. Many colors and sizes.

— 50" x 63" reg. \$16 **Sale 12.80 pr.**
 50x84"; reg. \$17 **Sale 13.60 pr.**

Sale 9.20 pr.

50x45"; reg. 11.50

'Tique' draperies are jacquard woven rayon or cotton/polyester damask with acrylic foam backing for insulation. Machine washable, dryable, no-iron. Many colors, sizes.

— 50" x 63" reg. 12.50 **Sale \$10 pr.**
 50x84"; reg. \$13 **Sale 10.40 pr.**

Sale prices
 effective thru Saturday!

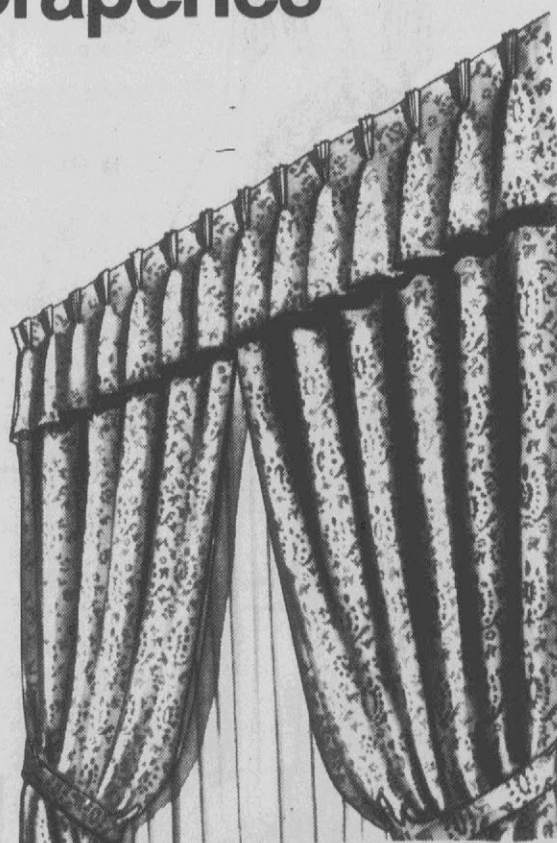

Kitchen Appliance Sale

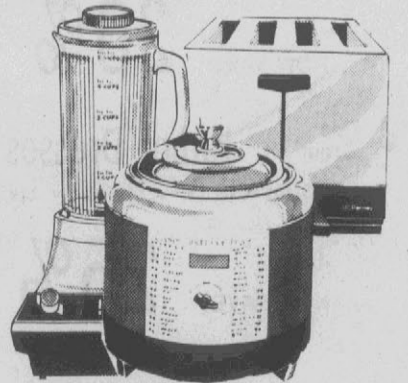

Sale 19.99

Reg. 24.99. Save \$5. 14-speed deluxe blender with range flash blend control. Removable stainless steel cutting assembly. 40 oz. glass jars.

Sale 14.99

Reg. 17.99. Save \$3. 4-slice toaster with a single control—for expert toast color. Includes hinged crumb tray. Easy-to-clean chrome finish.

Reg. 16.99. Save \$2. 5-qt. cooker/fryer. Teflon® lined for easy cleaning. Has a large 5-qt. capacity, automatic thermostat and cooking chart. In avocado, chrome or poppy.

JCPenney

Charge it at JCPenney, Pitt Plaza, Greenville, Open Monday thru Saturday from 10 A.M. 'Til 9:30 P.M.

Our Final Tiller Sale!

We have too many tillers and time is catching up with us. All prices have been drastically reduced., but hurry in, at these prices they will sell out fast...and we'll have no more this year.

Save \$130 on our 8 hp Tiller

Originally 429.99
Now **299⁹⁹** (Model 3032)

JCPenney 8 HP chain drive tiller with horizontal Briggs and Stratton engine. Features two stage air filter, adjustable depth bar. End tines removable for narrower widths.

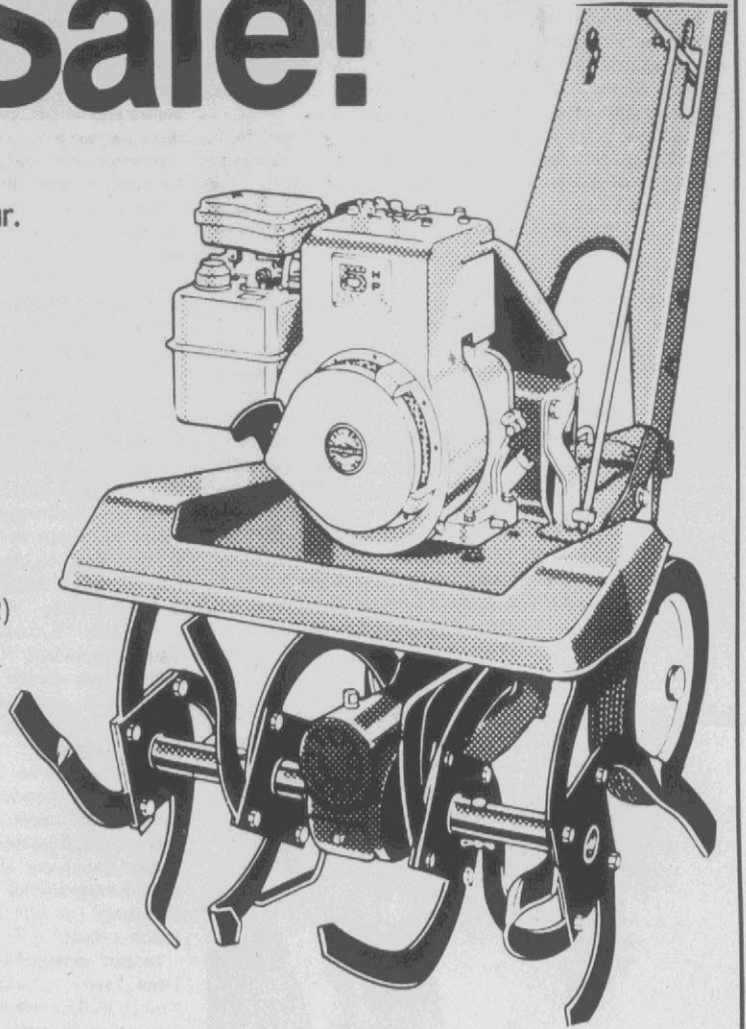

Save \$80 on our 5 hp Tiller

Originally 299.99
Now **219⁹⁹** Model 3031

JCPenney 5 HP gear drive tiller has Briggs and Stratton engine, power reverse. End tines removable for narrower widths.

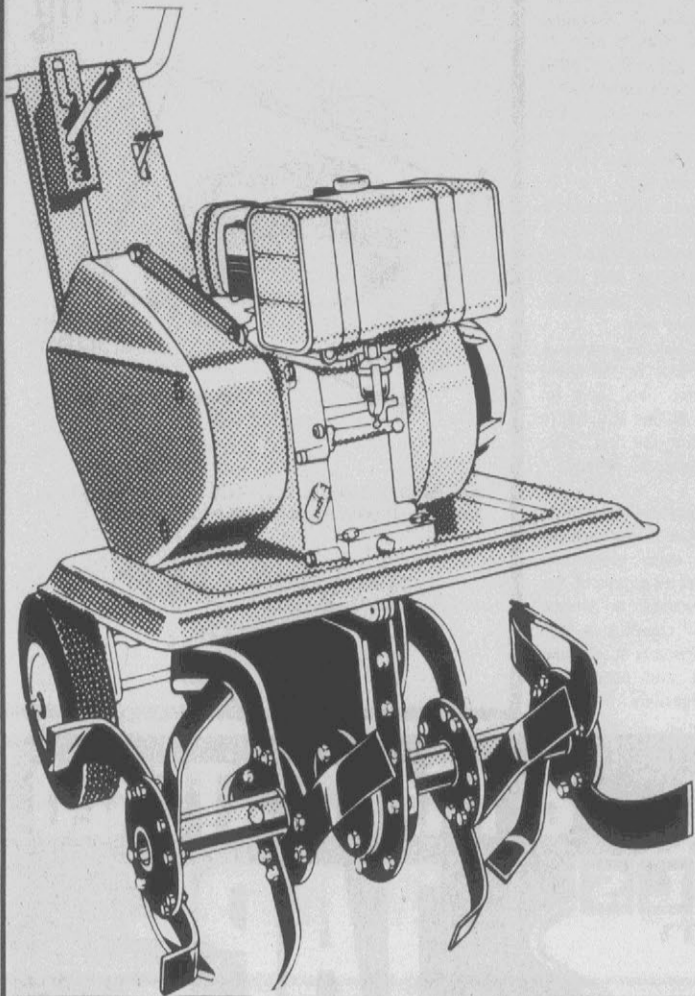

Notice to our customers ... We cannot accept any layaways or special orders on this clearance merchandise. When our present inventory is exhausted there will be no more available.



Sale 69.99

Reg. 79.99. Men's 26" 10-speed racer. Stem mounted gear shifter, safety levers, rat trap pedals. Yellow finish. Women's 26" 10-speed racer, Reg. 79.99, Sale 69.99

Save \$10 on this 10-speed.

Sale 104.99

Reg. 119.99. Save \$15. Competition Motocross bike. Specially designed for off-the-road use. Has reinforced hinged frame. With heavy duty front and rear spring suspension and heavy duty rims and spokes. Knobby tires.



Sale 64.99

Reg. 69.99. Save \$5. Women's 26" touring 3-speed. Front and side pull caliper hand brakes, handlebar mounted shifter, chrome fenders. With butterscotch finish frame. Men's 26" touring 3-speed, Reg. 69.99, Sale 64.99



15% off all Wilson Tennis Rackets

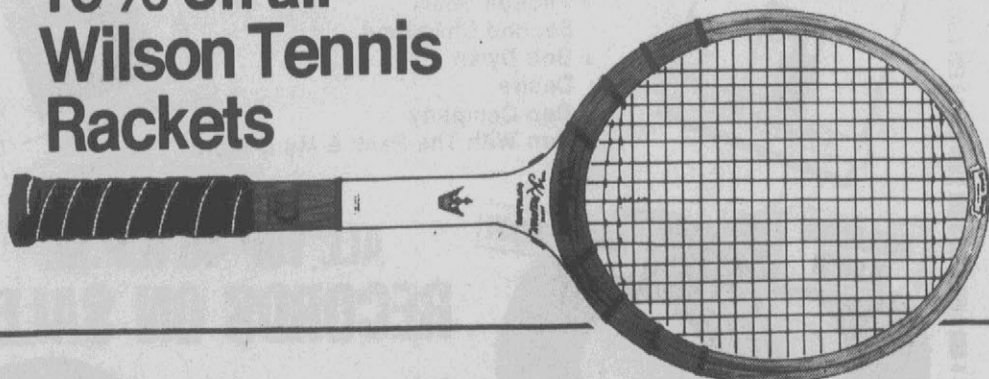

25% off

Our best 78 series fiber glass belted tires.



EL Tigre 278. Features 2+2 construction of polyester cords and fiber glass belts. In the wide 78 and 70 series profile. Whitewall tubeless. No trade-in required.

Tire size	Save	Reg.	Sale	+ fed. tax
A78-13	7.25	29.00	21.75	1.75
C78-14	10.00	40.00	30.00	2.05
D70-14	10.25	41.00	30.75	2.24
E78-14	11.00	44.00	33.00	2.27
F78-14	12.50	46.00	33.50	2.43
G78-14	12.00	48.00	36.00	2.60
H78-14	12.75	51.00	38.25	2.83
G78-15	12.75	51.00	38.25	2.65
H78-15	13.25	53.00	39.75	2.87
L78-15	14.75	59.00	44.25	3.08

Sale prices effective thru Saturday.

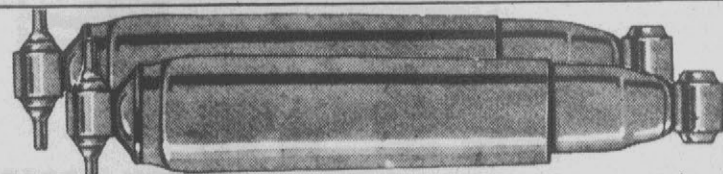

3.10 off heavy duty shocks. Sale 5.39

Reg. 8.49. JCPenney heavy duty shock absorber. Features 1-3/16" piston with "O" ring design. Full replacement warranty for as long as you own your car or truck. Available for most American and foreign cars. Expert installation available at extra cost.

WARRANTY: For as long as you own your private car or truck, we will replace this JCPenney Heavy Duty Shock Absorber if it fails due to defects in material or workmanship, or, if it wears out, with a new one of equal or superior value. And if the original Heavy Duty Shock Absorber was installed by JCPenney, we will install the replacement Shock Absorber free of charge. Just contact us.

Wheel alignment 10⁸⁸

Here's what you get:

- Suspension inspection
- Set caster and camber
- Adjust toe-in
- Road test

*Most U.S. and many foreign cars. Add \$2 each for cars equipped with either air conditioning or torsion bars.

JCPenney

Charge it at JCPenney, Pitt Plaza, Greenville, Open Monday thru Saturday from 10 A.M. 'Til 9:30 P.M.

Pres. Ford Denies Inferiority In Nat'l Defense

By The Associated Press
President Ford, after calling his challenger's charges of U.S. military inferiority "complete and utter nonsense," headed for Indiana today and some campaigning for the state's May 4 presidential primary.

Ford didn't mention Ronald Reagan by name Wednesday, but it was clear he had the former California governor in mind when he said, "The American people have had enough distorted allegations that we have become a second-rate nation."

Ford's defense policy has been a major theme in Reagan's campaign for the GOP nomination, and the challenger persisted in his attack Wednesday as he stumped through Georgia.

Democrats, meanwhile, hoped from state to state Wednesday — Washington Sen. Henry M. Jackson campaigned in at least three — but Pennsylvania and its election next Tuesday was the focal point.

Ford's scheduled trip to Indiana — ending a 12-day break in his campaign travels — included stops at Indianapolis and Evansville. The President is due in Georgia Friday.

Reagan planned to campaign in Alabama today and in Indiana on Friday.

Voting in Georgia and Alabama — as well as Indiana — is May 4.

The President, in a speech in Washington to a meeting of the Daughters of the American Revolution, urged that the issue of the country's military might "be addressed honestly, factually and fairly."

Reagan, in Texas last week, said, "We're No. 2 in a world

where it is dangerous to be second best."

Ford also said Wednesday that Reagan's competition has been a plus for him and "so far there has not been any serious divisiveness within the party." He said he rates Reagan as among those Republicans he would consider for vice president.

Asked in an Oval Office interview with Washington correspondents for Texas newspapers if former Texas Gov. John Connally also was on that list, the President promptly replied, "Oh, yes."

Former Georgia Gov. Jimmy Carter, leading Democrats in the race for nominating delegates, said Wednesday he considers Minnesota Sen. Hubert H. Humphrey his main opponent in the upcoming election in Pennsylvania.

Humphrey is not an announced candidate, but Carter said in Finleyville, Pa., that the former vice president "is the only one to challenge me in popular support."

Labor leaders in the state and some Democratic officials have urged voters to elect uncommitted delegates who can support Humphrey at the national convention this summer. Humphrey has said he would accept a draft.

Jackson, Arizona Rep. Morris Udall and Alabama Gov. George Wallace are competing for votes in Pennsylvania. Both Udall and Wallace campaigned in the state Wednesday, while Jackson spent time in Indiana

and later Kentucky.

There were these other developments Wednesday:

—Jackson demanded an "absolute apology" from Vice President Nelson A. Rockefeller over a report in the Atlanta Journal that Rockefeller suggested privately that Communists have infiltrated Jackson's staff.

Rockefeller refused to comment on the report.

Jackson said that if Rockefeller refuses to comment "he should no longer hold the office of vice president."

Rockefeller reportedly made the comments in a closed-door meeting with 30 to 40 Georgia Republican leaders in Atlanta

change or a "conversion of conscience," according to the three, whom the paper did not name.

Jackson was due in Detroit today to kick off his campaign for Michigan's May 18 primary.

—Ford announced plans for his longest campaign trip to date, a four-day swing into Louisiana and Texas next week. Ford and Reagan meet head-on in Texas' May 1 primary.

—Sen. Frank Church of Idaho, campaigning in Ogallala, Neb., for the state's May 11 Democratic primary, called himself "as common-sense a Democrat as most Americans when it comes to keeping this country out of senseless and futile foreign wars."

—Robert Short, a Minneapolis hotel and trucking firm owner and a key Humphrey supporter, said he expects the 1968 presidential nominee to become an active candidate soon.

"At some point, he's obviously going to come to the same conclusion that I've come to, which is that no one is going to be nominated on the first ballot and he's as viable as anybody," Short said.

—Ford supporters claimed an edge on Reagan in the race for district and state convention delegates after two days of Republican caucuses in wards, townships and counties in Missouri. The process of electing state district and party convention delegations continues

through the end of the week. With most of the results from Tuesday's Democratic caucuses in Missouri tabulated, 64 per cent of the delegates to congressional district meetings were uncommitted. Carter had 14 per cent of the delegates; the rest of the candidates were far behind.



A \$1,000 CHECK... was presented to Hospital Gifts Committee Chairman Henry Leslie (right) by Bruce Whitaker, Commander of American Legion Post 39. The local Post is giving the money to be used in the erection of a 40-foot flag staff on the grounds of the new Pitt Memorial Hospital. Flags of the United States and North Carolina also were presented.

Wins New Trial In Killing Case

RALEIGH (AP) — A Hickory woman who faced a 15 to 18-year prison term for killing her husband won a new trial Wednesday from the state Court of Appeals.

The court said Phyllis Ann Christopher was entitled to a new trial in the pistol slaying of Jack R. Christopher because the trial judge failed to instruct the jury it would return a verdict of manslaughter.

She was convicted of second-degree murder at her trial in Burke Superior Court.

Deputy Grand Regent To Be Chapter Guest

Mrs. Margaret Bost of Salisbury, deputy grand regent for North and South Carolina, will be guest speaker at a meeting of Greenville Chapter No. 1308 tonight at eight o'clock at the Moose Temple, according to Mrs. Wilma Turner, chapter senior regent.

This is Mrs. Bost's first official to the Greenville Chapter. She will speak on the value of WOTM membership, to the individual and to the chapter.

WOTM members from neighboring chapters have been invited and Mrs. Turner urged the attendance of all members of the Greenville Chapter.

Following the meeting, refreshments will be served in the auditorium.

for Mom...
Her
Special Ring
In Sterling Silver

With Two Birthstones

\$12⁸⁸

Additional Birthstones \$3.00 Each. 42 Additional Styles Available In Sterling, 10K Gold or 14K Gold.

SASLOW'S
Jewelers
406 Evans
South Mall
Downtown Greenville
752-3708

QUICK COPIES—WHILE YOU WAIT

1ST 5 COPIES 10¢ EA. PRINTED COPIES
NEXT 10 COPIES 5¢ EA. 200 — \$6.00
ALL OVER 15 COPIES 3¢ EA. 300 — \$7.00
8 1/2 x 11 BOND—BLACK INK 500 — \$9.00

Prices Based On Each Original

MORGAN PRINTERS, Inc.
211 WEST 9th ST. ★ PHONE 752-5151

SHERWIN WILLIAMS INTRODUCING BEAUTY LAST LATEX HOUSE PAINT

save \$3.00 gal.
sale 7⁹⁹ Gal.
After sale price \$10.99 gal.

Durable, colorfast. Resists chalking, blistering, peeling.

AND SAVE \$3.00 ON THESE GREAT FAVORITES

A-100™ LATEX HOUSE PAINT
Our best hiding, longest lasting flat latex house paint.

GLOSS LATEX HOUSE & TRIM PAINT
Beautiful gloss. Use on any exterior surface, from siding to shutters.

YOUR CHOICE sale 10⁹⁹ Gal. Reg. \$13.99 gal.

save \$5.00 to \$10.00 ALUMINUM STEP & EXTENSION LADDERS

	Reg.	Sale	Save
6' Step	\$21.95	\$16.95	\$ 5.00
16' Extension	\$32.95	\$25.95	\$ 7.00
20' Extension	\$41.95	\$33.95	\$ 8.00
24' Extension	\$52.95	\$42.95	\$10.00

SALE ENDS MAY 1st

WE MAKE YOU FEEL RIGHT AT HOME

GREENVILLE
TENTH ST. AND DICKINSON AVE.
752-4171

8-TRACK STEREO TAPE SPECIALS!

ON SALE THURSDAY, FRIDAY & SATURDAY

Entire stock of \$7.95 list 8-Track Tapes on sale. Thousands of artists to choose from. Pick your favorite from such labels as Warner Bros., MCA, A&M, Arista, Columbia or RCA.

NOW ONLY 5²⁹ EA.
SERIES 7.95 CODE K

- The Doobie Brothers
- Captain & Tennille
- Olivia Newton John
- Melissa Manchester
- Bay City Rollers
- Bad Company
- Bob Dylan
- Phoebe Snow
- Eagles
- David Bowie

INCLUDING OLDEST! SHOP EARLY! TOP HITS!

ALL TOP 45 R.P.M. RECORDS ON SALE!

Choose from all your favorites. Start that collection or finish the one you already have. Don't pass up this dynamite sale!

77¢
MFG. LIST PRICE \$1.29
NOT RESPONSIBLE FOR TYPOGRAPHICAL ERRORS

OPEN 10:00 A.M. TO 9:00 P.M. MONDAY THRU SATURDAY.

Industry Pays More Attention Now To Complaints

By LOUISE COOK
Associated Press Writer
"I found a stem in my green beans."
"There aren't enough shopping carts."
"I was shortchanged at the checkout."

The complaints are typical of those received by a large East Coast supermarket chain. A store spokesman, who refused to be identified by name or store, said they are among thousands and thousands which come in each year.

Food prices and quality have been the focus of consumer discontent in the 1970s, prompting supermarket chains to pay greater attention to complaints.

But the food stores are not alone in trying to keep the customer happy. A survey by the Conference Board, a business research group, found a growing number of companies establishing full-time consumer affairs departments.

The board mailed questionnaires to 1,250 companies for its survey, published early in 1974. It got responses from 433 firms and of these, 180 reported having a consumer affairs department.

Asked how many companies now have such divisions, E. Patrick McGuire, a senior research analyst for the board and author of the original study, said, "I would guess it has to be close to the 500 mark."

Some consumer groups, including the Consumer Federation of America, have argued that many of these departments are window dressing, designed to take the sting out of complaints without actually making any changes in basic policy.

"They are owned by the other side," said Carol Tucker Foreman, the federation's executive director, in discussing the company-employed consumer affairs personnel. "They are quite literally in an untenable position."

The Conference Board, in its original study, said: "It would be an overstatement to assert that simply because a firm has a consumer affairs unit, it has necessarily launched an effective consumer relations effort."

McGuire said there is "some merit to the charge" of window dressing in that a few companies "commit an amount of resources to the task that is in no way commensurate with the task."

"One can argue that not enough is being done," he said but to dismiss the whole thing is "to ignore what a lot of well-intentioned people are doing."

McGuire said it is in the company's own interest to make sure that complaints are handled effectively because Conference Board studies have shown that "in many instances, when you get one complaint, that represents up to 40 aggrieved customers."

Five hundred complaints could mean 20,000 disgruntled customers ready to turn to the competition if they aren't satisfied, McGuire said.

Business is still touchy when it comes to talking about customer dissatisfaction, partly because complaint information can give the competition an advantage.

They are reluctant to give specifics about the number of complaints and whether they are increasing or decreasing.

The supermarket spokesman quoted above did say that about 40 per cent of the letters and phone calls the chain receives concern products. That's the stem in the green beans. If the

store gets enough complaints about a particular item, it's removed from the shelves.

The rest of the communications are split between store operations — too few carts — and miscellaneous issues, including compliments.



The most rapidly burgeoning category of miscellaneous queries deals with product information," the spokesman said. People want detailed facts about nutrition and ingredients.

They read about problems with Red Dye No. 2, recently banned by the Food and Drug Administration, and they want to know which products contain it. They are concerned about fluorocarbons in aerosols.

The chain spokesman said the search for specific information has grown in the last two or three years. "It's much more scientific and detailed than: 'Hey, I don't like your green beans.'"

Customers with a complaint about an individual product generally get a refund in the form of a gift certificate good at any of the chain's outlets. Proof of purchase usually is not required.

The relatively liberal refund policy can lead to abuse. "We have to have faith in our customers," the spokesman said, but conceded that the chain does have problems with chronic complainers who will write as often as 20 times. Once the complainer is identified, he or she frequently gets a follow-up phone call asking what is wrong. The complaints drop off.

Why not simply tell the chronic complainer to shop elsewhere? "You can't afford to lose a customer," the spokesman said. "Assume the average shopper spends \$50 a week. She shops in the store for a five-year period. She brings two friends with her."

The loss of that customer and her friends could mean a potential loss of almost \$40,000 in sales. With supermarket profits running at about 1 per cent of sales, the lost customer could mean \$400 in lost profits over five years. It may not seem like much, but it can add up.

Not all complaint departments — or customer relations offices — as some companies prefer to call them — are new. General Motors Corp. set up a formal corporate procedure for handling owner complaints in 1928. The basic complaint procedures have remained generally unchanged for the past decade. Grievances are handled through GM's six divisions — five car and one truck.

Customers are told to follow a three-step procedure: first, complain to the dealer; if you don't get satisfaction, call the nearest zone office for your type of vehicle; if you're still not happy, write to the customer service office at the division headquarters.

Glen Warren, manager of customer relations said the complaint procedure, with addresses, is explained in the owner's manual — "which everybody gets and nobody reads" — in the warranty pamphlet and on a placard at the dealer.

Warren said GM's car and truck divisions get 60,000 to 75,000 complaints a year, depending on the number of vehicles sold and whether there is a lot of publicity about a particular problem. He declined to be more specific.

Warren said the number of complaints in relation to the number of vehicles sold "has decreased over the past five years." In fact, he said, the ratio of complaints to vehicles is lower today than it was in the 1930s.

Why then do state and local consumer agencies say they get more complaints about automobiles than any other item? "Cars are exposed to such varied conditions and people make such demands on them that it's not surprising you get complaints," said Warren.

He said General Motors dealers handle 200,000 transactions a day, including sales and repairs. "Every one is an opportunity for someone to make a mistake."

Warren said people have become increasingly aware of their rights. They know what they are entitled to. They also know "what they're not entitled to." Warren said, "but they are encouraged not to accept that concept." By whom? "So-called consumerists."

The greatest number of GM complaints "has to do with failure to get the job done right the first time" at the dealership, Warren said. He said the average complaint is resolved in about two weeks.

Why then do state and local consumer agencies say they get more complaints about automobiles than any other item? "Cars are exposed to such varied conditions and people make such demands on them that it's not surprising you get complaints," said Warren.

He said General Motors dealers handle 200,000 transactions a day, including sales and repairs. "Every one is an opportunity for someone to make a mistake."

Warren said people have become increasingly aware of their rights. They know what they are entitled to. They also know "what they're not entitled to." Warren said, "but they are encouraged not to accept that concept." By whom? "So-called consumerists."

The greatest number of GM complaints "has to do with failure to get the job done right the first time" at the dealership, Warren said. He said the average complaint is resolved in about two weeks.

Warren said people have become increasingly aware of their rights. They know what they are entitled to. They also know "what they're not entitled to." Warren said, "but they are encouraged not to accept that concept." By whom? "So-called consumerists."

Warren said people have become increasingly aware of their rights. They know what they are entitled to. They also know "what they're not entitled to." Warren said, "but they are encouraged not to accept that concept." By whom? "So-called consumerists."

Warren said people have become increasingly aware of their rights. They know what they are entitled to. They also know "what they're not entitled to." Warren said, "but they are encouraged not to accept that concept." By whom? "So-called consumerists."

Warren said people have become increasingly aware of their rights. They know what they are entitled to. They also know "what they're not entitled to." Warren said, "but they are encouraged not to accept that concept." By whom? "So-called consumerists."

Warren said people have become increasingly aware of their rights. They know what they are entitled to. They also know "what they're not entitled to." Warren said, "but they are encouraged not to accept that concept." By whom? "So-called consumerists."

Warren said people have become increasingly aware of their rights. They know what they are entitled to. They also know "what they're not entitled to." Warren said, "but they are encouraged not to accept that concept." By whom? "So-called consumerists."

Warren said people have become increasingly aware of their rights. They know what they are entitled to. They also know "what they're not entitled to." Warren said, "but they are encouraged not to accept that concept." By whom? "So-called consumerists."

Warren said people have become increasingly aware of their rights. They know what they are entitled to. They also know "what they're not entitled to." Warren said, "but they are encouraged not to accept that concept." By whom? "So-called consumerists."

Warren said people have become increasingly aware of their rights. They know what they are entitled to. They also know "what they're not entitled to." Warren said, "but they are encouraged not to accept that concept." By whom? "So-called consumerists."

Warren said people have become increasingly aware of their rights. They know what they are entitled to. They also know "what they're not entitled to." Warren said, "but they are encouraged not to accept that concept." By whom? "So-called consumerists."

Warren said people have become increasingly aware of their rights. They know what they are entitled to. They also know "what they're not entitled to." Warren said, "but they are encouraged not to accept that concept." By whom? "So-called consumerists."

Warren said people have become increasingly aware of their rights. They know what they are entitled to. They also know "what they're not entitled to." Warren said, "but they are encouraged not to accept that concept." By whom? "So-called consumerists."

Warren said people have become increasingly aware of their rights. They know what they are entitled to. They also know "what they're not entitled to." Warren said, "but they are encouraged not to accept that concept." By whom? "So-called consumerists."

Warren said people have become increasingly aware of their rights. They know what they are entitled to. They also know "what they're not entitled to." Warren said, "but they are encouraged not to accept that concept." By whom? "So-called consumerists."

Warren said people have become increasingly aware of their rights. They know what they are entitled to. They also know "what they're not entitled to." Warren said, "but they are encouraged not to accept that concept." By whom? "So-called consumerists."

Warren said people have become increasingly aware of their rights. They know what they are entitled to. They also know "what they're not entitled to." Warren said, "but they are encouraged not to accept that concept." By whom? "So-called consumerists."

Warren said people have become increasingly aware of their rights. They know what they are entitled to. They also know "what they're not entitled to." Warren said, "but they are encouraged not to accept that concept." By whom? "So-called consumerists."

Warren said people have become increasingly aware of their rights. They know what they are entitled to. They also know "what they're not entitled to." Warren said, "but they are encouraged not to accept that concept." By whom? "So-called consumerists."

Warren said people have become increasingly aware of their rights. They know what they are entitled to. They also know "what they're not entitled to." Warren said, "but they are encouraged not to accept that concept." By whom? "So-called consumerists."

Warren said people have become increasingly aware of their rights. They know what they are entitled to. They also know "what they're not entitled to." Warren said, "but they are encouraged not to accept that concept." By whom? "So-called consumerists."

Warren said people have become increasingly aware of their rights. They know what they are entitled to. They also know "what they're not entitled to." Warren said, "but they are encouraged not to accept that concept." By whom? "So-called consumerists."

Warren said people have become increasingly aware of their rights. They know what they are entitled to. They also know "what they're not entitled to." Warren said, "but they are encouraged not to accept that concept." By whom? "So-called consumerists."

Warren said people have become increasingly aware of their rights. They know what they are entitled to. They also know "what they're not entitled to." Warren said, "but they are encouraged not to accept that concept." By whom? "So-called consumerists."

Warren said people have become increasingly aware of their rights. They know what they are entitled to. They also know "what they're not entitled to." Warren said, "but they are encouraged not to accept that concept." By whom? "So-called consumerists."

Warren said people have become increasingly aware of their rights. They know what they are entitled to. They also know "what they're not entitled to." Warren said, "but they are encouraged not to accept that concept." By whom? "So-called consumerists."

Warren said people have become increasingly aware of their rights. They know what they are entitled to. They also know "what they're not entitled to." Warren said, "but they are encouraged not to accept that concept." By whom? "So-called consumerists."

Warren said people have become increasingly aware of their rights. They know what they are entitled to. They also know "what they're not entitled to." Warren said, "but they are encouraged not to accept that concept." By whom? "So-called consumerists."

Warren said people have become increasingly aware of their rights. They know what they are entitled to. They also know "what they're not entitled to." Warren said, "but they are encouraged not to accept that concept." By whom? "So-called consumerists."

Warren said people have become increasingly aware of their rights. They know what they are entitled to. They also know "what they're not entitled to." Warren said, "but they are encouraged not to accept that concept." By whom? "So-called consumerists."

Warren said people have become increasingly aware of their rights. They know what they are entitled to. They also know "what they're not entitled to." Warren said, "but they are encouraged not to accept that concept." By whom? "So-called consumerists."

Warren said people have become increasingly aware of their rights. They know what they are entitled to. They also know "what they're not entitled to." Warren said, "but they are encouraged not to accept that concept." By whom? "So-called consumerists."

Warren said people have become increasingly aware of their rights. They know what they are entitled to. They also know "what they're not entitled to." Warren said, "but they are encouraged not to accept that concept." By whom? "So-called consumerists."

Warren said people have become increasingly aware of their rights. They know what they are entitled to. They also know "what they're not entitled to." Warren said, "but they are encouraged not to accept that concept." By whom? "So-called consumerists."

Warren said people have become increasingly aware of their rights. They know what they are entitled to. They also know "what they're not entitled to." Warren said, "but they are encouraged not to accept that concept." By whom? "So-called consumerists."

Warren said people have become increasingly aware of their rights. They know what they are entitled to. They also know "what they're not entitled to." Warren said, "but they are encouraged not to accept that concept." By whom? "So-called consumerists."

Warren said people have become increasingly aware of their rights. They know what they are entitled to. They also know "what they're not entitled to." Warren said, "but they are encouraged not to accept that concept." By whom? "So-called consumerists."

Warren said people have become increasingly aware of their rights. They know what they are entitled to. They also know "what they're not entitled to." Warren said, "but they are encouraged not to accept that concept." By whom? "So-called consumerists."

Warren said people have become increasingly aware of their rights. They know what they are entitled to. They also know "what they're not entitled to." Warren said, "but they are encouraged not to accept that concept." By whom? "So-called consumerists."

Warren said people have become increasingly aware of their rights. They know what they are entitled to. They also know "what they're not entitled to." Warren said, "but they are encouraged not to accept that concept." By whom? "So-called consumerists."

Warren said people have become increasingly aware of their rights. They know what they are entitled to. They also know "what they're not entitled to." Warren said, "but they are encouraged not to accept that concept." By whom? "So-called consumerists."

Warren said people have become increasingly aware of their rights. They know what they are entitled to. They also know "what they're not entitled to." Warren said, "but they are encouraged not to accept that concept." By whom? "So-called consumerists."

Warren said people have become increasingly aware of their rights. They know what they are entitled to. They also know "what they're not entitled to." Warren said, "but they are encouraged not to accept that concept." By whom? "So-called consumerists."

Warren said people have become increasingly aware of their rights. They know what they are entitled to. They also know "what they're not entitled to." Warren said, "but they are encouraged not to accept that concept." By whom? "So-called consumerists."

Warren said people have become increasingly aware of their rights. They know what they are entitled to. They also know "what they're not entitled to." Warren said, "but they are encouraged not to accept that concept." By whom? "So-called consumerists."

Warren said people have become increasingly aware of their rights. They know what they are entitled to. They also know "what they're not entitled to." Warren said, "but they are encouraged not to accept that concept." By whom? "So-called consumerists."

Warren said people have become increasingly aware of their rights. They know what they are entitled to. They also know "what they're not entitled to." Warren said, "but they are encouraged not to accept that concept." By whom? "So-called consumerists."

Warren said people have become increasingly aware of their rights. They know what they are entitled to. They also know "what they're not entitled to." Warren said, "but they are encouraged not to accept that concept." By whom? "So-called consumerists."

Warren said people have become increasingly aware of their rights. They know what they are entitled to. They also know "what they're not entitled to." Warren said, "but they are encouraged not to accept that concept." By whom? "So-called consumerists."

Warren said people have become increasingly aware of their rights. They know what they are entitled to. They also know "what they're not entitled to." Warren said, "but they are encouraged not to accept that concept." By whom? "So-called consumerists."

Warren said people have become increasingly aware of their rights. They know what they are entitled to. They also know "what they're not entitled to." Warren said, "but they are encouraged not to accept that concept." By whom? "So-called consumerists."

Warren said people have become increasingly aware of their rights. They know what they are entitled to. They also know "what they're not entitled to." Warren said, "but they are encouraged not to accept that concept." By whom? "So-called consumerists."

Warren said people have become increasingly aware of their rights. They know what they are entitled to. They also know "what they're not entitled to." Warren said, "but they are encouraged not to accept that concept." By whom? "So-called consumerists."

Warren said people have become increasingly aware of their rights. They know what they are entitled to. They also know "what they're not entitled to." Warren said, "but they are encouraged not to accept that concept." By whom? "So-called consumerists."

Alexander Pledges Not To Make Voters Regret

RALEIGH, N.C. (AP)—Former Transportation Secretary Jake Alexander has announced his candidacy for the Republican nomination for governor, promising he "will never do anything to make the people of North Carolina regret having given me their help."

In making his formal announcement in four news conferences around the state Wednesday, Alexander laid down a six-point program which called for "more realistic budgeting," "greater efficiencies" and doors to the governor's office "opened even wider."

Alexander was asked if that indicated he believed the Republican administration of Gov. Jim Holshouser had fallen

short, he answered that it was a general criticism of all prior administrations. Holshouser was the first Republican governor this century.

Alexander, 52, said about 500 persons attended his pre-announcement rally in Salisbury Tuesday. He said this indicated his broad support. Others in the GOP race are former Human Resources Secretary David Flaherty, Coy Privette, a Baptist minister from Kannapolis, and Wallace McCall, also a minister.

Alexander said little money has been raised so far for his campaign because he only resigned from his transportation job April 9.

He held the first of four news conferences to officially announce his candidacy at the Asheville airport where he described himself as "unique to the political scene," and told

newsmen, "I have a stability and maturity that I haven't seen in the other candidates."

He was accompanied by his wife, Doris, two daughters and two sons at Asheville and at later news conferences at the Greensboro-High Point Airport, the Raleigh-Durham Airport and Charlotte's Douglas Airport.

A Forest City native, Alexander is a Salisbury businessman who came to Raleigh in 1974 as motor vehicles commissioner. He was named transportation secretary in April 1975.

On budget matters, Alexander said he believes state workers and teachers deserve a pay increase but opposed raising taxes to get the money. He suggested that spending be cut instead but would not say where the cuts should be made except to suggest trimming payrolls 10 per cent.



Enchantment for a lifetime.



A perfect diamond-guaranteed by Keepsake for perfect clarity, precise cut, fine white color.

Keepsake
Registered Diamond Rings

Lord's
Jewelers

On The Downtown Mall
425 Evans St.
Phone 752-6753
Open Daily 9:30 - 5:30
Sat. 9:30 - 6:00
Ruben Lord, Mgr.
Rings from \$100 to \$10,000 Trade-Mark Reg.

Bilingual Vote Rules

WASHINGTON (AP) — Four North Carolina counties will have to provide ballots and other election materials in the language of their American Indian residents, as well as in English.

The counties are Hoke and Robeson in the eastern part of the state, where Lumbee Indians live, and Jackson and Swain in the west, home of Cherokees.

The Justice Department issued proposed final regulations Wednesday requiring bilingual ballots and election materials in portions of 30 states.

No counties in South Carolina were included in the guidelines. The guidelines would become effective after a 30-day period for public comment. They would put into effect amendments to the Voting Rights Act passed by Congress last August.

The regulations are designed to expand participation in all types of elections for people who speak American Indian, Eskimo, Spanish, Chinese, Filipino, Japanese and Korean.

BONUS BUYS for Sharp Shoppers



DANELLE By
Daniels
WEDGE SANDALS

Regular \$11.88
\$16 & \$17

Crego's
307 EVANS ST., GREENVILLE, N.C.
OPEN DAILY 9:30 A.M. - 5:30 P.M.
PHONE 758-9159

Owned & Operated By Charles Hardee

Belk Tyler

PLANNING A LOOK TO LIVE WITH...

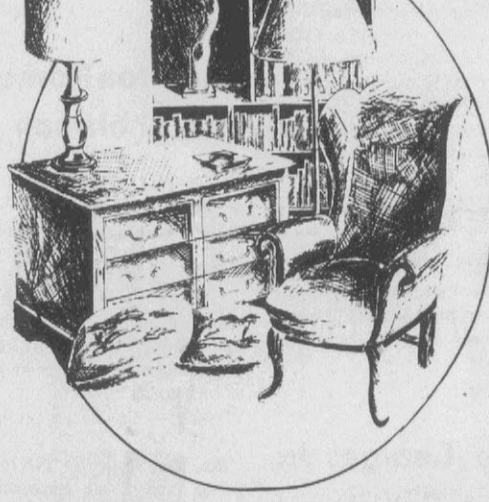

BELK TYLER INVITES YOU TO A FUN COURSE IN DO-IT-YOURSELF DECORATING



Join experienced interior consultant Jan Pinkston for a 2 class course to be held in your choice of sessions. Jan has 20 years experience in the decorating field. Learn in your first class: Color, How To Use It... Floor to Ceiling, Wall-To-Wall — Draperies, Carpet, Wall Paper, Paint and Furniture Arrangements.

In your second class... "Total Room Concept" — How to put it all together and a 30 minute question and answer period. The classes will be held at the American Legion Hall.

CONVENIENT COURSES TO MEET YOUR SCHEDULE

FIRST COURSE - AMERICAN LEGION HALL, ST. ANDREWS STREET
FIRST CLASS - 2 HOURS, WED., APRIL 28th, from 10 AM 'til 12 NOON
SECOND CLASS - 2 HOURS, WEDNESDAY, APRIL 28th, from 2 PM 'til 4 PM

SECOND COURSE - AMERICAN LEGION HALL, ST. ANDREWS STREET
FIRST CLASS - 2 HOURS, THURSDAY, APRIL 29th, from 10 AM 'til 12 NOON
SECOND CLASS - 2 HOURS, THURSDAY, APRIL 29th, from 2 PM 'til 4 PM

THIRD COURSE - AMERICAN LEGION HALL - ST. ANDREWS STREET
FIRST CLASS - 2 HOURS, WEDNESDAY, APRIL 28th, from 7 PM 'til 9 PM
SECOND CLASS - 2 HOURS, THURSDAY, APRIL 29th, from 7 PM 'til 9 PM

FOURTH COURSE - AMERICAN LEGION HALL, ST. ANDREWS STREET
FIRST CLASS - 2 HOURS, FRIDAY, APRIL 30th, from 10 AM 'til 12 NOON
SECOND CLASS - 2 HOURS, FRIDAY, APRIL 30th, from 2 PM 'til 4 PM

YOU'LL RECEIVE FOR REGISTRATION:

- KIRCSH'S "WINDOW BEAUTIFUL" (Retail for 1.50)
- "101 DECORATING IDEAS" (Retail for 1.00)
- SPRINGMAID'S PAMPHLET "MAKE IT WITH SHEETS"
- COFFEE BREAKS

OUR OWN DESIGNERS, MISS JAN HEIDENREICH AND MRS. EDNA COX WILL ASSIST MRS. PINKSTON.

Phone One Of Our Designers To Pre-Register!



Right: Mrs. Edna Cox
758-2176
EXT. 41

Left: Miss Jan Heidenreich
758-2176
Ext. 41



Announcing
We Are Changing Our Name From Greenville Jewelers & Music To...
Lord's
Greenville Jewelers
On The Downtown Mall
425 Evans St.
Phone 752-6753
Open Daily 9:30 - 5:30 — Sat. 9:30 - 6:00
Ruben Lord, Mgr.

Stock And Market Reports

RALEIGH (AP) (NCDA) — North Carolina egg prices were unchanged Wednesday. Weighted average prices for small lot sales of consumer grade A white eggs in cartons delivered to nearby retail stores were 61.13 cents per dozen for large, 54.13 for mediums and 41.11 for small.

RALEIGH (AP) (NCDA) — Corn prices were steady and soybeans weaker at leading North Carolina elevators Wednesday. No. 2 yellow shelled corn was quoted at 2.60 to 2.70, mostly 2.62 to 2.64 in the East and 2.70 to 2.80 in the Piedmont. No. 1 yellow soybeans were 4.57 to 4.78, mostly 4.74 to 4.77.

RALEIGH (AP) (NCDA) — Cotton quotations were lower on the Charlotte market Wednesday. Strict low middling 1-16 inch was quoted at 58.75 per hundred pounds.

RALEIGH (AP) (NCDA) — Livestock sales Tuesday included 673 head of cattle and 541 head of hogs sold in Rocky Mount.

Slaughter cows utility and commercial 26-33.00; vealers (150-240 lbs) good 41.50-46.00; slaughter calves (325-550 lbs) good 35.00-40.50; slaughter steers (800 lbs and up) good 39.00-41.75; slaughter heifers (700 lbs and up) good 33.00-40.00; feeder steers (300-600 lbs) 36.50-41.20; feeder heifers (500 lbs and up) good 33.75; market hogs (180-240 lbs) 48.20-49.40; sows (300-600 lbs) 41.30-41.90.

RALEIGH (AP) (NCDA) — Graded feeder pig auctions included 1,091 head sold at Norwood. U.S. No. 1 and 2: 40-50 lbs 120.25, 50-60 lbs 110.00, 60-70 lbs 101.00, 70-80 lbs 90.50; U.S. No. 3: 40-50 lbs 115.75, 50-60 lbs 100.25, 60-70 lbs 87.75.

Following are selected 11 a.m. stock market quotations:

Burroughs	107
United Telecommunications Pfd.	20 1/4
Heublein	50 1/4
Jeff Pilot	27 1/2
Wicks	13 1/2
Wachovia Realty	18 1/4
Eckerd	14 1/2
Central Soya	7 1/2
Hardees	7 1/2
Intregon	20 1/2
Fieldcrest	16 1/2
Hatters Income	13 1/2
Yepco	13 1/2
OVER THE COUNTERS	
Combined Insurance	9 1/4-9 1/2
Franklin Life	20 1/4-20 3/4
NCNB	11 1/4-12 1/4
Piedmont Air	4 1/2-5 1/4
Little Mint	3 1/2-3 1/4
Corner Homes	3 1/4-3 1/2
Guardian Corp.	2 1/4-3 1/4
Planters Bank	1 1/2-1 1/4
Daniel International Corp.	23 1/4-24

RALEIGH (AP)—(NCDA) — The trend on the North Carolina hog market was steady to 50 cents lower today. Wilson 47.50-48.50; High Falls 46.50-47.50; Rocky Mount 48.50-48.50; Clinton, Fayetteville, Dunn, Elizabethtown, Pink Hill, Pine Level, Chadbourne, Ayden, Laurinburg, Benson, 48.50; Kinston 48.00-49.00; Tarboro and Bethel 45.50-46.00; Salisbury 47.00.

RALEIGH (AP)—(NCDA) — The trend on the North Carolina f.o.b. dock broiler market was weaker for next week's trading, with supplies adequate, demand good, weights desirable.

The North Carolina dock weighted average price is 43.41 cents per pound this week for small purchases of sized plant grade broilers to be picked up at processing plants. Estimated slaughter today was 1,146,000.

NEW YORK (AP) — Midday stocks

Abbl Lab	High	Low	Last
Alcoa	46	46	46
AliaChal	24	24	24
Alcoa	52 1/4	52 1/4	52 1/4
Am AirLin	10 1/2	10 1/2	10 1/2

The Meeting Place

THURSDAY
7:00-8:00 p.m.—Game day at Woman's Club
8:30 p.m.—Jaycees meet at Riverside Restaurant
9:30 p.m.—Exchange Club meets
7:00 p.m.—Winterville Kiwanis Club meets at community bldg.
8:00 p.m.—Chapter 1308 of the Women of the Moose
8:00 p.m.—VFW Auxiliary meets at Post Home

FRIDAY
7:30 p.m.—Redmen meet
8:00 p.m.—Alcoholics Anonymous meets at Ayden Christian Church. Telephone 746-6242 or 746-3323

CORRECTION

The following was incorrectly stated in the Wednesday, April 21st Edition of The Daily Reflector. It should have read as follows:

LADY SCOT

TISSUE 2 89c

2-Roll Packs

HARRIS

SUPER MARKETS, INC.

"Where Shopping Is A Pleasure"

Garner Is Elected N.C. Grand Master

RALEIGH — Leslie H. Garner of Greenville, was elected Grand Master of Masons in North Carolina at the annual Stated Communication of the Grand Lodge of North Carolina held here yesterday.

three air medals for 51 missions flown in the European Theater of Operations. After his discharge from the Air Force as a technical sergeant, Garner served as warehouse manager for Ormond Wholesale Co. here until 1951 when he and J. T. Manning and Thurston Wynne organized Garner-Wynne-Manning Inc.

Masters and was appointed to the Grand Lodge line of officers in 1969. He is a 33rd Degree Mason and a member of the York Rite and Scottish Rite Masonic Bodies. He is also past president of the Pitt County Shrine Club.

FEELING COOPED UP IN YOUR PRESENT HOME?



Is your family still growing? Did a promotion make it possible for you to move up? Would you like more security for the future? If you answered "yes" to any of these questions, you're in the market for a new home. Call a REALTOR®, quick. REALTORS® are real estate professionals. They belong to a professional organization and follow a professional Code of Ethics. You can depend on a REALTOR® to help you find exactly what you need.

Greenville-Pitt County Board
REALTOR® Of Realtors

THE LAND
an investment for all times

PRIVATE PROPERTY

APRIL 18 to 24, 1976

Obituaries

Caldwell
Mr. Leonard Wilson and Mrs. Anice Chance Wilson were listed in the obituary of Mrs. Carolyn Caldwell as grandparents of the deceased. They are her parents.

Gaskins
Mr. Jason Gaskins, 70, died at Craven County Hospital, New Bern, this morning.

Funeral services will be conducted at 3:30 Friday afternoon at the Wilkerson Funeral Chapel by the Rev. Leon Page, pastor of West Craven Free Will Baptist Church. Burial will be in Celestial Memorial Gardens, Vanceboro.

Mr. Gaskins spent all his life in the Ernul community and was a member of Macedonia Free Will Baptist Church.

He is survived by his wife, Mrs. Emmie Chase Gaskins; a son, Milton M. Gaskins of Vanceboro; two daughters, Mrs. Gilly G. Jackson of Jacksonville, and Mrs. Donald Cuthrell of New Bern; a sister, Mrs. Donald Lyttle of Vanceboro; seven grandchildren and one great grandchild.

The family will receive friends at the funeral home from seven to nine o'clock tonight.

Green

STOKES — Mr. Robert Lee Green died Saturday in Wilson. Funeral services will be held

Saturday at 2 p.m. at Burning Bush Holiness Church by his pastor, Elder Lillie Boyd. Burial will be in Brown Hill Cemetery.

Surviving him are his wife, Mrs. Sallie Barnes Green of Stokes; four daughters, Mrs. Magdalene Hopkins of Stokes, Mrs. Bettie Cooper, Mrs. Rachel Carroll, and Mrs. Rosa Green, all of Greenville; a son, John R. Green of New York; four sisters, Mrs. Rubelle Skipper, Mrs. Annie Harris, and Mrs. Maggie Moore, all of Greenville, and Mrs. Rosa Lee Sesson of Baltimore, Md.; a brother, Cecil Green of Norfolk, Va.; 12 grandchildren; and one great grandchild.

Family visitation will be at Phillips Brothers Mortuary Friday from 8 to 9 p.m.

Harris

Mr. Benjamin Harris died at his home 1202 Farmville Blvd. Wednesday night. He was the husband of Mrs. Maggie Harris. Funeral arrangements are incomplete at Flanagan and Parker Funeral Home.

PWP Programs Are Announced

"How to Raise Kids in Your Spare Time" will be the topic of a discussion moderated by Alice P. Carroll, Early Childhood Specialist with the Tideland Mental Health Center, Friday, at 8 p.m. at St. Paul's Episcopal Church, 401 E. Fourth Street.

Sunday there will be family skating for PWPers at Sportsworld beginning at 1 p.m. and family bowling at Hillcrest Lanes from 4 to 6 p.m.

For further information about PWP, one may call Dave Knowles at 758-9954 after 6 p.m.

Mathematician At Nevada Meet

Dr. Gary Richardson, associate professor of mathematics at East Carolina University, is attending the Western Sectional meeting of the American Mathematical Society at the University of Nevada in Reno.

He is to report on his research project, "Embedding in Topological Vector Spaces."

Dr. Richardson will also speak at the Conference on Convergence Spaces being held in conjunction with the AMS meeting. He will present results of his own research, and read a paper for Roman Fric of Czechoslovakia who is unable to attend the conference.

Before arriving at the Reno campus, Dr. Richardson stopped at the University of Arkansas where he spoke on locally compact convergence spaces.

No Charges In Car Collision

No charges were reported following investigation of a 9:57 p.m. collision at the intersection of Farmville Boulevard and Memorial Drive yesterday involving cars driven by Kenneth Ray McLawhorn of Route 2, Greenville and James Allen Gorham of Route 1, Fountain. Police estimated damage from the collision at \$200 to the McLawhorn car and \$400 to the Gorham vehicle. No injuries were reported.

Singleton Named Pitt Chairman

Lt. Gov. Jim Hunt, Democratic candidate for Governor, has named Louis Singleton of Greenville as chairman of his campaign in Pitt County.

"We are running a people's campaign for Governor," Hunt said, "and it is people like Louis Singleton who are going to make us successful."

Singleton is a Greenville lawyer. Hunt said Singleton, "is a fine person and I am especially proud and pleased that he will play this key role in my campaign in Pitt County. I know he will do an outstanding job."

A Wilson native, Hunt was elected North Carolina's first full-time lieutenant governor in 1972.

CHURCH SALE

St. James United Methodist Church will hold a yard sale and bake sale Saturday from 8 a.m. to 12 noon at 2000 E. 6th St.

WOMEN'S SHOE SALE 450 Pairs On Sale

1/2 OFF

• Dress • Casual • Work

White — Bone — Red — Navy — Black — Yellow — Green — Tan — Brown — Camel — Multi.

Quality Shoes Brand Names You Know

Larry's SHOE STORE

• Quality • Fit • Service

At 5 Points, Downtown Greenville
Open Daily 9 A.M. - 6 P.M.

Hunter
FARMVILLE — Miss Margie Dean Hunter died at Medical College Hospital in Richmond, Va. Wednesday. She was the daughter of Mrs. Roberta Hunter. Funeral arrangements are incomplete at Flanagan and Parker Funeral Home.

Lacewell
Mrs. Mary Lee Lacewell died Wednesday in Washington County Hospital in Plymouth. She was the sister of Miss Katie Brown of Greenville. Funeral arrangements are incomplete at Flanagan and Parker Funeral Home.

Parker
Mrs. Annie Clemons Parker died at her home 204 N. Hudson St. Tuesday. Funeral services will be conducted Sunday at 1 p.m. at St. Peter Baptist Church with Rev. N. H. Harris officiating. Burial will be in the Brown Hill Cemetery.

Mrs. Parker was a native of Pitt County and spent her life in the St. Peter and Greenville communities. She was a member of St. Peter Baptist Church.

Surviving are three daughters, Mrs. Lubertha Dixon of the home, Mrs. Celia McClinton of Greenville and Mrs. Martha Sheppard of Greenville; four sisters, Mrs. Robert Ann Hemby, Miss Mary Clemons, of Greenville, Miss Bertha Clemons of New York and Mrs. Joanna Stator of Newark, N. J.; three brothers Lemuel Clemons of Greenville, Joseph Clemons of Baltimore, and James Clemons of Bridgeport, Conn.; six grandchildren; and three great grandchildren.

The body will be at Flanagan and Parker until the time of the service. Family visitation will be Saturday from 7 to 8 p.m.

Trimble

Mrs. Annie Flood Trimble of 1200 Myrtle Avenue here died Wednesday in Pitt Memorial Hospital. She was the wife of Johnnie Trimble. Funeral arrangements are incomplete at Phillips Brothers Mortuary.



LESLIE H. GARNER

Garner is secretary-treasurer and general manager of Garner-Wynne-Manning Inc. of Greenville and a director of Big Value Discount Drugs, Inc. and All-purpose Cabinet Shop, Inc. A native of Newport in Carteret County, Garner graduated from Greenville High School and served in the U. S. Army Air Force for 27 months during World War II, receiving the Distinguished Flying Cross and

Science Club Visits Campus

Thirty-one members of the Farmville Central High School Science Club visited the East Carolina University Department of Biology Wednesday.

The students, accompanied by their club advisor, Grady Bailey, toured the electron microscope laboratories, the greenhouse and the small animal facilities.

PEANUTS TO YOU!
SHELLED OR UNSHELLED
KEEL PEANUT COMPANY
Memorial Drive adjacent to Bateman's Animal Clinic.

Wickes Lumber WAREHOUSE CLEARANCE Sale

NOW IN PROGRESS All In-Stock Whirlpool & Frigidaire Appliances AT OR BELOW WHOLESALE WHILE THEY LAST!

Just Say CHARGE IT!

125 W. Greenville Blvd. Greenville, N.C. Phone 756-7144 Monday-Friday 8:00 A.M.-5:30 P.M. Saturday 8:00 A.M.-4 P.M.

Hwy. 264 By-Pass Farmville, N.C. Phone 753-3111 Monday-Friday 8:00 A.M.-5:00 P.M. Saturday 8:00 A.M.-3 P.M.

Memories: Mets Bobble It Away Pirates Slump, End Up Second In S.C. Golf

By HERSCHEL NISSENSON
AP Sports Writer

The New York Mets were hit or thrown at so many times during Tuesday night's bean-ball war with the St. Louis Cardinals that they shied away from anything resembling a baseball Wednesday.

As a result of two botched pop flies, one butchered ball in left field and a couple of wild pitches they brought back memories of the fledgling 1962 Mets and dropped a 7-4 comedy of errors to the Cardinals.

Elsewhere in the National League, the Atlanta Braves shut out the San Francisco Giants 3-0 with Andy Messersmith notching a million-dollar save; the Philadelphia Phillies blanked the Pittsburgh Pirates 3-0; the Cincinnati Reds edged the San Diego Padres 5-4; the Houston Astros nipped the Los Angeles Dodgers 1-0 in 16 innings, and the Montreal Expos led the Chicago Cubs 11-3 when darkness forced a suspension

after six innings. The game will be completed today.

The fun in St. Louis began in the Cards' second. Ted Simmons doubled and Mickey Lolich wild pitched him to third. Simmons headed for home when catcher Jerry Grote had trouble following the bouncing ball and scored when Grote's high throw glanced off Lolich's glove at the plate. Lolich then fanned Mike Anderson, but the third strike was another wild pitch and Anderson reached safely.

That one didn't hurt and, although St. Louis picked up a run in the fourth when Simmons scored from first as left fielder Benny Ayala played butcher-boy with Reggie Smith's single, the Mets led 4-2 in the sixth, with Lolich contributing a pair of key singles. But Vic Harris opened the St. Louis sixth with a catchable pop fly that fell between first baseman Ed Kranepool and

second baseman Felix Millan for a gift double. Lolich retired the next two batters, but Smith, the fourth out, tied the score with a home run.

Anderson, not one to look a gift horse in the mouth, was credited with a double when his pop-up fell among Ayala, centerfielder Bruce Boisclair and shortstop Mike Phillips. Ron Fairly singled Anderson home and scored on Don Kessinger's double.

The Cardinals, however, didn't take kindly to being upstaged laugh-wise in their own ballpark. So when winning pitcher Harry Rasmussen rapped an apparent double, scoring Kessinger, he was called out for failing to touch first base.

Braves 3, Giants 0
Dick Ruthven and Messersmith combined on a six-hit shut-out. Ruthven, who singled home the final run in a three-run second inning after Darrel Chan-

ey's two-run single, blanked the Giants for seven innings but was lifted in the eighth after a leadoff single and a walk.

Messersmith, signed for \$1 million as a free agent, got Chris Spier to ground into a double play and Ken Reitz bounced out to end the threat.

Phillies 3, Pirates 0
Mike Schmidt belted his seventh home run in the last four games and Tom Underwood and Tug McGraw combined to limit Pittsburgh to seven hits. The Phils got the only run they needed in the first inning on Jay Johnstone's double and Greg Luzinski's single. Schmidt homered in the eighth, but was upset because he has struck out 14 times in 37 at-bats.

"I'm an easy out between home runs and that's not good," he said. "I'm hitting a lot of home runs right now, but I'm still not swinging the bat good."

Reds 5, Padres 4
Ken Griffey's two-run single triggered a five-run third inning for Cincinnati. Griffey stole second and scored on a

single by Tony Perez. Singles by George Foster and Cesar Geronimo produced the fourth run and the fifth scored on shortstop Hector Torres' throwing error. Mike Ivie drove in three San Diego runs with a double and single.

Astros 1, Dodgers 0
Jose Cruz' single with two out in the 16th inning scored Larry Milbourne from second base. The winning hit came off reliever Stan Wall after Milbourne had singled and stolen second base and Jerry Davanon was intentionally walked. The game started as a pitching duel between Houston's J.R. Richard, who went 10 innings, and Tommy John of the Dodgers, who worked seven.

Expos 11, Cubs 3
Mike Jorgensen and Jerry White homered for Montreal while Tim Lincecum had a single, double and triple and drove in two runs. Before its suspension, the game started 15 minutes late and was halted four times by rain. Jose Cardenal and Steve Swisher had Chicago home runs.

By WILLIE PATRICK
Special To The Reflector

FLORENCE, S.C. — Authentic sporting event analysts often speak of a fine line distinguishing a winning team and one that finishes somewhere else.

The speech remains constant in nature, though the names and sport involved usually differ from situation to situation. You've probably heard it all before, especially the clinching comment:

"A champion turns in his best performance in the clutch, when the team needs it the most."

Such was the case with Furman here Wednesday afternoon in the closing round of the

Southern Conference golf tournament at the Country Club of South Carolina. The Paladins fired a 373 for a three-day 1-119, good enough for their third straight title.

East Carolina University skied to 391, its worst single-day total of the event, to finish at 1,140. It was third straight bridesmaid finish for the Pirates.

"Furman got help when it was needed," said Pirate Coach Mac McLendon. "When you put six people on the all-conference team, you have to be doing something right."

Included in that sixsome was Ken Exell's three-day 221, good enough for tourney medalist

honors. The Pirates reaped some individual honors as well:

Rob Welton carded a 75-71-78-224 to finish alone in second place, while teammates Keith Hiller (75-74-78-227) and Steve Ridge (77-72-79-228) tied for sixth and eighth, respectively.

Appalachian State finished a distant third, in team totals with 1,168, followed by Richmond, 1,181; William & Mary 1,197; VMI 1,217; Citadel 1,222 and Davidson 1,228.

Rounding out the individual scoring for the Pirates were Mike Buckmaster (74-81-81-236), Frank Acker (78-76-80-234) Trip Boinest (73-84-76-233; and Phil Bell (81-82-81-224).

Injuries Proved Aid To Alston's Efforts

Many times in the field of athletics, it takes injuries to key performers to give one a chance to prove himself as a starter. And when one gets his chance, it sometimes turns out that he is better than his predecessors. Calvin Alston falls into this mold.

During the indoor season, Alston was the fourth best sprinter on the East Carolina University track team (three others above him qualified for the nationals, but he failed to do so in the 60 yard dash). Larry Austin was injured in the indoor conference meet, while Donnie Mack and Carter Suggs were injured in the first two outdoor meets. This gave Alston the

chance he needed and he took advantage of it.

The diminutive freshman from Henderson starred in the South Carolina State-Record Relays. Running against very strong competition, Alston finished third and turned in a fine time of 21.0. This time, when converted to yards broke the East Carolina varsity mark which was 21.1 (conversion factor from 200 meters to 220 yards is to add 1.8 second). That's not bad for the man who was considered to be the fourth best sprinter on the team.

"I knew I could run the 200 meters of 220 yards in a very fast time. I'm a bit slow on the turn but I can really turn it on down the straightaway. I believe I can run a 20.8 or 20.9 before the year is out. I've already qualified for the nationals."

When asked about how he got his big chance, Alston said that "I got my chance when the other three were injured, which is a bad way to get it, but I'm glad I took advantage of it."

Being short in stature (Alston is listed at 5-8 but looks smaller) seems to be no problem for Alston. He notes that "it helps me to be short because the other guys think I'm too short to outrun them, but I hit the straightaway I can move on out."

In high school, at Vance

County High, Alston lettered in track three times and twice in football. He ran a 9.6 in the 100 yard dash while on the scholastic scene and a 21.6 in the 200 meters. These are outstanding for a high school athlete, but he has since improved to where he would be most unhappy with such clockings now.

County High, Alston lettered in track three times and twice in football. He ran a 9.6 in the 100 yard dash while on the scholastic scene and a 21.6 in the 200 meters. These are outstanding for a high school athlete, but he has since improved to where he would be most unhappy with such clockings now.

Track coach Bill Carson had much praise for his frosh sprint sensation.

"Calvin has sure been a pleasant surprise this season," said Carson. "He came right in when everybody else was injured and picked up a varsity record. He has been one man on this team I could depend on to score in every meet."

Alston has high aspirations for East Carolina in the conference meet that will be held in two weeks. The Pirates have finished second nine times and third once in the last ten years and William & Mary has won every one.

I really think we can win that conference meet this season. We have the personnel to do it. We will have to have everybody healthy. But one thing that is gonna happen is that I'm gonna work hard to win that 200. I believe I can win it."

If the Pirates are to win the conference championship, it will take hard work and determination, such as that shown by Alton. As for Alston, the hard work has paid off fine dividends so far and could very well continue through the conference meet.

Ramsey Angered After Defeat

By The Associated Press
Jack Ramsay will tell you that the Boston Celtics are one of the most physical clubs in the National Basketball Association — and his Buffalo Braves have the marks to prove it.

"I would like to have seen better control by the officials," said Ramsay after losing a 107-98 decision in the opener of the NBA's Eastern semifinal playoffs Wednesday night. "It was a very physical, aggressive, holding game."

One of the most physical of the Celtics, as usual, was Dave Cowens, who scored 30 points despite an injured heel.

The Celtics were up to their old roughhouse tricks, apparently undisturbed by a 10-day layoff.

In other NBA playoff action Wednesday night, the Washington Bullets defeated the Cleveland Cavaliers 109-98 and tied their best-of-seven Eastern semifinal series at two games apiece.

The Cavaliers entertain Washington in tonight's action while the Golden State Warriors, leading 1-0 in their Western semifinals, host the Detroit Pistons.

The Phoenix Suns, holding a 3-1 lead in the other Western semifinal, won't get a chance to nail down that series until Sunday when they meet the Super-Sonics in Seattle.

JoJo White added 27 points to the Boston cause while John Havlicek contributed 22 as Boston opened its bid for a 13th NBA title. Cowens, playing all but the final seconds, grabbed 17 rebounds, had seven assists and five steals in another brilliant effort.

White had eight assists and three steals to go with his scoring.

Netters In 8-1 Victory

The Greenville women's tennis team romped to an 8-1 victory over Goldsboro in an East Carolina Tennis Association match yesterday.

Greenville won all three of the doubles matches, and took five of the six singles events.

Summary:
Frances Cain (Gr) defeated Sissy Well, 6-3, 6-0.
Carlie Wills (Gr) defeated Carol Kennedy, 6-4, 6-2.
Mary Edmundson (Go) defeated Nancy Powell, 6-7, 6-4, 7-4.
Becky McDonald (Gr) defeated Sally Irb, 6-1, 6-2.
Lib Proctor (Gr) defeated Rosemary Sigg, 6-4, 6-2.
Rae Daniel (Gr) defeated Sandra Kerr, 6-0, 6-2.
Cain-Barbara Close (Gr) defeated W.L. Edmundson, 4-1, 7-4.
Wills-Powell (Gr) defeated Kennedy-Lya Smith, 6-7, 7-4, default.
McDonald-Proctor (Gr) defeated Irb-Kerr, score not available.

Tigerettes Take Game

WILLIAMSTON — The Williamston girls' softball team romped to a 12-3 victory over Edenton yesterday.

Williamston scored a trio of runs in the first inning and matched that in the second. They then added two runs in each of the fourth, fifth and sixth innings. All three Edenton runs came in the top of the seventh.

Ferinda Spruill got credit for the victory on the mound. She picked up two hits, also, including a two-run homer in the sixth. Valeria Barnhill also had two hits, including a three-run homer in the first. Terry Hopkins added two more hits for the Tigerettes. Holly had two to lead Edenton.

Williamston is now 5-1 overall and 3-0 in conference play. The Tigerettes travel to Bear Grass on Tuesday.

Ed'ton 000 000 3-3
Will'ton 330 222 x-12

Today's Sports
Baseball
Pembroke State at East Carolina (3 p.m.)
Gaylord Perry Tournament at Williamston
North Lenoir at North Pitt (4 p.m.)
Conley at Greene Central (7:30 p.m.)
Softball
North Lenoir at Conley
Ayden-Griffon at Rose (3:30 p.m.)
Tennis
NCAIAW Tournament at North Carolina
Friday's Sports
Baseball
Farmville Central at Ayden-Griffon (8 p.m.)
E. B. Aycock at Nash Central (4 p.m.)
Greene Central at C. B. Aycock (7:30 p.m.)
Jamesville at Mantoo
Gaylord Perry Tournament at Williamston
North Pitt at Southern Nash (4 p.m.)
Conley at North Lenoir (4 p.m.)
Bear Grass at Aurora
Track
East Carolina at Penn Relays
Rose girls at Farmville Central
Pitt County Meet at Rose
Tennis
Northern Nash at Rose (3 p.m.)
NCAIAW Tournament at North Carolina



Delicious Rib-eye Steaks
Choice New York Strip
Filet Mignon
Alaskan King Crab Legs
Lobster Tails
Gourmet Salad Bar

Steaks Cooked Over Live Charcoals.
Finest Wines and Champagnes

400 St. Andrews St.
756-1212

Mon.-Sat. 6 P.M.-10:30 P.M.
Open Sundays 6-10 P.M.

WE CATER TO PRIVATE PARTIES
Gift Certificates Available

UNDER NEW MANAGEMENT

See Joe Ramey-Paul Grady
For The Finest In
AUTOMOTIVE SERVICE
And
Randolph Radford
For
**EXPERT TUNE-UPS
AND MINOR REPAIRS**
ALSO
Fine Texaco
**GASOLINE AND
AUTOMOTIVE PRODUCTS**
At Reasonable Prices
Memorial Drive
TEXACO
Beside Carolina Dairies
Hours: 7 A.M. 'Til 8 P.M. Mon.-Sat.

Baby Jags Get Victory

SNOW HILL—The Farmville Central "B" baseball team took a 9-4 victory over Snow Hill Middle School's ninth graders yesterday.

Phillip Gordon was the winning pitcher for the Baby Jaguars, now 3-3.

Ted Johnson led the Farmville hitting with a three-run double in the six-run third inning. Farmville goes to North Pitt on Monday.

Baby Jags Get Victory

SNOW HILL—The Farmville Central "B" baseball team took a 9-4 victory over Snow Hill Middle School's ninth graders yesterday.

Phillip Gordon was the winning pitcher for the Baby Jaguars, now 3-3.

Ted Johnson led the Farmville hitting with a three-run double in the six-run third inning. Farmville goes to North Pitt on Monday.

If you're looking for the best value in
HOME-OWNERS Insurance
you'll find it at State Farm

Give me a call today. You'll discover what's made State Farm the number one homeowners insurer in the world.



Bill McDonald

East 10th St. Ext.
Phone 752-6680
Greenville, N.C.

Like a good neighbor,
State Farm is there.

For Campers & Vans Pickups, Panels, RV's

SALE

'TRACKER LT' TIRES

\$34

G78-15 TT with trade
Reg. Price \$37.50

Size & Type	Load Range	PLY	Regular Price With Trade	Sale Price With Trade
E78-14 TBL	C	6	\$40.05	\$36.05
G78-15 TBL	C	6	\$41.40	\$37.25
H78-15 TBL	C	6	\$52.50	\$47.25
L78-16 TT	D	8	\$62.45	\$56.20

Plus \$3.12 to \$4.15 F.E.T., depending on size.

SALE ENDS SAT. NIGHT

8 Ways to Buy

- Cash • Goodyear Revolving Charge
- Our Own Customer Credit Plan
- Master Charge • BankAmericard
- American Express Money Card
- Carte Blanche • Diners Club

Lube and Oil Change

\$4.88

Up to 5 qts. of major brand 10-30 grade oil.

Front-End Alignment

\$11.88

Any U.S. made car with extra 4 wheel drive.

Engine Tune-Up

\$36.88

\$28.88 for 4 cyl. \$2 for air cond.

See Your Independent Dealer For His Price. Prices As Shown At Goodyear Service Stores.



GOODYEAR SERVICE STORES

729 Dickinson Ave. Open Mon.-Fri. 7:30 to 6, Sat. 7:30 to 5, Phone 752-4417
J. F. Forehand, Mgr.

AUTO REPAIRS? GOODYEAR'S SERVICE DEPT. OPEN SAT TIL 5 P.M.

Palmer Turns In 5-1 Victory

By KEN RAPPOPORT
AP Sports Writer
For eight innings, the Baltimore Orioles had the California Angels in the hand of their pitcher, Jim Palmer.

Then Jim Palmer needed a hand himself in the ninth. "I usually get my second wind, but tonight I didn't," said Baltimore's Cy Young Award winner after helping the Orioles whip the Angels 5-1 Wednesday night.

The lean right-hander was working on a gorgeous one-hitter before running into a stormy ninth. Palmer gave up a walk to Rusty Torres, a single to Jerry Remy and a sacrifice fly to Bill Melton to lose his shutout. And when he walked another batter, Palmer was replaced by Dyer Miller.

"I didn't ask to come out," Palmer said. "But I knew how I felt. I had trouble closing my hand because my forearm had tightened up."

Manager Earl Weaver doesn't usually like to take Palmer out of a game, but he obviously didn't have a choice Wednesday night in Anaheim.

"He'll give you three good games every four times out," said Weaver. "He just completely ran out of gas tonight."

In other American League games, the Detroit Tigers beat the Oakland A's 7-3 and the New York Yankees defeated the Chicago White Sox 10-7. Two games were rained out — Kansas City at Milwaukee and Texas at Cleveland.

Palmer was working on a no-hitter when Bruce Bochte lined a single to center leading off the fifth inning.

"It was a mistake on my part," said Palmer, 3-1, "but he still had to hit it. It was a hanging curve and I was indecisive on how to throw it."

Palmer was then untouchable until the troublesome ninth.

Baltimore, which had dropped six of its previous seven games, jumped on loser Don Kirkwood, 0-2, for three runs in the first inning, capped by Ken Singleton's homer, and added two more in the second.

The Orioles managed seven hits, including the homer and single by Singleton, two doubles by Al Bumbry and a double and single by Paul Blair.

Tigers 7, A's 3
Willie Horton and Rusty Staub hit two-run homers to lead Detroit over Oakland. Horton connected in the first inning and Staub in the sixth. Both shots came off losing pitcher

Mike Torrez, 1-3.
The Tigers scored three runs in the first and four more when nine batters went to the plate in the sixth. A single by rookie Jerry Manuel drove in the other two runs in the sixth.

Yankees 10, White Sox 7
Chris Chambliss and Mickey Rivers drove in three runs apiece and rookie Willie Randolph collected four straight hits to lead New York past Chicago. Rudy May, backed by a 17-hit

attack, allowed only two hits over the first seven innings but yielded a two-run homer to Pete Varney in the eighth and was chased by Jack Brohamer's two-run triple in the ninth.

National Hockey Loop Prexy To Be Arraigned

OTTAWA (AP) — National Hockey League President Clarence Campbell was scheduled to be arraigned on conspiracy charges today with three other former associates in Sky Shops Exports, Ltd., and Liberal Senator Louis Giguere.

The others to be arraigned were former Sky Shops Board Chairman Louis Lapointe; former Executive Vice President Gordon G. Brown, and former Treasurer James Lavery.

At the same time, a Montreal judge will set a date for a special closed hearing to deter-

mine whether charges of influence peddling should be laid against Sen. Giguere.

The charges stem from an investigation into the 1972 extension of the lease on a Sky Shops duty-free store at the airport in Dorval, Que. The lease had been scheduled to lapse in 1975, but was extended to 1980 — without acceptance of competitive bidding — in June of 1972 before Giguere made a purchase of 5,000 shares of Sky Shops stock at \$1 per share.

On that day, June 9, 1972, Gi-

guere sold his stock to Lavery for \$15 per share and made a \$95,000 profit.

It has been alleged that the transaction took place in return for Giguere's having used influence to get the company its lease extended without competitive bidding.

The senator last November denied any wrongdoing, saying he simply exercised an option offered him in 1970 by Lapointe while they played golf in Florida.

The five were to appear in the court at the city police station to hear the charges read. The alleged offense carries a maximum penalty of five years in prison.

Campbell, who was president of the firm when the deal took place, received a unanimous vote of confidence Wednesday from the NHL's Board of Governors.

"We are unanimous in our support of Mr. Campbell and stand behind him 100 per cent," said a prepared statement released by Chicago Black Hawks President William Wirtz, who also heads the board.

Spurs Nip Nets, Pull Even In Series, 3-3

By STEVEN M. EAMES
Associated Press Writer
SAN ANTONIO, Tex. (AP)—Bob Bass, coach of the San Antonio Spurs, says he was surprised that the New York Nets withheld forward Rich Jones from Wednesday night's American Basketball Association semifinal playoff game.

But "it was their judgment," he said.

Before the game, which the Spurs won 106-105 to even the series at 3-3, Nets Coach Kevin Loughery decided that Jones should not play because of "conditions caused by certain officials of the Spurs and the local media."

Jones was involved in a brawl during the fourth game of the series here last Sunday. After the fight, Spurs General

Manager John Begzos called Jones "trash" and Bass said Jones was "a cheap shot artist."

"The man is very upset," Loughery said. "Personally, I couldn't put up with this."

"It's just like a nightmare," said Jones. "I can't even believe this. It's like being on another planet. All I want to do is get out of this place."

Jones played for the Spurs for two seasons and maintains an off-season home here. But he said Wednesday night, "I'm going to sell it as quick as I can."

"It was my decision. I made it on my own," said Loughery. "He wants to play, but I don't think he's in any frame of mind to play."

In the other ABA playoff

game Wednesday night, Denver beat Kentucky 108-106 to even their best-of-seven series at two victories each.

The New York coach said he was concerned about Jones' safety, but later, when questioned by newsmen, Loughery said Jones probably would have been in no danger.

The brawl took place in Sunday's game which New York won 110-108.

Spurs forward Larry Kenon sank two free throws with three seconds left to give the Spurs the victory Wednesday and even the series at 3-3.

Sunday's game in New York will determine which team faces the winner of a Denver-Kentucky series in the final playoff.

The Spurs' high scorer Wednesday was George Gervin with 37 points. Julius Erving paced the Nets with 41, 31 in the second half when he led a Nets' comeback.

Nuggets 108, Colonels 106
Chuck Williams' 24-foot jump shot at the buzzer gave Denver its victory over Kentucky and tied the series. The Nuggets' Ralph Simpson scored 26 points to lead all scorers, and Williams added 20. Artis Gilmore had 22 points for Kentucky, which led by sizable margins several times in the first half.

GOOD SHOT
NEW YORK (UPI) — Rick Barry, currently with the Golden State Warriors, is the only player ever to win the scoring championship in both the National and American Basketball Associations.

Sudden Death For Two Teams

By The Associated Press
The Atlantic Coast Conference championship baseball tournament opens Thursday with three sudden-death games.

They are arranged so that no team plays at home.

An afternoon doubleheader will be played at Chapel Hill, N.C.: North Carolina State (6-6 in the league) vs. Wake Forest (5-7), and then Maryland (8-4) vs. Duke (1-11).

North Carolina (8-4) will meet Virginia (4-8) in Raleigh.

The Clemson Tigers have a first-round bye as the regular-season leader at 10-2. The three survivors will join Clemson on the Tigers' home field Friday

for three days of double-elimination play.

The winner of the tournament will represent the ACC in NCAA district play leading to the College World Series in Omaha.

The tournament has been played only three years, and North Carolina State has won each time. Clemson was the regular-season leader each year but faltered in the tournament.

In the Friday afternoon doubleheader, Clemson will play the N.C. State-Wake Forest winner, and then the other two Thursday survivors will meet.

Three Must Win To Stay Alive

By FRANK BROWN
AP Sports Writer
The best-of-seven National Hockey League quarter-final playoffs have become a best-of-one series for the Toronto Maple Leafs, Buffalo Sabres and Los Angeles Kings, all of whom must win tonight to stay alive in Stanley Cup competition.

Toronto and Los Angeles at least will have the home ice advantage in their attempt to stave off an onrushing summer vacation. The Maple Leafs won both of their home games against defending champion Philadelphia to even the series at 2-2 before the Flyers took Tuesday night's contest 7-1. The Kings split their home games against the Bruins, but won once in Boston.

The Sabres, who show a dismal 3-12 record in playoff games on the road since they entered the league in 1970-71, will have to hope the law of averages is with them against the Islanders. New York, which lost the first two games in Buffalo, has won the last three and can clinch a semifinal berth tonight at Uniondale, N.Y.

If the Flyers, Bruins and Islanders complete quarter-final play tonight, they would join the Montreal Canadiens — who swept past Chicago in four games — in a semifinal round which could begin as early as Saturday. The Canadiens would host the Islanders and the Bruins would meet the Flyers in Philadelphia.

Three teams will do their best to keep that from happening tonight. "When it comes down to a situation like this, the bloody home ice advantage doesn't make that much of a difference," insisted Sabres General Manager Punch Imlach. "It's who wants to win the most. If

we want it most, we have the horses to win."

But they'll be in for a struggle against the Islanders, whose aggressive hitting game has slowed down the free-skating Buffalo forwards. "For a team like ours, whose game is hitting, we're more accustomed to it," said New York defenseman Denis Potvin. "They don't have everyone who hits, just a few. We've got everybody who hits."

Hitting also will be the focal point of Boston's assault on a semifinal berth. "When you intimidate a team, you have the advantage and it's a big advantage," says Bruins wing Hank Nowak. "They (the Kings) are giving us that extra couple of seconds now because they know they're going to get nailed."

Of course, hitting is what led to the arrest of three Flyers players a week ago in Toronto. Returning to the scene of the alleged crime in hopes of finishing off the Leafs, the "Flyers Three" say they want to forget the past and look to the future.

"We're here to play hockey, nothing else," said a serious Don Saleski. "What happened has happened, and that's up to other people now. It's forgotten. What we're concentrating on now is wrapping this thing up."

Rabb is a Lenoir, N.C. native who attended North Carolina State University and came to graduate school at UNC in 1940 and joined the UNC physical education department. He has been on the Tar Heel campus ever since.

After serving several years as assistant baseball coach under the famed Bunn Hearn, Rabb was named head coach in 1957 after Hearn's death. Actually Rabb directed the Tar Heels much of the time in the late 1940s and early 1950s because of Hearn's failing health.

The Tar Heels won their 500th game under Rabb earlier this season. Now his teams have a record of 510 victories, 324 losses and nine ties. Rabb-coached teams have won four Atlantic Coast Conference championships, two district 3 titles and has made two trips to the College World Series.

Don McGlohn
INSURANCE
Hines Agency, Inc.

Brown Again In Coach Of Year

NEW YORK (AP) — Coach Larry Brown of the Denver Nuggets was quick to credit others when informed he had been named the American Basketball Association's Coach of the Year for the third time in four years.

"This is an award which the players, the coaching staff and the fans should share with me," said the 35-year-old Brown, who added that "our goal right now is to win the ABA championship."

The Long Beach, N.Y., native guided the Nuggets to their second consecutive season of 60 or more victories, helping them become the first ABA team to reach that mark. They captured the Western Division title with a 65-19 mark, ring 40 and 42 home games on the way to their current position in the ABA playoff semifinals.

Brown, who played five seasons in the ABA and led the league in assists three of those years, received 19½ of a possible 35 votes in a poll of sports writers. New York Nets Coach

Kevin Loughery was second with 9½ points, followed by Bobby Leonard of the Indiana Pacers who got 4, Hubie Brown of the Kentucky Colonels, and Bob Bass of the San Antonio Spurs, each of whom got one vote each.

SHEILA STOOD OUT
INNSBRUCK, Austria (AP) — Of the 111 medals won at the 12th Winter Olympics here 10 went to United States' athletes and speed skater Sheila Young of Detroit won three of them.

The 25-year-old Miss Young is the first American ever to win three medals in one Winter Olympics.

Miss Young won one of the three medals taken by American athletes in winning the women's 500-meters race. She took one of the three silver medals with her second place in the 1,500 meters and captured one of four bronze medals going to U.S. women by scoring the third best time in the 1,000-meter event.

Scoreboard

Baseball At A Glance
By The Associated Press
NATIONAL LEAGUE

Team	W	L	Pct	GB
Bris	6	3	.625	1/2
Phila	6	3	.500	1 1/2
New York	6	3	.444	2
Chicago	4	5	.444	2
San Diego	4	6	.400	2 1/2
St. Louis	3	5	.375	2 1/2
Montreal	3	5	.375	2 1/2

California at Milwaukee, (n)
Boston at Chicago, (n)
Only games scheduled

Team	W	L	Pct	GB
Houston	8	5	.615	—
Cincinnati	6	4	.600	1/2
Atlanta	6	4	.600	1/2
San Fran	5	5	.500	1 1/2
San Diego	5	4	.555	2
Los Ang	2	8	.200	4 1/2

Pro Hockey At A Glance
By The Associated Press
NHL Playoffs
Quarter-finals
Best-of-Seven Series
Thursday's Games

Team	W	L	Pct	GB
Philadelphia at Toronto	1	0	1.000	—
Boston at Los Angeles	1	0	1.000	—
San Jose at Boston, if necessary	1	0	1.000	—
Toronto at Philadelphia, if necessary	0	1	.000	—
New York Islanders at Buffalo, if necessary	0	1	.000	—

WHA Playoffs
Best-of-7 Series
Wednesday's Results
United States Semifinals

Team	W	L	Pct	GB
New England	3	1	.750	—
Indianapolis	1	3	.250	—
Houston	6	1	.857	—
San Diego	1	6	.143	—

Friday's Games
Cincinnati at Montreal
Atlanta at Philadelphia, (n)
New York at Houston, (n)
St. Louis at San Diego, (n)
Chicago at Los Angeles, (n)
Pittsburgh at San Francisco, (n)

Team	W	L	Pct	GB
Philadelphia	3	0	1.000	—
Cincinnati	5	1	.833	—
St. Louis	7	0	1.000	—
New York	4	0	1.000	—
Montreal	3	1	.750	—
Atlanta	3	1	.750	—
Houston	1	3	.250	—
Los Angeles	0	14	.000	—

Thursday's Games
Montreal (Kirby 0-0) at Chicago (R. Reuschel 0-0), (n)
Los Angeles (Rau 1-0) at Houston (Cosgrove 0-0), (n)
Only games scheduled

Team	W	L	Pct	GB
Philadelphia	3	0	1.000	—
Cincinnati	5	1	.833	—
St. Louis	7	0	1.000	—
New York	4	0	1.000	—
Montreal	3	1	.750	—
Atlanta	3	1	.750	—
Houston	1	3	.250	—
Los Angeles	0	14	.000	—

AMERICAN LEAGUE

Team	W	L	Pct	GB
New York	7	2	.778	—
Milwaukee	5	2	.714	1
Boston	5	5	.500	2 1/2
Detroit	4	4	.500	2 1/2
Cleveland	3	4	.429	3
Baltimore	4	6	.400	3 1/2

Friday's Games
Cincinnati at Montreal
Atlanta at Philadelphia, (n)
New York at Houston, (n)
St. Louis at San Diego, (n)
Chicago at Los Angeles, (n)
Pittsburgh at San Francisco, (n)

Team	W	L	Pct	GB
Philadelphia	3	0	1.000	—
Cincinnati	5	1	.833	—
St. Louis	7	0	1.000	—
New York	4	0	1.000	—
Montreal	3	1	.750	—
Atlanta	3	1	.750	—
Houston	1	3	.250	—
Los Angeles	0	14	.000	—

Wednesday's Results
New York 10, Chicago 7
Texas at Cleveland, ppd rain
Kansas City at Milwaukee, ppd rain
Baltimore 5, California 1
Detroit 7, Oakland 3
Thursday's Games
Kansas City at Milwaukee, (n)
Friday's Games
Texas at Detroit
Oakland at Cleveland, (n)
Kansas City at New York, (n)

Team	W	L	Pct	GB
Philadelphia	3	0	1.000	—
Cincinnati	5	1	.833	—
St. Louis	7	0	1.000	—
New York	4	0	1.000	—
Montreal	3	1	.750	—
Atlanta	3	1	.750	—
Houston	1	3	.250	—
Los Angeles	0	14	.000	—

Every Day You Wait, It's Money Through The Roof
Eastern Insulation Service
Call for free estimate
Phone 752-1154

Ham, Bacon or Sausage with one egg, grits, toast, jelly. 80¢
Two eggs, grits, toast. 75¢
Egg Sandwich 35¢
CAROLINA GRILL

Spring Boat Show

FREE! SNACKS & PEPSI-COLA
DON'T MISS THE FUN!
THURSDAY THRU SUNDAY
April 22nd to April 25th

Make plans now to attend the boat show at Allen Dean's Sports Center on the new Greenville Blvd., N.E. One of the largest inventories of Grady-White, Marquis and Ranger boats will be on display!

Have Your Boat INSPECTED FREE By A Member Of The U.S. COAST GUARD
Register For A 10' Monarch Open Fishing Boat And A 1/2" Sea Nymph Canoe To Be Given Away FREE!!

4 To 8 P.M. Friday, April 23
1 To 5 P.M. Saturday, April 24

ALLEN DEAN'S SPORTS CENTER

Located Across The River On The New Greenville Blvd. NE
DEALER NO. 8451
STORE HOURS: MON.-FRI. 9-4 P.M. SAT. 9-4 P.M. Phone 752-8610
SERVICE DEPT. OPEN 8 A.M. - 5 P.M., MON.-FRI.

KENTUCKY STRAIGHT BOURBON WHISKEY - 86 PROOF - © 1976 OLD CHARTER DIST. CO., LOUISVILLE, KY.

Charter is one way I pay myself back for all the sacrifices.

OLD CHARTER
It's the best you can do.

\$5.50 Fifth
\$3.55 Pint
\$11.95 1/2 Gal.

ALLIED Petroleum Corporation

"Where Warm Friends Meet"

Call us for all your L.P. Gas, Kerosene, and Fuel Oil heating needs. Service Is Our Policy.

415 West 14th St., Greenville
Telephone 758-1277 or 752-6700

declaration of value!

26 In. 10-Speed Boy's Racing Bike

- Tube steel racing frame, blue enamel finish!
- Dual caliper brakes! 4-safety reflectors!

\$79.99 In The Carton
Offer Expires April 27
(Add \$7.50 If Assembled)

WESTERN AUTO
629 Dickinson Ave.

Utilities Commission Loses 2

RALEIGH (AP) — It may be some time before replacements are named for Chairman Marvin R. Wooten and Commissioner George T. Clark Jr. who have resigned from the state Utilities Commission, the governor's office said.

The delay would be deliberate, a money saving effort, a

spokesman for Gov. Jim Holshouser said. Commissioners are paid \$30,000 a year. State officials are seeking ways to cut spending for next fiscal year because a revenue deficit is expected.

Wooten will leave April 30. He resigned to take a post as a

federal bankruptcy judge for the state's western district.

Clark said he will resume private law practice in Wilmington. His last day will be June 30.

Named to the commission in 1968, Wooten was appointed chairman in 1972 by former Gov. Bob Scott. His term will

expire June 30, 1977.

Clark was appointed by Gov. Jim Holshouser two years ago and his term runs through June 1981.

Holshouser, a Republican, now has an opportunity to appoint two more commissioners. Of the seven seats on the panel, the only Democratic appointee left will be Ben Roney, named in 1972 by Scott.

Because the General Assembly must approve commission appointments, Holshouser's nominees could be rejected. The appointments could be left to the next governor.

A third opening may occur on the panel. Barbara Simpson, who was appointed last year, has been nominated by President Ford for a seat on the Federal Power Commission. That nomination is now before the Senate for approval.

Wooten was appointed to the bankruptcy court by Chief Judge Woodrow Jones in Statesville who said Wooten's administrative and judicial experience qualified him for the job.

A native of Sampson County, Wooten, 47, is a Wake Forest law school graduate and practiced law in Hickory before becoming judge of the municipal court and juvenile court there from 1958 to 1961.

He became chairman of the state Board of Paroles in July 1965 and left that panel when he was named to the Utilities Commission.

Wooten will assume his new duties May 1 with offices in Charlotte, Jones said. He fills a vacancy created by the resignation several months ago of Joseph Cruciani.

Wooten predicted that his and Clark's resignations would not cause any significant changes in the commission. He said he believes he acted as a consumer advocate, but the law re-

quires that the commission protect the financial stability of the utilities.

In accepting the resignations "with regret," Holshouser said, "Both of these men have rendered outstanding service during a very difficult time in the life of the commission. They have had to participate in some tough decisions, but in the final analysis, the people of North Carolina are going to be thankful that we had men of this caliber serving on the commission during this particular time. As time goes on, more and more people are going to realize that they served the people of North Carolina well."

Ad Embargo Claimed By Callaway Investigator

CRESTED BUTTE, Colo. (AP) — Advertising has fallen off dramatically in a weekly newspaper whose articles led to a Senate investigation and the subsequent resignation of President Ford's former campaign manager, Howard "Bo" Callaway.

The newspaper's publisher, Myles Arber, insists that his Crested Butte Chronicle is the target of an organized boycott. But businessmen who have withdrawn their ads say they acted on their own.

"I will print to the end of spring. That's two months," Arber said Wednesday. "But if business doesn't change by the Fourth of July, I'll have no other

recourse but to close the doors."

Arber, a 33-year-old New Yorker who came here about five years ago, said his paper, which has a circulation of 2,500, has shrunk from an average of 24 pages to eight pages a week. He declined to give a dollar value of the lost ads.

Arber said the advertisers' alleged boycott began last month after he published allegations that Callaway misused his power when he was secretary of the Army to bring about a favorable U.S. Forest Service decision on expanding the Crested Butte ski area.

Callaway, majority shareholder and board chairman of

the resort, left his campaign post two days after the first article appeared and a day after Sen. Floyd K. Haskell, D-Colo., announced that he planned subcommittee hearings on the allegations.

Arber contended that Bill Sweitzer, head of a natural gas company, organized the alleged boycott of his paper. Sweitzer denied it.

"I called up 8-10 people I know and asked them to read the paper to see if they wanted to continue supporting it," Sweitzer said. "That's all I did."

Sweitzer's firm is located in Gunnison, 28 miles from the western Colorado ski area. He said his firm has not placed an ad in the Chronicle since the ski area controversy began.

Sweitzer said he objected to Arber calling local people "weak, stupid, spineless." Arber used those words in an article alleging conflicts of interest among executives of the ski area developer, the Crested Butte Development Corp., who also serve on the town council of Mount Crested Butte, a company town at the resort.

Graves Decorated For Easter Robbed

GREENSBORO, N.C. (AP) — Three women relatives had three things in common. Each had lost a child through illness. The children are buried in the same area of Lakeview Memorial Park. And it has become a family ritual to decorate the graves with Easter baskets each year.

Now they have something else in common. Wonderment that anyone could have been mean enough to steal the baskets, down to the last flower, chick and rabbit.

When members of the family went to the cemetery to take away the decorations after Easter, they found that someone had already done so.

"It really upset all of us," said Pat Walters, whose daughter died at the age of 12 of a kidney disease a decade ago. "Even now, all these years after my daughter died, I can still have my bad days over it. And then, to have something like this happen just seemed to bring it all back again. I just can't imagine what kind of person would do it. I obviously had to be someone who has never been touched by any tragedy in life. You just couldn't do such a

think if you had ever experienced such a loss."

The other women are her sister, Marie Shatley, and Mrs. Shatley's only surviving child, Mrs. Tammy Taylor, who lost her infant son six months ago. The other Shatley child was a 4-year-old girl who died of cancer 11 years ago.

"We realized that our children were dead and couldn't enjoy the decorations," Mrs. Walters said. "But the other little children who came to the cemetery with their parents always seemed to enjoy them."

"We had Easter baskets with flowers and little chicks and rabbits, the usual kind of things. And I think it really helped little children take a different look at the cemetery."

"There have even been times when we wouldn't go near the graves because so many children were around them looking at the baskets. The children liked it. And besides, it was something we wanted to do."

TV Log

WNCT-TV Ch. 9

THURSDAY	
7:00 Truth Or	12:30 Search For
7:30 Hollywood Sq.	1:00 Young And
8:00 Waltons	1:30 World Turns
9:00 Hawaii 5-0	2:30 Guiding Light
10:00 Amer. Parade	3:00 All in Family
11:00 Newswatch	3:30 Match Game
11:30 Movie	4:00 Tall Tales
	4:30 Brady Bunch
FRIDAY	
4:00 Car. Today	5:00 Gunsmoke
8:00 News	5:30 Newswatch
9:00 Kangaroo	6:30 News
10:00 Price Right	7:00 Truth Or
11:00 Gambit	7:30 Make A Deal
11:30 Love Of	8:00 Sarah
11:55 Graham Kerr	9:00 Fri. Movie
	11:30 Newswatch

WITN-TV Ch. 7

THURSDAY	
7:00 Farm Affair	12:30 Take Advice
7:30 Nash Music	12:55 NBC News
8:00 Bonanza	1:00 Somerset
9:00 Movie	1:30 Days of Lives
11:00 News	2:30 Doctors
11:30 Tonight	3:00 Another Wid.
	4:00 Lone Ranger
	4:30 Bewitched
FRIDAY	
5:30 Del Reeve	5:00 Ironside
6:00 Almanac	6:00 News
7:00 Today	6:30 NBC News
7:25 News	7:00 Farm Affair
8:30 Today	7:30 Adam 12
8:25 News	8:00 San & Son
9:00 Mike Douglas	8:30 Practice
10:00 Sweepstakes	8:57 News Update
10:30 High Rollers	9:00 Rock Files
11:00 Fortune	10:00 Police Story
11:30 Hollywood	11:00 Tonight
12:00 News Noon	1:00 Mid. Special

WCTI-TV Ch. 12

THURSDAY	
4:30 Maverick	1:00 Ryan's
7:30 Truth	1:30 Rhyme
8:00 Katter	2:00 Pyramid
8:30 Camera	2:30 Bank
9:00 San Fran	3:00 Hospital
10:00 Harry O	3:30 One Life
11:00 News	4:00 Flintstones
11:30 Mannix	4:30 Comedy
1:45 News	5:30 News
FRIDAY	
7:00 Morning	6:30 Maverick
9:00 Montage	7:30 Tell Truth
10:00 Women	8:00 Donny
10:30 Girl	9:00 Movie
11:00 Edge Of	11:00 News
11:30 Happy	11:30 Rookies
12:00 Make Deal	12:35 News

WUNK-TV Ch. 25

THURSDAY	
7:00 Making Count	4:30 Sesame St
7:30 NC News	5:30 Elec Co
8:00 Firing	6:00 Zoom
9:00 China	6:30 Carras
	7:00 Aviation
	7:30 Black Perspac
FRIDAY	
3:00 Now	8:00 Wash Week
3:30 Canines	8:30 Wall St
4:00 Mls Rogers	9:00 Theatre
	10:00 Suskind

CAMPUS LIBRARY
ST. LOUIS (UPI) — The University of Missouri St. Louis campus library subscribes to more than 1,400 periodicals.

Mazda announces the Air Break.

Free air conditioning worth \$435 off the list price.

From now until May 31, you can get free Mazda™ air conditioning on 1976 Mazda RX-4's and the exciting new Cosmo at participating Mazda dealers. That's a cool \$435 off the list price.

29 mpg highway, 18 mpg city*

It's just one more reason to come in and test drive a rotary engine Mazda. Another is our great gas mileage. Both Cosmo and the RX-4 line are EPA rated 29 mpg highway, 18 city.* As

Car and Driver raves: "there isn't a new car on the road able to match both a Mazda's acceleration and its fuel economy.!"

Now extra value

And now there's free Mazda™ air conditioning, too. But you'll lose your cool if you don't act fast.

Come in for a test drive today!



Mazda Cosmo

Hmmm **mazda**
Not your ordinary car.
GRANT MAZDA
117 W. 10th Street
Greenville
(919) 758-1123

*EPA Federal estimates for 1976 Mazda RX-4's and Cosmo with standard engine and 5-speed manual transmission. Mileage you get may vary with car condition, equipment and the way you drive.
†Copyright © 1976 Ziff-Davis Publishing Co., Inc. REPRINTED BY PERMISSION OF CAR AND DRIVER MAGAZINE.
Mazda's rotary engine licensed by NSU-WANKEL



Whirlpool

FOOD FREEZER

• All Sizes From 6' to 27'
• Porcelain Interior
• Uprights In Color
• Defrost Drain
• Lock

BOB'S T.V. & Appliance Limited Quantity...
BUY NOW!

108 E. 2nd St. Ayden, N.C. 746-4021 | 1702 W. 5th St. Greenville, N.C. 752-6248



"Discount Prescription Prices"

BIG VALUE DRUGS
HARRIS SHOPPING CENTER
1102 W. 3rd St., Ayden, N.C.
Open Mon.-Sat. 8 a.m.-8 p.m.
Phone 746-3026.

BIG VALUE DRUGS
2800 E. 10th St., Greenville, N.C.
Open 9-9 Mon.-Sat.
Phone 758-2181

Closed Sundays
We Reserve The Right To Limit Quantities

DISCOUNT DRUGS

Be Aware!
— Compare —
Our Low Photo Finishing Prices

12 Exposure Roll Kodacolor	Only 3.88
20 Exposure Roll Kodacolor	5.99
Movie Film	2.25

"WE DISCOUNT PRICES — NEVER QUALITY OR SERVICE."

PRICES EFFECTIVE THURS.-FRI.-SAT.

 <p>88's Big Value 49c</p>	 <p>Big Value 89c</p>	 <p>.5 Oz. Big Value \$1.19</p>
 <p>40 Tablets Big Value 99c</p>	 <p>4.5 Oz. \$1.49 Big Value</p>	 <p>8 Oz. Regular w/body Big Value 99c</p>
 <p>100's Big Value 99c</p>	 <p>10's Big Value \$1.09</p>	 <p>4 Oz. \$1.29 Big Value</p>
 <p>Liquid 12 Oz. Big Value \$1.29</p>	 <p>4 Oz. Big Value \$1.49</p>	<h3>Sudden Tan Foam</h3> <p>3 3/4 Oz. Big Value \$2.19</p>
 <p>8 Oz. Big Value \$1.19</p>	 <p>Non-Aerosol Deodorant 3 Oz. Regular Or Neutral Big Value \$1.49</p>	 <p>Big Value \$1.89</p>

Big Black Market In Babies Prospers

By HOLGER JENSEN
Associated Press Writer
LOS ANGELES (AP) — Babies are being sold in a fast-growing black market that charges anywhere from \$5,000 for an illegal adoption to \$50,000 for a custom-made child.

Healthy white infants have become such a profitable commodity in the United States that law enforcement officials fear the Mafia will soon become involved.

"It's a racket very susceptible to organized crime," said Deputy Dist. Atty. Richard Moss of Los Angeles. He said there already seems to be a "loosely connected organization of child traffickers cooperating with each other in transporting babies across state lines."

Some states say they are dusting off ancient antislavery statutes to combat the flourishing people trade. Others are waiting for Sen. Walter Mondale's subcommittee on children and youth to come up with federal legislation.

But right now, baby brokers are taking advantage of too many gray areas and loopholes in state adoption laws. They are profiting because the demand for a certain type of baby exceeds the supply.

"We're going through an in-

credible, nationwide baby hunger at a time when adoptable infants are becoming scarce," said Charlotte DeArmond of the California Children's Home Society.

There is no shortage of children as such. Illegitimate births are at an all-time high of more than 400,000 a year, and the U.S. Department of Health, Education and Welfare says 120,000 children are available "for whom adoption would be best."

But they are either too old, the wrong color, or afflicted with muscular dystrophy, cerebral palsy or various psychological ailments. Selective foster parents are lining up for another kind of child: white, newborn, healthy and unwanted.

Changing social mores, improved contraceptives, liberalized abortion laws and society's fading disapproval of unwed mothers makes this child a rarity. Thus he has become a prime target of black marketeers.

"The waiting list for white babies is now three to five years, while you can get a black baby in nine months," said Mrs. DeArmond. "That's the real tragedy. There would be no black market if parents

were less selective."

Joseph Reid of the Child Welfare League of America added that legitimate adoption agencies simply cannot compete with unscrupulous profiteers who offer pregnant girls large sums of money and pay all the medical bills for healthy white babies.

Children's agency officials estimate that one baby is sold on the black market for every 20 who find a home through legal adoption procedures. Moss suspects it is higher in California because the population density provides more buyers and merchandise.

The state accounts for more than 10 per cent of the nation's illegitimate births, its adoption laws are lax and Californians usually lead the field in bizarre consumer trends.

such developments in his state, but he says he is powerless to prosecute for lack of evidence.

"The mother who sells her child won't talk because she's been paid off," he said. "The foster parents won't talk because they want to keep the child. The intermediary won't talk because he made most of the profit. And the child is too young to talk."

Moss has become something of an expert in this barely tapped criminal field because he handled California's only successful prosecution of a major baby selling ring, which was headed by former Los Angeles County crime commissioner Ronald Silverton.

Moss said Silverton had "set up the machinery to sell babies on a mass scale, with price tags of \$10,000 to \$15,000." But he was only convicted on three counts of conspiracy, operating an illegal home-finding agency and advertising an illegal home-finding agency.

Silverton was sentenced to a year in county jail, three years probation and a disbarment. He is currently free on appeal.

"That's the trouble, there are no specific statutes against baby selling," says Moss. "We definitely need some federal legislation."

California law sets a maximum \$500 fee for adoptions and requires state licensing of home-finding agencies and other intermediaries in the adoption process. But it also allows "independent adoptions," where a mother can select foster parents for her child and

handle the deal through her attorney.

This is the gray area that permits the black market to flourish. Did the mother really find the foster parents? Did she sell her baby or give it away? Was the attorney simply a legal assistant in the transaction or did he become a unlicensed home-finder?

"It's very easy to tell," said Betsy Cole of the Child Welfare League's North American Center for Adoption in New York. "Legal fees in any adoption should run no higher than \$200. When lawyers start charging \$10,000 and \$15,000, you know they're doing something more."

"The trouble is proving it. Like doctors, lawyers have an unwritten conspiracy to charge what the traffic will bear and supply what the public wants — in this case babies or parents for babies."

Only five states have outlawed independent adoptions — Connecticut, Delaware, Michigan, Minnesota and Massachusetts. The others have easy licensing requirements or permit natural mothers to do their own placement, thus falling prey to black marketeers.

Many of the culprits say they are doing nothing wrong. They have garnered considerable public support for the argument that baby selling is a victimless crime where no one gets hurt and everyone winds up happy.

Silverton, for example, called his baby-selling operation the "Save a Life Adoption Agency."

hearings in 1975, several lawyers testified that they were actually performing a public service in finding homes for unwanted babies, paying hospital bills for destitute mothers and satisfying the parental cravings of childless couples.

One Florida attorney even admitted setting up "houses for unwed mothers" that guaranteed superior medical care — all free — and wealthy foster parents for their babies.

Moss concedes there are some cases where it might be a victimless crime, "but in others everyone is the victim."

"The adopting parents are being exploited by paying exorbitant fees, and they're vulnerable to blackmail at a later date. The natural mothers are reduced to baby-making machines, and thus robbed of human dignity."

"The child is the main victim because the only determination in selecting parents is who can pay the most. And then there are all those other victims — adoptable children who might have found homes if the black market didn't provide so many healthy white babies."

Mrs. Cole agrees that while many attorneys have bent their ethics to become involved in the baby trade, few are unscrupulous enough to sell infants to alcoholics, sex deviates or obvious psychotics.

"Most of the people who buy babies are not bad parents. It's just that the potential is there for great harm to the child," she said.

1960	224,300
61	240,200
62	245,100
63	259,400
64	275,700
65	291,200
66	302,400
67	310,100
68	339,200
69	360,800
70	390,700
71	401,400
72	403,200
73	407,300
74	418,100

Source: Dept. of Health, Education, and Welfare

Self-Sufficiency Is Couple's Goal

WALLA WALLA, Wash. (AP) — Sonia Trapani rarely goes to the supermarket.

She, her chiropractor husband and three children raise all their own food, except for honey for sweetening, milk and salt, on an 11½-acre farm.

Dr. Francis Trapani, 42, her husband, believes that natural catastrophes in the future, possibly a series of severe earthquakes, could have a devastating impact on the nation's urban millions by shutting off the supply routes to food.

"If we did have a critical time, a national disaster, who would be the better able to handle it, the guys in the city or guys like us?" he asks.

His wife adds, "We feel in the near future people are going to this as a matter of need. Now it's a matter of choice."

She and her husband raise their own cattle and poultry and grow all their vegetables, including wheat for bread. What they harvest in the summer and fall they freeze-dry, or can for winter.

Former Hawaiians, they are "about 98 per cent self-sufficient" in producing their own food, Trapani said.

The family plans to heat their home entirely with wood next winter. Next they plan to buy a woodburning steam engine to power a generator for electricity.

The family began home-gardening two years ago, in part because they believe in the nutritional value of home-grown food without chemical additives, preservatives and coloring.

They also weren't comfortable being dependent on others for food.

In Kahaluu on the Hawaiian island Oahu, Trapani operated a chiropractic clinic and hosted regular television and radio programs on health and nutrition.

But, his wife said, theirs was "a life that was moving us along: tensions, pressures, the

high cost of living."

They became worried that they, like almost everyone else on the Hawaiian Islands, were utterly dependent on the mainland for food, she said.

The Trapanis say they were also doubtful about the nutritional value of the food available on the islands. Fruit arrived packaged in nitrogen and the tastes of apples, pears and bananas were almost interchangeable, they said.

"We've moved from Paradise (Hawaii) to Walla Walla," Mrs. Trapani said. "But it's been an upward move."

They decided to return to the mainland, to a place where they could grow all that they ate. Using weather and population charts and a world atlas, the Trapanis selected southeastern Washington, and moved to Walla Walla in 1974.

They agreed Walla Walla seemed to have the combination of mild winters, rainfall and the isolation from metropolitan areas they sought.

While the Trapanis strive for self-sufficiency, they say the concept in many ways is impossible to achieve.

"You can't live your life completely self-sufficient," Mrs. Trapani said. "We require a tractor somebody else has made. And fuel."

A California mother once gave her baby to a broker for a used car.

Another childless couple paid \$50,000 for a baby "made to order," selecting the parents from photographs of attractive, young, single men and women in an album compiled by their attorney.

Some attorneys have actually placed classified ads in California newspapers: "Young people wish to adopt baby at birth. Will pay doctor and hospital bills. Replies confidential."

Others are paying finders fees to college students for every pregnant coed they locate on campus.

Moss pays close attention to

Save \$2.00

GOOD FOR \$2.00 OFF ANY 15" PIZZA ★

Good Off Regular Price Only
Good only at participating Pizza Hut restaurants listed below. Offer good thru April 25, 1976

**2601 E. 10th St.
Greenville, N.C.**

Our people make it better

Wickes Lumber

HANDYMAN VALUES

PRICES GOOD THRU APRIL 29th

SPACIOUS, STYLISH

10'x7' STORAGE BUILDING

\$129.95 Each
Reg. \$139.95

NOW SAVE \$10

10'x7' METAL RED BARN BLD 7867 Reg. \$159.95 **\$149.95**

10'x10' STORAGE BUILDING 7860 Reg. \$169.95 **\$159.95**

SAVE \$10 ON EITHER!

WROUGHT IRON RAILING

Easy-to-install sections enhance the safety, beauty and value of any home. 4' & 8' Sections

\$129
Per Ft.

Posts & mounting hardware available at additional charge.

REDWOOD FURNITURE

Made of quality 100% redwood lumber, this set lets you really enjoy outdoor living. An exceptional value!

\$79.95 4 Pc.

SAVE \$10.00

RED BARN BUILDING

Protect your expensive lawn & garden tools with a sturdy, attractive wood Storage Building.

\$419.00

8' x 12' inside dims.

16'x24' GARAGE

Complete package includes plans, pre-assembled components. Do-it-yourself and save!

From \$1,229.00

GARDEN HAUS BUILDING

Strong, attractive wood Storage Building provides ample space for lawn & garden tools, sports equipment.

\$299.00

10'x10' w/nom. inside dims.

POST/LANTERN COMBO

Provides safety, illumination and a touch of style to any yard! Black finish. Easy to install.

\$17.99 435143 Complete

FIBERGLASS PANELS

Strong yet lightweight! Ideal for carports, mobile home skirting, patio covers, etc.

\$2.99 8' Length

READY MIX CONCRETE

Easy-to-use Sakrete. Just add water for a strong concrete mix; perfect for almost every need!

\$1.99 90 Lb. Bag

MAGICOLOR EXT. WOOD STAIN 47291 **\$7.97**

MAGICOLOR INT./EXT. SPRAY ENAMEL 13 Oz. Can **\$1.07**

12' STANLEY TAPE MEASURE Reg. \$6.29 **\$5.99**

8' TREATED LANDSCAPE TIMBERS **\$2.79**

STANLEY 16 OZ. STEEL HAMMER 416213 Reg. \$8.29 **\$7.99**

STOCKADE FENCE

Sturdy Northern White Cedar! Gates & posts extra.

\$16.99 4' x 8' Section
6' x 8' Section **\$19.99**

Lasso works in corn, soybeans and peanuts.

LASSO® HERBICIDE
Lasso is a registered trademark of Monsanto Company.
Always read and follow label directions.

Wickes Lumber

125 W. Greenville Blvd. Greenville, N.C. Phone 758-7144 Monday-Friday 8:00 am - 5:30 P.M. Saturday 8:00 am - 4 P.M.

Hwy. 284 By-Pass Farmville, N.C. Phone 753-3111 Monday-Friday 8:00 am - 5:00 p.m. Saturday 8:00 am - 3 P.M.

© Wickes Corp. 1976 0022 76C

LONG ON VALUE

Canada Dry Bourbon

\$10.40 ½ GAL.

\$4.75 FIFTH

\$3.00 PINT

80 Proof Kentucky Straight Bourbon Whiskey.

Canada Dry Gin

\$9.50 ½ GAL.

\$4.10 FIFTH

\$2.65 PINT

86 Proof Dry.

Canada Dry Vodka

\$9.00 ½ GAL.

\$3.85 FIFTH

\$2.40 PINT

All Canada Dry half gallons feature the easy pour spout and convenient handle.

80 Proof You'd pay a lot more if we called it Canada Dryski.

Stitzel-Wellers CANADA DRY
Bourbon/Gin/Vodka

GIN AND VODKA, 100% GRAIN NEUTRAL SPIRITS. STITZEL-WELLER DISTILLERY CO., LOUISVILLE, KY.

Coed's Mutilated Body Found In Wooded Area

CHARLOTTE, N.C. (AP) — Four days ago, Vickie McKinney confided to a friend that she worried about dying alone.

Wednesday, the pretty coed's mutilated body was found lying in a thinly wooded area, several hours after she was kidnaped from the campus of Central Piedmont Community College in Charlotte.

Leroy Johnson, 32, of Charlotte, who was paroled five months ago from a state prison, was jailed without bond on charges of murder, kidnaping and robbery with a dangerous weapon, police said.

Miss McKinney spoke of death in a conversation last Sunday because her parents were to be out of town overnight and she feared staying alone, said a close friend, Emily Jones, 18.

"She said to me that if she ever died she didn't want to die alone," Miss Jones said.

"She always stayed with friends when her parents were

of town and she was thinking about staying at home alone for the first time," Miss Jones said. "I told her she should stay with friends and she did."

Miss McKinney, 19, a college freshman, was enroute to her first class of the day when she was abducted from a college parking lot shortly before 8 a.m., investigators said.

Police Maj. D. R. Stone said a witness told officers she saw Miss McKinney stop her car in the parking lot and then saw a man apparently force his way into the backseat and make her drive away.

He said the assailant reportedly "had his hand around her neck in such a way the possibility was he had a knife."

The witness, a young Charlotte woman, immediately called police, who issued an all-points bulletin for Miss McKinney's car and launched a search in the southeast sector

of the metropolitan Charlotte area, near the Mecklenburg-Union County line.

About two hours later, officers said, two patrolmen spotted the car on U.S. 74 and followed it into a service station, where they arrested Johnson without incident. Police reported that a revolver and a pocketknife were taken from Johnson, who was held without charges for several hours until the body was found and identified by relatives.

Officers in a police helicopter spotted the victim lying face up in a wooded area off U.S. 74 near Matthews, just southeast of Charlotte. Her nude body had been slashed with a knife and apparently ripped by gunfire, Stone said.

"Her body was damaged," Stone said. "Her throat was damaged and her eyes were damaged...The preliminary investigation shows stabbing and gunshot wounds but that won't be official until an autopsy is performed."

Weaver Recalls Colorful Career

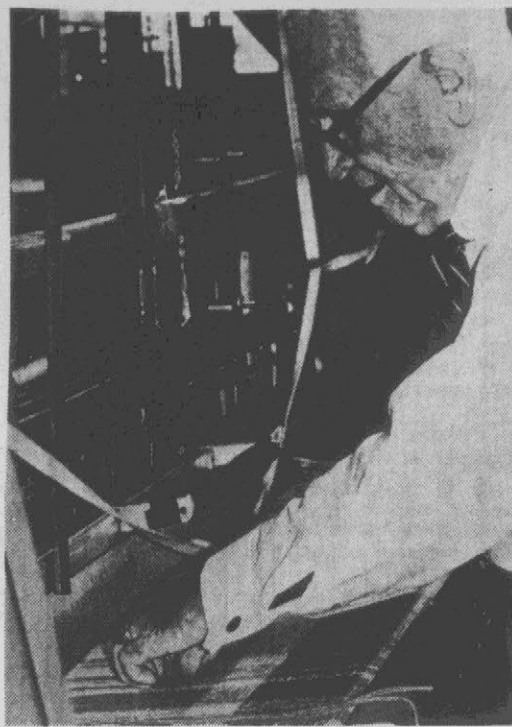

WEAVER AT WORK—Bill Spencer, framed by a hand loom he designed, is at 71 still very much in the picture at the hand weaving company he founded nearly 50 years ago in Houston.

HOUSTON (AP) — With obvious enjoyment, William B. "Bill" Spencer adds another strand of color to his hand weaving experiment as he talks.

His conversation, like his work as designer and color consultant for the hand weaving company he founded here nearly half a century ago, is full of color and detail.

"Once we received an order from an airline for a dozen white throws. I couldn't figure why anyone would want white throws for a plane." A pause and he chuckles. "They were for the Aga Khan's bridal plane."

"We made handwoven blankets for the White House during Truman's administration. I'll never forget the labels they sent for us to sew in. They were white taffeta with gold lettering, 'For the White House' and a gold star in each corner."

Spencer, who sold the Three Weavers company in 1970 "so my wife Mary and I could do more traveling," admits he hasn't been able to break the worst wool ties that bind him to the business.

"Remember when rose and dull blues were popular decorating shades to coordinate with damask and oriental rugs? Then wall-to-wall carpeting came into vogue and the colors of our throws and blankets had to be livelier to enhance them. Now the cycle has come around and area rugs are popular again."

Spencer's business has survived a depression, a world war and a major fire.

In 1928 Spencer and two of his friends, all associated with a Houston cotton textile mill, became interested in hand weaving. They purchased a hand loom and some wool yarn and rented a small tin shed to begin their experiments.

"We were The Three Weavers," says the white-haired Spencer.

A year later his partners took positions elsewhere but he continued to experiment with hand weaving techniques toward perfection of a woolen infant blanket for the retail trade.

"Sounds crazy now. Right in the middle of a depression I start a new business of luxury items. There was no money to buy a hot water heater, so I lit a fire under a washtub to wash the blankets. I had no press so I used a local laundry's at 15 cents an hour."

"I remember having three or

four packages with about \$30-worth of blankets inside and I didn't have money to buy stamps to mail them."

The embryo cottage industry had just begun to thrive when World War II was declared and all available wool was channeled into military use.

Disqualified for service because of age, Spencer served as assistant to the president of Wamsutta Mills in New Bedford, Mass.

"When wools for civilian use became available again I reopened my shop and went back into full production. Then early one cold October morning in 1959 fire destroyed 16 looms," Spencer recalls.

With only the two steel looms salvaged, Spencer and his employees started to rebuild.

When new handwoven patterns emerge — a bold lumberjack plaid or a soft tone-on-tone stripe — it is Spencer who has spent many hours at the loom working with dozens of shades of the yarn to get the perfect blend. But first he creates his own yarn colors.

"You can't improve on nature's colors," says Spencer, 71, always crisply dressed in a white shirt with tie and given to elegant pin-striped suits. "For contrast, compare the clear red of a geranium flower with its fresh green leaves. For color harmony, notice how the blue cornflower blends with the dusty sage green of the foliage."

One of the weaver's best known patterns is Joseph's Coat, a design of ten radiant shades woven through each other to produce a hundred different blocks, each in a fine black frame. "I was trying to duplicate a rare, old, stained glass window," he explains.

Spencer makes an intensive study of color trends in the decorator field and produces handwoven fabrics to harmonize.

"I remember having three or

We *Walter* BELT
Rent VIBRATOR

Reducing
Machines
\$15.00
Per Month

Rental Tool Co.
Dial 758-0311
3014-A E. 10th St.

Selling Out To The Bare Walls!

Chances Are That You Need
Furniture — And That You Need
It Now. And There Is No Better
Time To Buy Than Now During
Our Fantastic Money-Saving
Store-Wide Bare Walls Sale.

**HURRY IN TODAY
FOR THESE VALUES!**

THOMPSON'S DISCOUNT FURNITURE

924 DICKINSON AVENUE
ACROSS FROM SHERWIN-WILLIAMS CO.

Car Radio Gear Thefts Are Being Investigated

Greenville Police are investigating a series of citizens band radio and FM converter thefts reported Tuesday and Wednesday, Chief Glenn Cannon said today.

According to Cannon, Mrs. Inez Ambrose of Route 2, Greenville reported at 4:50 p.m. yesterday that a CB radio, valued at \$150, was taken from her car while the vehicle was parked at 1502 North Greene St.

Cannon said thieves apparently unlocked a car door to gain entrance to the vehicle.

At 7:40 p.m. yesterday, Wesley E. Brown of 700 East Church St. reported a CB radio valued at \$150 was taken from his unlocked truck parked behind Waters Service Station on North Greene Street, the Chief noted.

Cannon quoted Brown as saying he had left the vehicle unattended a short while and when he returned, the radio was missing.

Hilda Letchworth of 107 Oakdale reported at 2:55 p.m. yesterday that an FM converter had been taken from her car while parked at Harris Super-

market on North Greene Street.

Cannon said the value of the converter was set at \$30.

William Johnson of 411 North Elm St. reported Tuesday that a CB radio had been taken from his vehicle while parked in a parking lot near the Park Theater in downtown Greenville.

Cannon said the theft was reported about 10:25 p.m. and said entrance to the vehicle was gained through a window.

Value of the radio was estimated at \$149.

According to Cannon, Sam Price of 1106 North Greene St. reported Tuesday that a CB radio and a regular AM radio had been stolen from his truck parked on North Greene Street April 15.

The chief said the Price truck had been broken into and estimated the value of the two radios at \$350.

Benjamin Franklin wrote "Poor Richard's Almanac" under the pseudonym Richard Saunders.

Benjamin Franklin wrote "Poor Richard's Almanac" under the pseudonym Richard Saunders.

Rural Break-In Suspect Seized

Investigation of a rural break-in Tuesday at the home of Edsel Garris, Rt. 5, Box 77, Greenville resulted in an arrest by Pitt County Deputies.

Deputies arrested Levon Bradley, 21, of Rt. 6, Box 84, Greenville on a charge of breaking, entering and larceny at the Garris residence.

Sheriff Ralph Tyson said that two rifles and a shotgun, valued collectively at \$700, were reported stolen from the home.

Bond for Bradley was set at \$800, according to the sheriff.

Would You Like Your
Children Exposed To A
Restaurant Where They're
Waited On, And One That
Won't Cost You A Lot of
Money!

Bring Them To Pier 5 and Try Our
Family Platter That Feeds 4 to 5
People For Just

\$7.95

It's quick, clean, efficient and above all,
friendly!



PIER 5

264 By-Pass — Pitt Plaza
Greenville

Tom Strickland

for GOVERNOR

"Friend Of The Farmer"

HAS SERVED

2 Terms in N. C. House
3 Terms in N. C. Senate

Wake Forest Law School
L.L.B. (J. D. Degree)

University of North Carolina
Chapel Hill
A. B. Degree

Tom Is A Veteran
United States Marine Corps

For Capital Punishment

Strong Supporter Of
ECU Med School



DEMOCRAT

METHODIST

Member of Grange, Farm Bureau,
WOW, Masons, Odd Fellows

Believes That Government
Must Serve The People

Believes In Equal Opportunity
For Everyone

Equal Pay For Equal Work

Sponsored \$5,000.00 Death Benefit For Firemen In North Carolina

Sponsored An Amendment To The Above Bill That Added \$25,000.00 Death Benefit To The Families Of All Firemen, Police Officers And Rescue Squad Members In North Carolina—This Protects Families In Case Of Death In Line Of Duty

Sponsored A Minimum Standards And Salaries Act For Law Enforcement Officers

Sponsored The Criminal Procedures Act Ordering Speedy Trials

Supported Efforts To Establish The Criminal Justice Academy And For Education Of Law Enforcement Officers In Police Academies And Community College Systems

CHAIRMAN OF THE CORRECTIONAL INSTITUTIONS AND LAW ENFORCEMENT COMMITTEE 1971

Strickland

for GOVERNOR **A Step In The Right Direction**

Vote

Paid for by the Pitt County Committee For Tom Strickland For Governor. Sam McLawhorn, Eastern Regional Chairman and Carl Knott, Pitt County Chairman.

Who is George Dickel?



Superb Tennessee Sippin' Whisky, of course!

George Dickel is a native son of Tennessee, where iron-free springwater and crisp, clean environs breed a mellow, refined taste. A charcoal-gentled taste so pure and smooth, you'll know **There's a little bit of Tennessee in every sip.**

© 1976 - Geo. A. Dickel & Co. - 86.9 Proof - Tullahoma, Tennessee

Actor Attacks NEA's Retreat

By BOB THOMAS
Associated Press Writer
LOS ANGELES (AP) — "A bunch of bureaucrats hiding behind desks." That was Arthur Hill's angry answer to the National Education Association's rescinding of its recommendation of the TV special "Judge Horton and the Scottsboro Boys."

FORECAST FOR FRIDAY, APRIL 23, 1976

Your Daily HOROSCOPE

from the CARROLL RICHTER INSTITUTE

GENERAL TENDENCIES: Particularly good for looking into plans important to you and arranging a private campaign to bring you the conditions which are most vital to your well-being and success. Get whatever information you lack from those in power, but do so confidentially.

ARIES (Mar. 21 to Apr. 19) Discuss with the influential or with experts how to become more successful in your field of endeavor. Devote more time to mate.

TAURUS (Apr. 20 to May 20) Be with good pals and casually mention your aims and gain their support. Handle business matters first. Group activities are fine.

GEMINI (May 21 to June 21) You understand now how best to gain favor of bigwigs; contact them early. Join in on some public affair. Avoid troublemaker.

MOON CHILDREN (June 22 to July 21) Planets are favorable and new conditions remove obstacles of the past, so you get much accomplished. Making worthwhile new contacts is easy.

LEO (July 22 to Aug. 21) Get an early start on duties and complete them speedily, without the usual obstacles. Show true devotion to mate for greater rapport.

VIRGO (Aug. 22 to Sept. 22) Talk over with associates how to make mutual ventures more successful and reach fine decisions. Any civic work you do can bring fine results.

LIBRA (Sept. 23 to Oct. 22) Attend to intricate work details and get ahead faster. Find the right items to add to wardrobe for finer impression on others.

SCORPIO (Oct. 23 to Nov. 21) Arrange recreation early for later in the day. Put that particular talent you have to work. Watch expenditures.

SAGITTARIUS (Nov. 22 to Dec. 21) Discuss with kin any points that are open to question and come to fine accord. Some new interest pursued today brings good results.

CAPRICORN (Dec. 22 to Jan. 20) Get information you need from one who is powerful, then you can produce more workwise. Communicate cleverly. Be happy.

AQUARIUS (Jan. 21 to Feb. 19) Use good sensible methods if you want to have more money in the future. Contact business experts if in doubt.

PISCES (Feb. 20 to Mar. 20) Make plan that can increase success; don't limit yourself so much. Show more affection for your mate and get more response.

IF YOUR CHILD IS BORN TODAY ... he or she will be one of those naturally intelligent young people who can solve problems easily. Give the finest education possible in the most modern schools that teach advanced methods. Then your progeny will have a great success in life. The spiritual and ethical side of life should be taught early. Genteel sports are best here.

"The Stars impel, they do not compel." What you make of your life is largely up to YOU!

Carroll Richter's Individual Forecast for your sign for May is now ready. For your copy send your birthdate and \$1 to Carroll Richter Forecast (name of newspaper), Box 629, Hollywood, Calif. 90028.

(c) 1976, McNaught Syndicate, Inc.

what you get. For the NEA to back down now shows a lack of courage." The theme of "Judge Horton and the Scottsboro Boys" is courage, Hill remarked. "The show points up how one individual can change the course of events," the actor said. "Judge Horton was a believer in the 'separate but equal' philosophy, but he simply could not allow perjury in his courtroom. And so the boys, with ages ranging from 13 to 19, were saved from execution. They had been accused of rape by two of the town's prostitutes.

Most people think of Hill as television's unflappable Owen Marshall. But it should be remembered that he was also the original George in "Who's Afraid of Virginia Woolf?" creating on Broadway the rampaging role that Richard Burton played in the film.

Hill's Canadian dander was up when he learned that the NEA had withdrawn its blessing on "Judge Horton and the Scottsboro Boys."

"Apparently the NEA got cold feet after NBC decided to put a disclaimer on the show, stating that the subject matter might be objectionable to some persons," the actor said. "I suppose the network figured it had to do that because of the talk about rape."

"But the script is unchanged from what the NEA read and approved. What you read is

"Prosecution of the boys continued, and one of them didn't get out of prison until 1952. Oddly enough, it was the Communists who kept the case alive and prevented the boys from being killed."

"The Scottsboro case has been largely ignored by today's generation, both white and black. I think that is wrong. Young blacks may be dissatisfied with conditions today. But when they look back and see what it was like in the 1930s, they will feel better about the progress that has been made."



THE STUDENT—What little girl wouldn't envy the chance to make her dreams come true by getting ballet lessons all by herself with a beautiful young ballet instructor? Beth LeMoyné gets an outdoor lesson from Holly Dean Simonds, of Miami, who teaches ballet and modern dance. (AP Wirephoto)

Experts Say Wagon Train Plan For N.C. Too Rough On Horses

CHARLOTTE, N.C. (AP) — Two horse experts who were to have been in charge of the North Carolina leg of a bicentennial wagon train have quit. They said the 12 days allotted for the 250-mile trip could push the horses too hard.

"We could not condone or oversee an activity which may be harmful to horses," one of them, Dr. Thomas Leonard of North Carolina State University, said Wednesday. The other is Glenn Petty of the state Department of Agriculture.

Meanwhile, Richard Ellis, chairman of the North Carolina Bicentennial Commission, said that because of the fears of the horse experts, he may withdraw the commission's help with the train, a project of the Pennsylvania Bicentennial Commission.

"I sure as hell don't want the SPCA (Society for the Prevention of Cruelty to Animals) on my back," Ellis said. "I'd have every little old lady in the state on my back."

The wagon train is one of five now headed across the country for a convergence on Valley Forge, Pa., on July 4. It started in Atlanta and has been scheduled to make its first stop in North Carolina at Dallas near Gastonia on May 10th.

Leonard contends that the Aitken-Kynett Co. of Philadelphia, a public relations and advertising firm that is coordinating the train for Pennsylvania, originally promised him 21

days for the North Carolina leg. However, Aitken-Kynett denies having any record of a commitment for that much time. And a spokesman for the firm said he believed Leonard's fears are unjustified.

Leonard, head of the horse program of the North Carolina 4-H Clubs, said the firm had promised fresh teams of horses for the "official" wagons but had refused to grant the extra day or rest he and Petty had requested when the train was about midway through the state. He said he was worried about the horses which might be used by any private wagoners or horseback riders who would want to join the train and ride across the state, or beyond.

"If they get one of these horses out of the pasture and try to keep up with the train for 12 days, they could have some problems," Leonard said. He was particularly concerned about a 32-mile leg scheduled for May 18 between campgrounds at Snow Camp and Hillsborough, N.C.

The official wagons are the Georgia and South Carolina wagons given those states by Pennsylvania, a wagon given to North Carolina that will be picked up en route through the state, plus a Pennsylvania wagon and chuck wagons.

"I think his (Leonard's) fears are unjustified. There are no problems with the horses," said

Robert C. Gruver, an Aitken-Kynett accounts supervisor and director of the wagon train.

Leonard said the Pennsylvania Bicentennial Commission would ask the Gov. Milton Shapp of Pennsylvania to ask Gov. Jim Holshouser of North Carolina whether Holshouser "wants North Carolina to be a part of this."

"If we're not welcome, we just won't come in, that's all."

If the North Carolina leg is discontinued, the train may stay extra days in South Carolina, and then be transported through North Carolina by truck or trailer," Gruver said.

"I think his (Leonard's) fears are unjustified. There are no problems with the horses," said

Fewer Sales But Price Was Up

ORADELL, N.J. (UPI) — A survey by Drug Topics magazine shows that while drug stores filled fewer prescriptions last year than in 1974, the price of the average prescription rose sharply. Part of the reason for the prescription decline was attributed to the recession, which forced patients to reduce medical expenses. The price of the average prescription rose 7.2 per cent from the year before and the nation's total prescription bill came to around \$7 billion, the magazine says.

CROSSWORD PUZZLE

- ACROSS**
- Retail store
 - Existed
 - Corded fabric
 - Legacy
 - French friend
 - Edible seed
 - The Emerald Isle
 - Mr. —
 - Bishop
 - French composer
 - Labor union
 - New Zealand fort
 - Acidity
 - Studio
 - By that means
 - Preliminary plan
 - Tellurium symbol
 - Danish money
 - Wild hog
 - English scholar
 - Look
 - Fall month
 - Favorite
 - Fish
 - Lyric poem
 - Consolidate
 - Oriental dwelling
 - Mother of Irish gods
 - Mountain in Crete

DOWN

- Tire casing
- Migraine
- Danish weight
- Jumbled type
- Commodity
- Dexterity
- Law-making body
- Vogue; colloq.
- Large bird
- Peg
- Semester
- Talking bird
- Punishment in kind
- John or Jane
- Unequaled
- Textile screw pine
- Old Siamese coin
- Relinquish
- Feminine name
- Beethoven Symphony
- Undisguised
- Always
- Hebrides island
- Olives
- Cain's land
- Turkish chamber
- Abstract being
- Primeval; comb. form

Par time 30 min. AP Newsfeatures 4-22

SOLUTION OF YESTERDAY'S PUZZLE

IMP	BASS	ELL
MIR	ADIT	DIE
PRIM	ROSE	IVA
ARID	RALES	
CORD	TRIDENT	
TRY	MAULS	
	RANGE	ORP
SERIN	GA	OPAL
ORIBI		SPICE
RAT	PLANTAIN	
ATE	LOGE	TAT
SOS	EBOE	ELY

Cancer Strikes The Under-15s

HOUSTON (UPI) — Cancer is second only to accidents as the cause of death of children under 15 years of age, according to the American Cancer Society.

The ACS says childhood cancer accounts for one of 28 deaths compared with adult figures of one of six.

abc southeastern 7
PITT
The most devastating detective story of this century.
BRENFORD/HOFFMAN
"ALL THE PRESIDENT'S MEN"
MON. TUES. WED. 7:00 9:30
Next! "Hindenburg"

GOREN BRIDGE

BY CHARLES H. GOREN AND OMAR SHARIF
© 1976, The Chicago Tribune

Neither vulnerable. South deals.

- NORTH**
♠ 842
♥ 765
♦ 6532
♣ K 84
- WEST EAST**
♠ J1063 ♠ K97
♥ Q10 ♥ J9832
♦ 1097 ♦ A J
♣ Q1052 ♣ J93
- SOUTH**
♠ A Q 5
♥ A K 4
♦ K Q 8 4
♣ A 7 6

The bidding:
South West North East
2NT Pass 3NT Pass
Pass Pass
Opening lead: Two of ♣.

Entries to declarer's hand and dummy play a vital role in many contracts. When there is an easy means of transportation from hand to hand, 25 or 26 points, or even fewer, often prove sufficient to produce nine tricks at no trump. When the preponderance of the strength is in one hand, 27 or 28 points might not prove enough. Entries proved to be the key to this hand.

North's decision to raise his partner's two no trump opening bid to game is open to question. With only 3 points, a flat hand, no inter-

mediate cards and no source of tricks, it is generally wiser to pass. Even if partner is maximum, there is no guarantee that game can be made since most of the time he will have to lead from his own hand.

West led his fourth-best club and declarer won in dummy to take the spade finesse. This succeeded but the contract did not. Declarer had to concede two diamond tricks and could make no more than two tricks in each suit.

Declarer should have counted his tricks. Had he done so, he would have realized that he needed three tricks in diamonds for his contract. The only way he could get them was if East held a doubleton ace and declarer used his quick entry to dummy to lead a diamond toward his hand.

But what about the spade finesse? With careful play, declarer could have created a second entry to dummy for a later finesse.

Observe what would happen if after winning the king of clubs in dummy declarer were to lead a diamond. East follows with the jack and declarer's queen wins. Now declarer plays the eight (!) of diamonds from his hand, and he is fortunate when this fetches the ace. Declarer can now win any return, cash the king of diamonds to extract the last diamond from the defenders' hands and then lead his four of diamonds to dummy's six! A spade finesse would bring his bag to nine tricks.

(The opening lead is the most important single play in bridge. And Charles Goren's "Opening Leads" will help you to substantially increase your winnings. For a copy, send \$1.50 to "Goren-Leads," c/o this newspaper, P.O. Box 259, Norwood, N.J. 07648. Make checks payable to NEWSPAPERBOOKS.)

Crandell Listed In Publication

William A. Crandell of Rt. 1, Stokes, has been included in the annual publication, "Who's Who Of Prominent Citizens of North Carolina."

A farmer, Stokes served in the Air Force during World War II, was shot down over Germany and was a prisoner of war in Stalag Luft No. 4. For 26 years he has been an active member of the Stokes Ruritan Club, and is a member of the Sweet Gum Grove Free Will Baptist Church.

264 PLAYHOUSE INDOOR THEATRE
4 MILES WEST OF GREENVILLE ON U.S. 34

STARTS TODAY

AT YOUR ADULT ENTERTAINMENT CENTER

"C.J. LAING HAS A MIND BOGGLING ABILITY IN A SCENE THAT WILL GO DOWN IN PORN HISTORY. SHE IS THE FRESHEST AND MOST PLEASURABLE THING TO APPEAR ON THE STORM FRONT OF PORNOGRAPHY!"

ANYONE BUT MY HUSBAND

ADULTS ONLY X COLOR
VALID ID REQUIRED
CALL FOR SHOWTIME 756-0848

PLAZA Cinema 1 2nd WEEK OF WAY-OUT FUN!
PITT-PLAZA CENTER • 756-0088

WALT DISNEY PRODUCTIONS
NO DEPOSIT NO RETURN

David RIVER, Barron HOFFMAN, Don KNUTTLE, Herchel BERENSON, and Barbara FELDON

Weekday Shows Sat. & Sun.
3:15-5:15-7:15-9:15 1:15-3:15-5:15-7:15-9:15

Starting April 30th "Last Hard Men" Last Day — Cinema 2 — "Duchess & Dirtwater Fox"

PARK UPTOWN GREENVILLE STARTS TOMORROW!
752-7449

He's been maimed and framed, beaten, robbed and mutilated. But they still can't keep him from the woman he loves.

THE MOST HIGHLY ACCLAIMED HORROR PHANTASY OF OUR TIME

PHANTOM OF THE PARADISE

WILD ROCK HORROR 'N FUN!

IN WEEKDAY SHOWS SAT.-SUN.
COLOR 3:15-5:10 1:20-3:15
7:05-9:00 5:10-7:05-9

LATE SHOW FRI. & SAT. NIGHTS 11:15 P.M.

ADVENTURE ON THE GRAND SCALE!
STEVE McQUEEN
THE SAND PEBBLES

COLOR BY LUXE 20th CENTURY FOX

LAST DAY! "BLACK SHAMPOO" (R)

Robert Redford
as **"Jeremiah Johnson"**
A SYDNEY POLLACK FILM

The man who became a legend.
The film destined to be a classic!

ROBERT REDFORD in A Sydney Pollack Film "JEREMIAH JOHNSON" A Joe Wizan-Sanford Production
Co-Starring WILL GEER • ALLYN ANN McLERIE • STEFAN GIERASCH • CHARLES TYNER • And Introducing DELLE BOLTON • Music by John Rubinstein and Tim McInnre • Screenplay by John Milius and Edward Anhalt • Produced by Joe Wizan • Directed by Sydney Pollack • Panavision® • Technicolor®
Celebrating Warner Bros. 50th Anniversary A Warner Communications Company

Starts Tomorrow!

WEEKDAY SHOWS SAT. & SUN. SHOWS
3-5-7-9 1-3-5-7-9

No Passes Accepted This Engagement

PLAZA Cinema 2
PITT-PLAZA CENTER • 756-0088

Pitt County Broadcasters Association
The C-B Club
"The Original Senior Club Of Greenville"

Invites C-B'ers with F.C.C. numbers to a hot dog supper free of charge for the whole family.

A good old eye ball meeting for the C-B'ers of Pitt County so we can shake your paw.

Time: 7 til 9 p.m., April 23, 1976

Elm Street Park Recreation Building
Elm Street — Near Rose High School
Greenville, N.C.

Fort Defiance Restoration To Be Treasured

CHAPEL HILL (AP)—Fort Defiance is not a fort but a home, and when restoration is completed it will be one of the most picturesque 18th Century buildings in North Carolina.

The major credit will go to

Margaret Harper of Lenoir, a remarkable little lady who more than ten years ago made up her mind that the home built by General William Lenoir could be saved. Some local folks said it was too expensive an undertaking, but Miss Harper and the Caldwell County Historical Society were undeterred.

Sprightly articles found their way into area newspapers; Miss Harper and her colleagues gave illustrated talks around the state; and the legislature provided appropriations to match local contributions. Now, a decade later, the additions have been torn away, and Fort Defiance looks much as it did when the general lived there more than a century and a half ago.

Located in "Happy Valley" near the community of Patter-

son in Caldwell County, Fort Defiance was built in the four years after 1788 and remained in the Lenoir family until it was bought by the Historical Society.

Included in the acquisition was a rich body of documentary materials, including the general's contract for its construction and an early painting of the house. Many of the original family furnishings were also acquired so that, when fully restored, even the interior will carry the flavor of its earlier inhabitants.

William Lenoir was a man of importance in North Carolina history. Born in 1751 in Virginia, he moved as a child with his parents to Edgecombe County, North Carolina. His poor family could not provide him with formal education, but his self-development prepared him for an active military and political career.

In 1775, just as the Revolution was approaching, Lenoir and his wife, the former Ann Ballard of Halifax County, moved to Surry (now Wilkes) County and settled near Mulberry Field (now Wilkesboro). From there he set off on numerous campaigns against the Indians and British.

He was a lieutenant in Griffith Rutherford's expedition against the Cherokees, but his most notable participation was as a captain in Benjamin Cleveland's forces in the Battle of Kings Mountain.

He described his experiences: "I received a slight wound in my side, and another in my left arm, and after that, a bullet went through my hair about where it was tied, and my clothes were cut in several places."

He was, in short, lucky to have escaped. Following the war, Lenoir was a major-general in the state militia for eight years.

In politics, Lenoir held about every position Wilkes County could bestow upon him. He was appointed justice of the peace when the county was formed and held that office for sixty-two years except for two years when he served as clerk of the Superior Court. He also held, at different times the officers of register, surveyor, commissioner of affidavits, and chairman of the county court.

After serving in the House of Representatives from 1781 to 1784, Lenoir went to the State Senate and served almost continually until 1795, the last five years of that period as speaker. Meanwhile, he had been a delegate to the convention which declined to ratify the federal constitution and also the one which did ratify it. Then, in 1808 and 1809, he was president of the Council of State.

It was while he was serving in the Senate that Lenoir selected the site of a pioneer fort a dozen miles up the Yadkin River and began building his house which he named for the

outpost.

In the Senate, Lenoir was influential in the passage of legislation chartering the University of North Carolina, and he was selected president of the first board of trustees. Lenoir Hall on the university campus honors him. Also named for him are a county and a town.

Lenoir was straight-laced in his political principles. "I never asked a man for his vote yet, and I think it such an imposition on a freeman to do it, that I hope I shall never be guilty of so great an insult on the understanding and liberty of my countrymen," he said.

Unwilling to adopt the electioneering tactics of his opponents, Lenoir lost his legislative seat to his former tenant, James Wellborn, and he never again won elective office. He continued, however, to hold the appointive office of justice on the county court.

In 1839, at the age of eighty-seven, General Lenoir rode horseback fifty miles to attend court in Ashe County. A few weeks later, on May 6, he died and was buried in the garden at Fort Defiance.

There, looking out upon Happy Valley, the Fort Defiance

restoration will honor a founder of the independent state, the county of Wilkes (Fort Defiance is now in Caldwell), and the University of North Carolina.

Prisoner Gets Death Penalty

RALEIGH (AP)—A 30-year-old prison inmate has been convicted of murder in the strangling of a prison dental assistant last May and sentenced to die.

A Wake Superior Court jury deliberated about five hours Wednesday before it found James Lee Primes guilty in the slaying of Mrs. Jeannette Wood Fish, 42. She was found strangled to death in her office in the Triangle Correction Center last May 19.

Primes is the 108th person on North Carolina's death row. His death sentence will be stayed by an automatic appeal to the U.S. Supreme Court.

The state contended that Primes had made sexual advances at Mrs. Wood and attacked her when she rejected him.

PUBLIC NOTICES

NOTICE TO CREDITORS

North Carolina
Pitt County
The undersigned, having qualified as Executor of the Estate of Dorothy Long Cobb, deceased, late of Pitt County, North Carolina, this is to notify all persons having claims against said estate to present them to the undersigned Executor within six (6) months from date of the first publication of this notice of same will be pleaded in bar of their recovery. All persons indebted to said estate please make immediate payment. This 16th day of April, 1976.
Charles D. Cobb, Sr.
3306 S. Memorial Drive
Greenville, N.C. 27834
Executor
Frank M. Wooten, Atty.
113 W. Third St.
Greenville, N.C. 27834
April 22, 29, May 6 and 13, 1976

NOTICE TO BIDDERS

Sale of Timber
Sealed proposals will be received by the Trustees of The Black Jack Free Will Baptist Church, Route 3, Box 325, Greenville, N.C. until 10 A.M. May 1, 1976. Immediate thereafter, at the church all bids will be opened and read for the sale of approximately 17 acres of standing timber. This timber is located across from the church on SR 1725 and goes to SR 1785. Further information may be obtained by contacting one of the Trustees. The church reserves the right to reject any and all bids.
Signed: J. C. Boyd
Louis Reel
Bobby Joe Dixon
Trustees
April 9, 11, 13, 15, 19, 22, 26, and 28, 1976

NOTICE

Having qualified as Administratrix of the estate of U. B. Toler, late of Pitt County, North Carolina, this is to notify all persons having claims against the estate of said deceased to present them to the undersigned Administratrix within six (6) months from date of the first publication of this notice or same will be pleaded in bar of their recovery. All persons indebted to said estate please make immediate payment.
This 29th day of March, 1976.
Hyacinth T. Toler
Rt. 3, Box 530
Washington, N.C.
Administratrix of the Estate of U. B. Toler, Deceased.
April 1, 8, 15, and 22, 1976

NOTICE OF SERVICE OF PROCESS

IN THE GENERAL COURT OF JUSTICE
DISTRICT COURT DIVISION
North Carolina
County of Pitt
ANNIE HOLLIS STATION
VS.
JAMES STATION
TO JAMES STATION:
Take notice that a pleading seeking relief against you has been filed in the above entitled action.
The nature of the relief sought is as follows: Absolute divorce on the grounds of one year separation.
You are required to make defense to such pleadings not later than forty (40) days after the 15th day of April, 1976, and upon your failure to do so the party seeking service against you will apply to the Court for the relief sought.
This 12th day of April, 1976.
EVERETT & CHEATHAM
By C. W. Everett, Sr.,
Attorneys for Plaintiff
P. O. Box 621
Bethel, North Carolina 27812
April 15, 22, 29, 1976

HOMES FOR AMERICANS

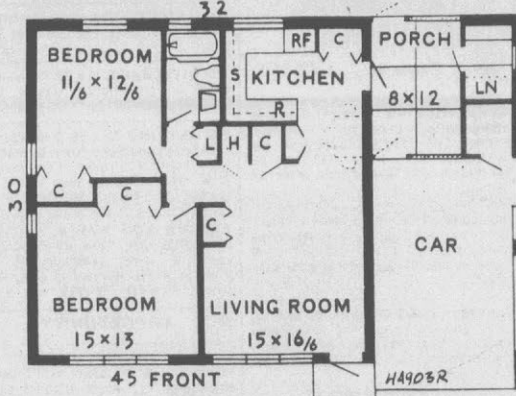
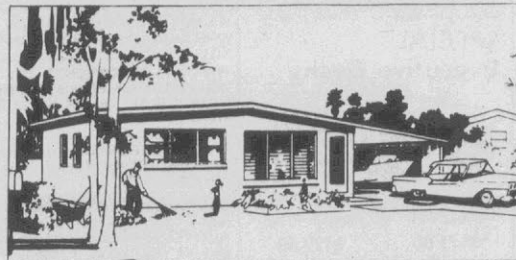

THIS COMPACT, yet comfortably livable, home was designed for a family interested in economical construction and maintenance. Designed for the era of energy crunch, all rooms are cross-ventilated, avoiding the need for air conditioning. The two bedrooms are fairly large and each has a closet with floor-to-ceiling bifold metal doors. The kitchen has room for a breakfast table. Jan Reiner, 1000 52nd Street North, St. Petersburg, Fla., 33710 is the architect of 960-square-foot Plan HA903R. Anyone wishing to know the cost of the blueprint can write to the architect, enclosing a stamped, self-addressed envelope.

WE RENT

- Baby Cribs
- Guest Beds
- T.V. Sets
- Punch Bowls

Rental Tool Co.
Dial 758-0311
3014-A E. 10th St.

COUPON

GOOD ANYTIME... DOES NOT EXPIRE

\$1.00 Off upon presentation of this coupon toward the regular price of any large or giant Pizza.

Pappi's Pizzeria

421 Greenville Blvd., Greenville, N.C.
Phone 754-0825

824 West 15th St., Washington, N.C.
Phone 946-5123

Radio Shack

BUY REALISTIC® CB!

BECAUSE 15 YEARS OF MANUFACTURING KNOW-HOW HAVE MADE US A WORLD LEADER



DELUXE REALISTIC® 23-CHANNEL MOBILE CB TRANSCEIVER

159⁹⁵ 21-145

A popular choice of avid CB'ers! Our TRC-24 features automatic noise limiter plus a noise blanker, delta-tune, lighted channel indicator, built-in modulation indicator. All crystals, mike included. Add an external speaker and use as mobile PA amplifier. Positive or negative ground. There's only one place you can find it... Radio Shack

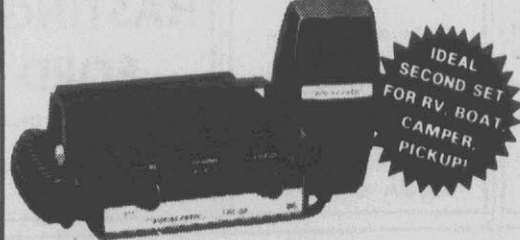

COMPACT 3-CHANNEL TRANSCEIVER

59⁹⁵ 21-139

- Call For Emergency Help On Channel 9!
- Add Crystals For Two More Channels!
- Only 1 1/2 x 4 1/2 x 6 1/2", 12 VDC Negative Ground. Mike Included!

and you can **CHARGE IT** At Radio Shack

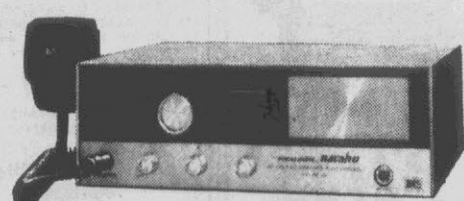

23-CHANNEL BASE OR MOBILE CB TRANSCEIVER

159⁹⁵ 21-143

- Ready To Use On Any Channel Wherever You Set Up!
- Perfect for Home, Office, Boat or Camper!
- With Mike, AC And DC Power Cords!

GET ARCHER® CB ACCESSORIES

Your friendly neighborhood Radio Shack has a complete line of famous Archer antennas, crystals, coax cables and accessories. Quality manufactured by us to assure dependable performance. Archer Brand is your brand for top value at the lowest cost. Buy your CB requisites from the CB specialists—Radio Shack!

\$100,000 IN CASH PRIZES TO BE AWARDED IN

THE 1976 REALISTIC CB SONG SEARCH™
Get Full Details at Participating Radio Shack Stores And Dealers.

42" ROOF MOUNT STAINLESS STEEL ANTENNA
18⁹⁵ 21-904

44" NO-HOLE STAINLESS STEEL TRUNK MOUNT ANTENNA
21⁹⁵ 21-908

18" GUTTER CLAMP STAINLESS STEEL ANTENNA
17⁹⁵ 21-909

SAVE \$2
102" STAINLESS STEEL BODY MOUNT ANTENNA
Reg. **12⁹⁵** 21-1094

TWIN TRUCKERS STAINLESS STEEL ANTENNA
34⁹⁵ 21-942

102" FIBERGLASS BUMPER MOUNT ANTENNA
22⁹⁵ 21-927

42" NO-HOLE FIBERGLASS TRUNK MOUNT ANTENNA
23⁹⁵ 21-926

1/2 WAVE GAIN TYPE BASE ANTENNA
24⁹⁵ 21-902

RADIO SHACK PRICES ON AVERAGE HAVE INCREASED LESS THAN 1% SINCE JULY, 1974!

GREENVILLE
PITT PLAZA SHOPPING CENTER
756-6433

Radio Shack DEALER

Most items \$99 available at Radio Shack Centers. Look for the sign in your neighborhood.

PRICES MAY VARY AT INDIVIDUAL STORES.

CLASSIFIED ADS WORK 752-6166

2 CARD OF THANKS

THE FAMILY OF Helen Powell wishes to thank our relatives and friends for the many deeds of kindness bestowed on us during our recent bereavement.

3 SPECIAL NOTICES

1. ROY P. HARRIS, will no longer be responsible for any debts contracted by anyone other than myself.

10 AUTOMOTIVE

Autos For Sale

Having Engine Trouble? See "The Engine People" Auto Specialty Co.
917 W. 5th St.
758-1131

BUICK SKYLARK 1972. 4-door, 44,000 careful miles, nice condition, factory air, \$1950. Drives excellent. 752-5193.

CAPRI 1975-1976. Air, AM-FM tape, low mileage. 20-34 EPA gas rating. Best offer over \$3500. 756-2829 - 4 and 758-5128 after 4.

CHEVELLE 1970 Greenbriar Stationwagon. \$650 firm. Call 756-0131.

CONSTRUCTION trailer with ramps, 11,000 pounds capacity. Call after 5. 752-6398.

COUGAR 1967. AM-FM, 8 track. Call 756-5555.

CRICKET 1972. 4-door, 14,000 miles. Call 758-9546 after 6.

GUARANTEED Engine, transmission, body parts. Free parts locating service.

Crisp Auto Salvage, Inc.
Phone 752-2572 N. Greene St.

DATSUN. 1974 B-210 Hatchback, 18,000 miles, FM stereo radio-tape player. Telephone 756-4252.

DODGE CORONET 1969. Yellow bottom, black top, 2-door hardtop, \$895. Must be seen to appreciate. 752-6144 after 5 p.m.

FIAT
Small Outside, Big Inside, Low on the Price Side.



America Discovers Fiat
THERE MUST BE A REASON

Brown Wood, Inc.
Dickinson Ave.
752-7111

We will buy your car for top dollar in cash or trade in allowance for good clean used cars.

FORD GRANADA 1975. 4-door, air conditioned, power brakes and steering, extra clean, 1 owner, low mileage. 756-4541 after 6.

MALIBU 1967. No engine, good for stock or super stock. Call after 5 p.m., 752-6398.

MERCURY MONTEREY 1967. Full power, vinyl roof, new tires, 1 owner car. \$625. Call 752-5909 after 7 p.m. weekdays.

PONTIAC GRANVILLE 1972. 2 door, extra clean. 756-1863.

PONTIAC GRANVILLE 1973. 2-door, 27,000 actual miles, exceptionally clean. 756-5989.

TOYOTA LAND CRUISER 1975. 14,000 miles, \$4500. 756-3794.

VEGA 1973 Stationwagon. Automatic, air conditioned, AM-FM, very good condition. Call Allan 756-1578 or 756-0088.

13 Boats For Sale

12' FIBERGLASS Sears Jonboat with Cox trailer. \$200. 746-3537 after 6 p.m.

1973 GLASSCRAFT 14', 20 HP Mercury, stick steering, lift trailer, very good condition. Call during the day 756-2882; nights or after 5 p.m., 758-4257.

1971 GRADY WHITE Stingray, 340 Chrysler Inboard. Very excellent condition. Reasonable price. 756-6820.

1972 SPORTSCRAFT. 19', 130 HP Chrysler. Power trim. Call 756-4929 after 6.

18' MAHOGANY Criss Craft. Low time on rebuilt engine, hull needs repairs, good condition. \$650. Call 752-6488.

1970 15' TRIBULL. 55 HP Johnson motor. Cox trailer. In good condition. \$1495. 756-6510 or can be seen at 10th Street Etna Station.

BOAT MOTOR. 5 HP Wizard. 756-4257 after 5.

14 Campers For Sale

1963 PACER TRAVEL trailer. 15' with air conditioner, both hot water heater and bath. Self contained. \$850. Call 752-6484 after 6 p.m.

CRISP MOBILE HOMES and Camper sale—complete catalogue sales on parts and accessories. 1974 Winnebago motor home, 3600 actual miles. \$8,999. 946-0311. 946-3416.

1973, 21' OPEN ROAD motor home. 10,000 miles, fully self-contained. 2 air conditioners, radio, tape player, outside TV Antenna, awning. Call 752-5789 after 6 p.m. Can be seen at 1300 Cotton Road.

1971 22' TRAILER. Sleeps 6, fully self-contained. Excellent condition. \$2600. 758-3434.

15 Cycles For Sale

71 HONDA 350-5L. Excellent condition. Best offer. 753-4730.

1974 HONDA CB-200. Red, good condition, best offer. 752-4288.

1974 HONDA. 1200 miles, excellent condition. \$500. 758-2300.

1973 HONDA 350 Street Scrambler. Excellent condition. \$600. 756-1498.

15 Cycles For Sale

1975 HONDA 360-T. Only 3100 miles, luggage rack, electric start, showroom condition. 756-0121 or 756-6406.

1974 HONDA Elsinore 250. Excellent condition. New tires and battery. \$500. 756-4026.

16 Trucks For Sale

1966 CHEVROLET pickup with camper. Extra clean. 758-5238.

CHEVROLET DIESEL truck tractor. Good condition. \$1200. Call 752-6488.

21 DOGS & PETS

GERMAN SHEPHERD. Male, two years old with black and tan markings. Phone 756-7256.

NEED OFFICE equipment? You'll find good buys in today's Want Ads. Check NOW!

REGISTERED AFGHAN

Hound puppies for sale. Male, \$275. Terms available. Call 758-3177 Monday to Friday after 6, all day weekends. Ask for Mrs. Gallup.

AKC REGISTERED miniature Dachshunds.

Females, \$75. Call 752-0779 after 5.

FREE: PRETTY, gentle kittens. 4 black, 2 tabby. Call 752-5580.

AKC REGISTERED Alaskan Malamute

female, 3 years old. Excellent pedigree. Great for breeding. \$250. 756-5602.

ENGLISH SETTER puppies. F.D.S.B. registered. Thor and Grouse Ridge bloodlines. 98 percent white with orange. \$75. Call 322-5149.

25 EMPLOYMENT

26 Help Wanted

PERSONS TO WAIT ON tables. Both day and night shifts. Full or part-time. Apply in person. Shoney's, 284 By-Pass.

PERSON TO WORK part time second shift at convenience store. Apply Pac-A-Sac, 1401 Dickinson Avenue.

WANTED: ALERT individual to work in parts department. We provide excellent employee benefits with opportunity for advancement. For personal interview, phone E. F. Craven Company, Bobby Daniels, 752-7145.

EXPERIENCED sewing machine operators only. 823-3174. Ask for Bobby Hudson. Apply at Tom Togs, Inc.

NEED LIVE-IN companion for elderly man to do cooking and light housework. 752-6230, 753-4713 after 6 p.m.

\$25.00 PER HUNDRED stuffing envelopes. Send self-addressed, stamped envelope. Edray Mills, Box 188LL, Albany, Mo. 64402.

BOOKKEEPER. Minimum 1 year experience, 4 day - 40 hour work week. 758-1189 Monday thru Thursday.

SALESPERSON WANTED

Apply Hastings Ford 758-0114 Ask for Brinkley Moore

SAM & DAVE'S SNACK BAR

1144 Greene Street Greenville, N.C. 27834 (Located in Darwin Waters Service Station.)

SECRETARY-BOOKKEEPER for small professional construction firm. Excellent office skills required. No shorthand. Must be over 21. Personable and enjoy meeting people. Send resume stating past salary and present salary requirements to Box 79, Greenville, N.C.

EXPERIENCED waitresses. Full time only. Apply in person, Riverside Restaurant.

RECEPTIONIST-TYPIST. No experience necessary. Send Resume. Receptionist, P.O. Box 1967, Greenville, N.C. 27834.

SALES. Orkin Exterminating Company has immediate openings in sales for the Goldsboro and Kinston area. For mature individual. Guaranteed salary, plus commission agreement. Learn while you earn. Call 523-5197 for appointment.

TAKING APPLICATIONS for full-time donut maker. Apply in person, Jerry's Sweet Shop, Pitt Plaza.

100 CLASSIFIED DISPLAY

WE BUY USED CARS
HASTINGS FORD
E. 10th St. 758-0114

ROW BUSTER PLOW
\$370.00 Plus Tax
HENDRIX - BARNHILL

Swimming Pools
Wainright Construction Co.
Greenville, N.C.
Your Swim Tech Corp. Authorized Dealer
CALL 758-3394
Demonstrators Can Be Seen

CARPET CLEANING SPECIAL
• ANY SIZE
• LIVING ROOM \$39.95
• DINING ROOM for all 3
• PLUS HALL
Call 756-3940
Offer Good Thru April

26 Help Wanted

WANTED MILK ROUTE SALESPERSON

Requirements:
High school education
Be bondable
Over 21 years of age
Knowledge of accounting
Good driving record

No phone calls please.

Apply at
MAOLA MILK & ICE CREAM CO.
109 Greenville Blvd.
Greenville, N.C.

An Equal Opportunity Employer.

RELIABLE MATURE driving sales person wanted for sales and delivery in Eastern North Carolina. No overnight travel. Salary open. Call 758-3311 for appointment.

EXECUTIVE SECRETARY position available immediately. Prior secretarial experience necessary. Minimum typing skills of 60 words per minute. Good benefits and salary. Send resume to: Position Vacancy, P.O. Box 6047, Greenville, N.C. 27834.

EXPERIENCED truck driver with chauffeur's license. Call 746-3461.

27 Work Wanted

WOMAN WOULD like to keep children in her home for working mothers. 756-6309.

TREE REMOVAL and pruning. Reasonable rates. Will negotiate. 756-7574.

INTERESTED in Babysitting. 752-7627.

DENNIS ELECTRIC Company. We install roof ventilators. Avoid the rush. Call us now. 752-8431.

FURNITURE REPAIRS. Antiques a specialty. 756-2506.

WOMAN WOULD like to keep children in her home, prefer toddlers. 758-0121.

30 FOR SALE

32 Garage-Yard Sale
104 CANDLEWOOD Drive, Oakdale. Saturday, April 24, 8 a.m. Furniture, toys, tape player, many items. Two families.

50 FAMILY GARAGE SALE. All household items, baby furniture, baked goods, plants and a bathroom sink. Saturday, April 24, starts at 10 a.m., Eastern Pines old fire department, follow the signs. Rain date May 1.

203 NORTH EASTERN. Saturday, April 24, Starts 10 a.m. Furniture, rugs, lamps, clothes, books, games, camping equipment and tent. Rain or shine.

SATURDAY, April 24 rain or shine. 9 until. Loads of odds and ends, few clothes, 2133 Memorial Drive.

YARD SALE Saturday, April 24, 2 families, clothes included. 1614 East Wright Road.

33 Heavy Equipment
CATERPILLAR DOZER. D6BU. Hydraulic angle blade, under carriage 90 percent good, oil clutch, good condition. 756-2980.

INTERNATIONAL TD15B. Hydraulic angle blade, power shift transmission, good condition. 756-2980.

CATERPILLAR. D6C dozer, hydraulic blade with fill, under carriage 90 percent good. Good condition. 756-2980.

35 Miscellaneous For Sale
PIANOS TUNED, \$25. Beacon Piano Company, 756-7166.

WANTED — wood furniture to refinish, quality work at reasonable prices. Winterville Refinishing, 758-0488 or 756-4438.

REALISTIC tape player with speakers. New \$65. Call 752-3425.

TWO OAK CHAIRS, \$10 each. 4 drawer chest, \$22. Oak center table, \$18. Pine towel rack, \$22. Oak dresser, \$45. Black Jack Antiques. 752-0312.

TR-6 1973. REAL CLEAN, excellent running condition. 752-9834.

40 GALLON complete aquarium with stand and all accessories. Will sacrifice. 756-0796.

NEED FURNITURE? We have it! Brands you'll recognize. Financing available to fit your needs. Home Furniture Store, 701 Dickinson Avenue.

WE ARE BEAUTYREST head-quarters bedding and hide-a-beds. Home Furniture Company, 701 Dickinson Avenue.

100 CLASSIFIED DISPLAY

35 Miscellaneous For Sale

FILL DIRT builder sand, top soil, and rock. J.L. McDaniel, day, 752-2382; night, 756-2351.

55 GALLON drum with gasoline pump. 756-4257 after 5.

TOBACCO PLANTS FOR SALE. Premium quality tobacco plants since 1942. Leading varieties available March 10 through June 10. See or call W.S. Bowen Tobacco Plant Farm for early booking of '76 crop. Route 3, Box 3245, Blackshear, GA 31516. Phone (912) 449-7823.

YOU CAN "STEAM" clean carpets, professionally clean with new portable Rinse-N-Vac. Rent at Rental Tool Company across from Hastings Ford. Now open — Rental Tool Company.

NCR MODEL 24 2 total cash register. \$50. Stop Shop, 752-6366.

STRAWBERRIES for sale. Pick your own. Carl Crawford Farm, 5 miles west of Greenville on 264. Turn first road to left after passing Piney Grove Church and go 1/2 mile.

35 GALLON aquaria set up. All glass tank, wood trim, glass top, light, gravel, fish, plastic plants. \$30. 756-1902.

USED RESTAURANT equipment. Excellent condition. Bum's Restaurant in Ayden. 746-6880.

FILL DIRT, top soil, rocks and sand for sale. Large loads. Henry Worthington, 746-3461.

PERSONS INTERESTED in obtaining information from present generation related to genealogical facts about Jeremiah, Joel, John and Isaac Wingate; Dennis and Samuel Cannon; Joseph Jackson. Write Mrs. Alton Lockett, P.O. Box 23, Slaton, Texas 79364.

1975 16' FIBERGLASS canoe; excellent condition, \$135. Complete set of Gary Player golf clubs; with bag, deluxe model cart, ball retriever, balls and club covers. Like new set, used only six times. \$195. Call Bonnie Pope at 752-6166 before 5 p.m.

CLEAN RUGS like new. Soeasily, with Blue Lustre. Rent shampooer, \$2. Rental Tool Company. Now open.

UPRIGHT PIANO in good condition. Call 752-4025 after 2 p.m.

SPECIAL Executive Desks
60"x30" beautiful walnut finish. Ideal for home or office.
Reg. Price Special Price
\$175.00 \$122.50

TAFF OFFICE EQUIPMENT
569 S. Evans St. 752-2175

DIAMOND RING. 1/2 carat diamond mounted in 14 carat white gold four prong. Call 753-2121, or 753-1255 on weekends and weeknights after 10 p.m.

KARASTAN Oriental rugs, 9 x 12 and 6 x 9; 2 brown wing-back chairs, loose cushion sofa; walnut antique wine cabinet. 752-7111 before 6 and 756-6248 after 6.

LARGE LOADS of sand, top soil, fill dirt and rock sold at reasonable prices. Lots cleared and debris hauled away. Call 756-4742 after 6 ton Jim Hudson.

PROTECT YOUR INVESTMENT. Steam clean your carpet with Steamex from Larry's Carpetland, 3010 East Tenth Street. 758-2300.

HOOVER CLEANERS will preserve and prolong the beauty and life of the carpet. See Smith Electric Company for sales and service. 415 Evans Street.

EXCLUSIVE dealer for Karastan Oriental rugs and carpet. Home Furniture Store, 701 Dickinson Avenue.

41 LOST AND FOUND
LOST: Black Lab puppy, 15 weeks old. Lost in Greenway Apartments. Reward offered. 756-3931 after 11 p.m.

LOST: BLACK glasses, 5th or Cotanche. Reward \$5. Call 758-5742.

45 MOBILE HOMES
46 Mobile Homes For Rent
12 x 57. 2 BEDROOMS, washer, dryer, air conditioned. Azalea Gardens. 752-7786.

100 CLASSIFIED DISPLAY

46 Mobile Homes For Rent

2 BEDROOMS, furnished. \$75. Call 756-2841, ask for Ernest Spear in Appliance Department.

12' WIDE 2 BEDROOMS, furnished, washer, air conditioned, paved patio, shady lot, no pets. 752-5907.

12 x 40. 3 BEDROOMS, furnished mobile home. On private country lot. 746-6537 after 7 p.m.

12 WIDE MOBILE home. Furnished with air conditioning from \$85 up. Also 1 2-bedroom, \$75. No pets. 758-3644.

40 x 12. 2 BEDROOM mobile home, central air conditioning. 758-4088.

8 x 35. SUITABLE for 1 person. \$90 a month. Air conditioned. Fair condition. Lawson's Trailer Park. 758-4413 or 758-2525.

MOBILE HOME spaces. City water, city sewage, swimming pool, paved street: underground utilities, recreation area. Mobile homes for rent. 758-4413.

FOR RENT OR SALE. 2 bedrooms, completely furnished on private lot. 752-8420.

TWO BEDROOMS, washer and dryer, central air, furnished or unfurnished, private lot, 2 miles out of city limits. Available May 1. 756-7821 after 5.

THREE BEDROOM trailer for rent. Air and washer. 754-7317 Thursday and Friday after 4:30 and Sunday all day.

47 Mobile Homes For Sale
12 x 45 RITZCRAFT 3 bedrooms, central air, furnished. Pay equity and assume payments; unfurnished, just assume payments. 758-4857.

PRICED TO SELL. 1976 64 x 12 Homelite, 3 bedrooms, 1 1/2 baths, better than new condition, owner buying new home. 756-6829, 752-3677 or 752-4382.

11973 CHAMPION MOBILE HOME. 65 x 12, 3 bedrooms, 2 baths, central air, screened porch, pier on canal leading to river at Swann Point, Washington, N.C. Rent on lot paid to November; price \$8900. Call 752-2175 days or 752-4029 nights.

10 x 50. 2 BEDROOM trailer. New air conditioner and new carpet. 746-3788.

1972 TAYLOR CORONET 12 x 45. total electric, special sale price \$5695. Completely set up. 758-4413 or 758-2525.

12 WIDE. 2 BEDROOMS, completely furnished, air conditioned, washer. Call 758-2670.

BACHELOR PAD. 1 bedroom, furnished, on lot. Pay small equity and take over payments. Payment plan on only \$95.45 a month. T.N. Bland, 756-3180, 756-6747.

1972 MASCOT. 3 bedrooms, 1 1/2 baths, take up payments. 756-3355 after 5:30 p.m.

1969 RITZCRAFT. 12 x 50. Furnished, double air conditioned, washer. Call 752-9432 after 7.

56 SKYLINE 12 x 55. 2 bedrooms, excellent condition, fully furnished. Moved within 25 miles of Greenville. \$1310. Must arrange own financing. Tri-County Homes, 756-0131.

BEFORE YOU BUY or sell your home, contact Colonial Park. We have a wide selection of re-manufactured homes at low, low prices. 758-4413, 758-2525.

50 OPPORTUNITY
HOUSE ZONED business or residential. \$1000 down. Will finance balance at 7 1/2 percent. Nice lot, good possibilities. Improvements needed. 108 Albemarle Street, across from College View Cleaners. Call D.G. Nichols, 752-4585.

3 BEDROOM house with den, located 509 West Third, Greenville. Priced right with good financing. See Jimmy Brewer or call Hooker and Buchanan 752-6186.

BY OWNER. 2 story, 3 bedrooms, 1 1/2 baths, 1800 square feet, lot and a half, canal access to river. 946-7560 or 752-2588.

BY OWNER. 7 room house on large corner landscaped lot. 816 square feet of outside storage plus double carport. Low 30's. Call 746-3221 after 6.

113 FAIRLANE ROAD. 3 bedrooms, 2 baths, formal dining, family room, kitchen combination, garage and greenhouse plus carport. \$43,500. Bill Williams Real Estate, 752-2615.

IN CHERRY OAKS. 3 bedrooms, 2 baths, fully everything, approximately 1800 square feet, excellent condition, wooded lot, good financing. Call days 752-5175, night 756-5575.

100 CLASSIFIED DISPLAY

AVAILABLE in Rocky Mount
HONDA CIVIC \$2739
From P.O.E.
DAVENPORT MOTOR COMPANY
900 S. Church St. 446-7161

51 PROFESSIONAL
R.C. WATERS Construction Company. Room additions, remodeling, and masonry work. Call 756-6765 or 756-4391.

55 REAL ESTATE
LET WEDCO REALTY do your leg work. We are concerned about your housing needs. Call 756-1395.

50 OPPORTUNITY

MOBILE HOME REPAIR business for sale. Included 1971 F-100 Ford pickup, tool boxes, shell, all necessary tools. 752-7548 after 5 p.m.

BICYCLE BUSINESS for sale. Tires, parts and accessories. \$600. Call 756-2557 8 a.m. till 5:30 p.m.

51 PROFESSIONAL
R.C. WATERS Construction Company. Room additions, remodeling, and masonry work. Call 756-6765 or 756-4391.

55 REAL ESTATE
LET WEDCO REALTY do your leg work. We are concerned about your housing needs. Call 756-1395.

Buying or Selling, For Best Results Try OUR "Personal Service."

D.G. NICHOLS AGENCY
REALTOR Phone 752-4012 anytime.

Nelson-Wallace Real Estate

CHARLIE SPEIGHT
Sales Associate
Farm and Commercial Property Specialist
Office 752-5113 Home 752-6351

For Better Buys In Real Estate Call or See E. H. Williford
List Your Property With Us
222-B Cotanche, P.L.#3911
Night PL 2-4409

HOUSE ZONED business or residential. \$1000 down. Will finance balance at 7 1/2 percent. Nice lot, good possibilities. Improvements needed. 108 Albemarle Street, across from College View Cleaners. Call D.G. Nichols, 752-4585.

3 BEDROOM house with den. located 509 West Third, Greenville. Priced right with good financing. See Jimmy Brewer or call Hooker and Buchanan 752-6186.

BY OWNER. 2 story, 3 bedrooms, 1 1/2 baths, 1800 square feet, lot and a half, canal access to river. 946-7560 or 752-2588.

BY OWNER. 7 room house on large corner landscaped lot. 816 square feet of outside storage plus double carport. Low 30's. Call 746-3221 after 6.

113 FAIRLANE ROAD. 3 bedrooms, 2 baths, formal dining, family room, kitchen combination, garage and greenhouse plus carport. \$43,500. Bill Williams Real Estate, 752-2615.

IN CHERRY OAKS. 3 bedrooms, 2 baths, fully everything, approximately 1800 square feet, excellent condition, wooded lot, good financing. Call days 752-5175, night 756-5575.

100 CLASSIFIED DISPLAY

AVAILABLE in Rocky Mount
HONDA CIVIC \$2739
From P.O.E.
DAVENPORT MOTOR COMPANY
900 S. Church St. 446-7161

CRAFTED SERVICES
Quality Furniture Refinishing and Repairs. Superior Care for all type chairs. Larger Selection of Custom Picture Framing. Survey Stakes — Any length, all types of pallets. Hand-crafted rope hammocks. selected framed reproductions.

Eastern Carolina Sheltered Workshop
Industrial Park Hwy. 13
758-4188 8 a.m.-4:30 p.m.
Greenville, N.C.

IT'S TIME TO TRADE
THURSDAY SPECIAL
1969 GMC CARGO VAN
6 cylinder, standard drive, paneled, carpeted. A-1 condition.
\$1490.

Goodman Auto Sales
3004 S. Memorial Dr. 756-6353
(Adjacent to Edwards Motor Co.)

ANTIQUE AUCTION SALE
Friday Night, April 23 at 7 P.M.
Selling Over 800 Items Including:

Walnut, Walnut Marble Top, Primitive, Oak, Mahogany Furniture, Lots of Nippon, Varrian and Other Old China. Cut, Pressed and Depression Glass.
Merchandise May Be Inspected All Day Friday Prior To Sale.

HAWLEY'S ANTIQUE AUCTION
Owner-Auctioneer Col. George T. Hawley
N.C. Licenses Number 76
P.O. Box 104 Highway 903
Stokes, N.C. 27884
Phone 758-2861

58 Houses For Sale

UNIVERSITY AREA. 120 North Woodlawn. Good investment property or perfect for the couple who wants an older home to fix up. Three bedrooms, family room, hobby room, 1 bath. Located on corner lot for \$18,500. Estate Realty Company, 752-3058. Nights - 756-7222, 752-3647 or 756-4652.

HOUSE ZONED business or residential. \$1000 down. Will finance balance at 7 1/2 percent. Nice lot, good possibilities. Improvements needed. 108 Albemarle Street, across from College View Cleaners. Call D.G. Nichols, 752-4585.

3 BEDROOM house with den, located 509 West Third, Greenville. Priced right with good financing. See Jimmy Brewer or call Hooker and Buchanan 752-6186.

BY OWNER. 2 story, 3 bedrooms, 1 1/2 baths, 1800 square feet, lot and a half, canal access to river. 946-7560 or 752-2588.

BY OWNER. 7 room house on large corner landscaped lot. 816 square feet of outside storage plus double carport. Low 30's. Call 746-3221 after 6.

113 FAIRLANE ROAD. 3 bedrooms, 2 baths, formal dining, family room, kitchen combination, garage and greenhouse plus carport. \$43,500. Bill Williams Real Estate, 752-2615.

IN CHERRY OAKS. 3 bedrooms, 2 baths, fully everything, approximately 1800 square feet, excellent condition, wooded lot, good financing. Call days 752-5175, night 756-5575.

100 CLASSIFIED DISPLAY

AVAILABLE in Rocky Mount
HONDA CIVIC \$2739
From P.O.E.
DAVENPORT MOTOR COMPANY
900 S. Church St. 446-7161

CRAFTED SERVICES
Quality Furniture Refinishing and Repairs. Superior Care for all type chairs. Larger Selection of Custom Picture Framing. Survey Stakes — Any length, all types of pallets. Hand-crafted rope hammocks. selected framed reproductions.

Eastern Carolina Sheltered Workshop
Industrial Park Hwy. 13
758-4188 8 a.m.-4:30 p.m.
Greenville, N.C.

IT'S TIME TO TRADE<

66 Apartments For Rent

NEW DUPLEX apartment, 2 bedrooms, on Stantonburg Road. Available May 1. Couple desired. 756-7821 after 5.

APARTMENTS for rent. 746-3284.

NICE FURNISHED APARTMENT. Carpeted, air conditioned, one block from university, married couples only, no pets. 752-2430.



Most luxurious 2 bedroom townhouses and 1 bedroom apartments in Greenville. Chandelier, trash compactor, fully carpeted, drapes, etc., plus washer and dryer hook-ups, fabulous pool, sauna baths, tennis court and club room. 752-1557

NEW DUPLEX. Corner of 3rd and Cedar. 2 bedrooms, fully carpeted, central heat and air, fireplace, stove refrigerator and dishwasher furnished. Call after 5. 756-5050, 5185.

ELM VILLA, 208 South Elm Street. One and two bedroom apartments, completely furnished, carpeted, central heat, air and utilities. Call 52-3376.

Eastbrook APARTMENTS

Two bedroom luxury apartments with optional dens and all the new amenities including wall to wall carpeting, draperies, dishwashers, individual air conditioning and heating AND MORE.

CALL 758-4012

100 CLASSIFIED DISPLAY

66 Apartments For Rent

Kings Row

One and two bedroom garden apartments. Located just off East Tenth Street.

PHONE 752-3519

STRATFORD ARMS APARTMENTS. 1900 Charles Blvd., Building 19. A blend of charming surroundings and quality apartments unequalled at any price. All applications accepted subject to availability. Call J.D. Reel Estate, 756-4800.



Ultimate In Apartment Living

1, 2, and 3 bedrooms, washer, dryer hook-ups, pool, club house. Only 5 blocks from East Carolina University.

Check everywhere else first, Then Call

TAR RIVER ESTATES
1401 Willow St.
752-4225



100 CLASSIFIED DISPLAY

66 Apartments For Rent



Beautiful large 2 bedroom garden apartments with wall to wall carpet, draperies, dishwasher and two swimming pools. Located off Country Club Drive adjacent to Greenville Golf and Country Club. 756-6869

68 Lots For Rent

BEAUTIFUL mobile home lots on Pamlico River. 1/4 mile sandy beach, pier and boat launch. Call days, 946-4711, evenings, 946-6236.

69 Office Space For Rent

IN BUSINESS? Make a change for the better with a new office in the centrally located Wilcar Building. Beautifully decorated offices available starting as low as \$60 a month. Janitorial services included. You can't afford to wait. Call 752-1020 today.

70 Resort Property For Rent

WATERFRONT mobile home spaces are now available for immediate leasing to owners of nice, attractive mobile homes in Atlantic Beach's newest and nicest home park. North Shore Mobile Home Park, A.B. Cooper, Jr., P.O. Box 99, Atlantic Beach, N.C. 28512. 726-2865, 726-8669.

SAVE TIME, save effort and save money, too, by shopping the Classified Ads in The Daily Reflector first to find the things you want.

COTTAGES FOR RENT at Atlantic Beach, Morehead. 726-3884 or 746-3284.

75 WANTED

USED INFANT car seat, prefer Peterson, Bobby Mac or GM. 758-4650.

ONE TO THREE acres land, partially wooded, within 6 miles of Greenville. 758-5013 after 5:30, anytime weekends.

TOP CASH DOLLAR for your car or truck. 756-6353 or 752-0391.

The Real Estate Corner REDUCED!!

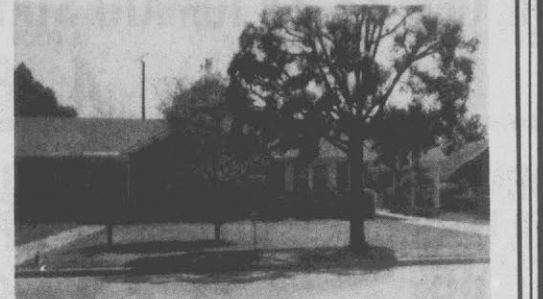

~~\$57,500~~ \$55,500

Make an appointment to see the inside of this lovely, spacious home with 3 bedrooms, 2 baths, foyer, living room, dining room, kitchen with eat-in area. One of the better-built homes in this area. The extras include a double garage, another carport, central air conditioning and heat.

Another good buy! Two neat, well-built buildings. Could be used for church, store, garage, home or apartments — Only \$30,000.

LET US LIST YOUR PROPERTY FOR QUICK SALE MEMBER OF MULTIPLE LISTING SERVICE

J. L. Harris & Sons
Realtor

PAINTING PROPERTY MANAGEMENT REPAIRS

204 W. 10th STREET
PHONE 758-4711

Jean Perkins 752-6396
Florence (Bebe) Teel 752-6324

3 YEARS OR 100,000 MILES WARRANTY ON THE PURCHASE OF A NEW TOYOTA

RECORD BREAKING SALE

WE'RE GOING TO SELL 200 NEW TOYOTAS FROM NOW UNTIL MAY 30.

DON'T BE ONE TO MISS THIS GOLDEN OPPORTUNITY TO PURCHASE THE TOYOTA OF YOUR CHOICE.

12 MONTHS OR 12,000 MILES USED CAR WARRANTY

Most good used cars, if they're guaranteed at all, are only covered for a month or two. At Tarheel Toyota, we're just as willing to back our good used cars as our good new cars. So we guarantee the motor, transmission and rear end for 12 months or 12,000 miles. This warranty applies to all cars selling for more than \$1000.00 or more on a 50-50 basis with all work being done in our shop. It doesn't apply to any sports cars, high performance engines or 4 speed transmissions (except economy cars). If you're in the market for a BETTER USED CAR, COME OUT AND LOOK AT OURS. We'll show you some as good as new. Guaranteed. (Owners name furnished upon request.)

SPECIAL THIS WEEK!	
1975 SUZUKI "500" High rise bars, sissy bar, crash bars, only 850 miles. Blue. Just like new. \$1298	1971 VOLKSWAGEN 411 4 door. Automatic, radio, heater, local car. \$1398
1972 MERCEDES 220 4 door. Automatic, air, power steering and brakes. Light blue. \$5998	1974 PONTIAC LeMans. 2 door hardtop. Medium blue with vinyl top. Low mileage, automatic, air condition, radio, heater. Extra nice. \$3398
1973 PORSCHE 914 Lime Green, radial tires, 5 speed, removable hardtop, excellent condition, clean. \$4998	1971 MGB GT Radial tires, 4 speed, AM-FM radio, fender in color. Brand new engine. \$2998
1975 TOYOTA Celica GT. 5 speed, air, AM-FM stereo, radial tires, extremely sharp. Only 2200 miles. \$4498	1973 DODGE Charger SE. Automatic, air, power steering and brakes, vinyl top, AM-FM stereo tape, brown. \$2998
1974 OLDS Cutlass Supreme. Green, automatic, air, radio, heater. \$3998	1974 MAZDA RX-3 Wagon. Automatic, air, AM-FM tape player, green. \$2898
1974 OLDS Cutlass Supreme. Brown with vinyl top, automatic, air, radio, heater clean. \$3998	1974 VOLKSWAGEN Beetle. 4 speed, radio, heater, orange, real nice. \$2898
1974 TOYOTA Mark II. 2 door hardtop, automatic, air condition, power steering and brakes, vinyl top, radio, heater, clean. \$3798	1974 TOYOTA Corolla SR-5. 2 door. Radio, air condition, brown metallic. \$2898
1972 TOYOTA Landcruiser Stationwagon. 4 door, radio, heater, standard transmission, 4-wheel drive, wire hubs, extra low mileage, blue and white color. \$3798	1973 TOYOTA Hilux. 4 speed, radio, heater, clean. \$2698
1974 TOYOTA Celica GT. 5 speed, air, rear spoiler, AM-FM, brown metallic, vinyl top. \$3798	1974 GREMLIN Automatic, radio, heater, extra clean, silver blue. \$2598
1974 MALIBU Classic. 2 door. Automatic, air condition, AM-FM radio, heater, vinyl top. \$3598	1974 FORD Pinto. Automatic, radio, heater, red, nice car. \$2498
1974 CHEVROLET Impala Custom. 2 door hardtop, AM-FM stereo, air, tilt wheel, cruise control, power windows, chocolate brown, tan top. \$3598	1973 BUICK LeSabre. 2 door. AM-FM radio, air condition, power steering and brakes. \$2498
1975 CHEVROLET Monza. 2 door hatchback, blue, 4 speed, radio, heater, air condition, 3,000 miles, like new. \$3598	1974 CHEVROLET Vega. Radio, heater, 4 speed, canary yellow, nice car, clean. Stock No. D-2825-A. \$2398
1974 CHEVROLET Cheyenne Pickup. Automatic, radio, heater. \$3498	1974 CHEVROLET Vega. 2 door. Brown with white stripe, AM-FM radio with tape, sport rims. Stock No. 2708-A. \$2298
1974 CHEVROLET 1/2 ton pickup. Automatic, power steering and brakes, tool box. Blue and white. \$3498	1973 TOYOTA Hilux. 1/2 ton, short bed, 4 speed, heater. \$2398
	1972 CHEVROLET Heavy Chevy. 2 door hardtop. Blue with black interior, V-8, standard shift, radio, heater. \$2298
	1971 CHEVROLET Monte Carlo. Automatic, air, radio, heater, brown metallic with brown vinyl top, radial tires. \$2298
	1971 BUICK Skylark. Automatic, radio, vinyl top, air, green. \$2198
	1971 MGB 4 speed, radio, heater, convertible top. Fire engine red. \$2198
	1973 TOYOTA Corona Wagon. Automatic, air, AM radio, heater, brown. \$2198
	1973 AMC HORNET 2 door. Brown, 3 speed transmission, radio, heater. \$2198
	1972 TOYOTA CORONA 4 door. 4 speed, radio, heater, air, light blue. \$2098
	1972 DATSUN 510 Wagon. Automatic, radio, heater, vinyl top. \$1998
	1973 FIAT 128 White, 4 door, 4 speed, front wheel drive, AM radio. \$1898
	1971 BUICK Estate Wagon. Automatic, air condition, full power, AM-FM radio, tilt wheel, super buy. \$1798
	1972 PLYMOUTH Duster. Automatic, radio, heater. \$1798
	1971 PONTIAC LeMans. Automatic, power steering and brakes, air condition, radio, heater, brown. \$1798
	1971 CHEVROLET Chevelle. Automatic, radio, heater, power steering, brilliant yellow with black top. \$1798
	1973 CHEVROLET Vega GT. 4 speed, AM radio, heater, brown. Stock No. D3056-A. \$1798
	1973 CHEVROLET Vega. 2 door hatchback, automatic, radio, heater, brown. Stock Number 2887-A. \$1798
	1972 SUBARI Stationwagon. 4 speed, AM-FM radio, gold with black vinyl top. \$1698
	1968 CHEVROLET Chevelle Automatic, power steering, tape player, FM converter, vinyl top, light blue, mag wheels, just like new. \$1598
	1970 BUICK Skylark. 4 door sedan, automatic, air, power steering, silver. \$1498
	1971 PLYMOUTH Duster. Automatic, air condition, radio, heater clean. \$1498
	1969 PONTIAC GTO. Automatic, air condition, power steering and brakes, radio, heater, bucket seats. \$1298
	1971 CHEVROLET Vega. Green, 4 speed, radio, heater. Stock No. 2984-A. \$1198
	1969 PONTIAC LeMans. 2 door. Silver grey. \$998
	1968 FORD LTD Automatic, AM-FM radio, air, blue with black vinyl top. \$998
	1969 OLDS 98 4 door. Vinyl top, automatic, air condition, radio, heater, clean. \$898
	1968 FORD Fairlane. 6 cylinder, 3 speed, air condition, radio, heater. \$898
	1969 CHEVROLET Impala. 4 door hardtop, automatic, air condition. Blue with white top. \$898
	1967 CHEVROLET Impala. 2 door. AM radio, power steering. \$798
	1965 FORD Pickup. 1/2 ton. Green, straight drive. Radio, heater. \$798
	1967 DODGE 4 door. Green, automatic, radio, heater. \$698

1966 Ford
4 door. Dark blue.
\$498

TARHEEL TOYOTA
109 Trade St. - Phone 756-3228 - Greenville
"Your Authorized Toyota - Mercedes Dealer"
OPEN WEEKDAYS TIL 8 P.M. - SATURDAYS TIL 5 P.M.

1961 Volkswagen
4 speed, radio, heater.
\$498

HOLT'S 7 BEST BUYS

- '75 PONTIAC LEMANS COUPE
Air condition, 1 owner. \$4195.
- '74 DATSUN 260Z
Air condition, 4 speed. \$5795.
- '74 CHEVROLET CAMARO
Air condition, like new. \$3995.
- '74 MGB CONVERTIBLE
Like new. \$3995.
- '74 CHEVROLET MONTE CARLO
Cream with beige top. Air condition, 1 owner. \$4195.
- '75 FORD LTD BROUGHAM
4 door, air condition. Blue with white top. \$3895.
- '73 TOYOTA COROLLA
2 door, air condition. 27,000 miles, clean. \$2350.

HOLT OLDS-DATSUN
101 Hooker Rd. 756-3115

Spring Fever? Yes!!!

At Phelps Chevrolet

How About This For A Sleeper?

1976 Chevrolet Chevette
Stock no. 508
\$2941.47 plus tax

34 Chevettes, Monzas And Vegas In Stock.

On most of our 1976 Monzas and Vegas, the first \$200.00 worth of options cost you only \$19.76.

We've got to sell 30 of these models this month. Savings may never be greater at Phelps Chevrolet during this 1976 sale.

PHELPS CHEVROLET

Sales Representatives
Rex Wainwright Regan Jones
Jimmy Pace Ed Briley
Clyn Barber Jay Mills

W.D. Phelps, President
Norman VanHorne, Sales Manager
James Phelps, Used Car Manager

West End Circle Open 8 A.M. to 7:30 P.M. Phone 756-2150

British Curb On Pine-Tree Cutting Sparked Revolt

By KARL SWANSON
Associated Press Writer
WEARE, N.H. (AP) — Three years before the Minutemen fired the "shot heard round the world," a band of woodsmen from this southern New Hampshire town struck their first blows against British rule.

On April 14, 1772, the men forced their way into tavern rooms rented to a king's sheriff and his deputy and nearly beat them to death with switches.

The event has become known as the Pine Tree Riot.

The trouble began earlier that year when woodsmen illegally cut into the king's prized lots of white pine. The logs, as straight and true as most Englishmen had ever seen, were stored in several mills in the Weare area.

Since 1690 the white pines in New Hampshire had been reserved for masting ships of the Royal Navy. They were coveted for their size and strength by the British government, which claimed them for the exclusive use of the Crown.

The colonists, however, wanted the trees themselves for use in building and furniture making. Thus were drawn the lines of conflict in one of the earliest acts uniting the people of New Hampshire against King George.

When British authorities discovered the store of logs, the mill owners were ordered to show cause why the timber should not be confiscated and the cutters fined.

The mill owners responded with diplomacy. They sent Samuel Blodgett of Gossetown on the 40-mile journey to Portsmouth to negotiate with Gov. John Wentworth.

Realizing a potential ally, Wentworth turned the tables and appointed Blodgett a "deputy surveyor of the king's woods."

Returning to Weare, Blodgett sent his former employers a letter explaining that as the new deputy surveyor he would have to enforce the law; but he would be loath to turn on his neighbors "unless obstinate or notorious offenders" should force him.

Blodgett ordered the cutters to pay a fine, and 17 of them agreed. Only the men from Weare held out.

On April 12, Sheriff Benjamin Whiting, accompanied by a deputy, went to Weare to arrest the recalcitrants. The next day he arrested one offender, Ebenezer Mudgett, and ordered him to post bail. Whiting then retired to a local inn for the night.

News of the sheriff's arrival had spread through the town. At a meeting that night in Mudgett's house, the colonials decided to post their compatriot's bail, but not in a form the sheriff would relish.

When dawn broke on April 14, Mudgett roused Whiting, claiming he had come with his bail money. The sheriff, still in his nightclothes, opened the door to his room, and 20 men, their faces blackened and switches in hand, pounced on him and beat him.

The deputy, awakened by the commotion, locked the door to his room. Not to be denied, the woodsmen ripped their way in and beat him.

Others prepared the lawmen's departure. Their horses, with ears cropped and manes and tails clipped, were brought to the scene and the king's men were forced to mount. They were sent on their way with "the sound of jeers and shouts ringing in their ears," one account reads.

Arriving in Derryfield, now the City of Manchester, Whiting summoned the aid of the British militia. Armed with muskets, the soldiers marched to Weare, but the rioters had long since fled to the forest.

Whiting, his wounds still

smarting, did not let the matter rest. He finally caught one of the rioters and sent him off to jail. By September seven others

had been indicted. They pleaded guilty and were ordered to pay fines of 20 shillings each and the costs of the prosecution.

The light fine for such an outrageous offense, some historians note, indicated the "court

had more sympathy for the men who cut the logs and regard for public sentiment, than later other colonists would take up arms at Lexington in opposi-

tion to the Stamp Act, the Sugar Act and excessive duties on tea. For the people of New Hampshire — who relied on

lumber for their livelihood — the pine tree law had already proven to be oppressive enough to spark rebellion.

JOIN ECKERD'S SENIOR CITIZENS PLAN - 10% Savings on all your Prescriptions - IF YOU'RE 60 OR OLDER

"Super 88" Savings Days at ECKERD DRUGS

Sweet 'n Low Granulated Sugar Substitute

100 Packets

79¢

LOOK WHAT 88¢ WILL BUY!

SCHICK SUPER II CARTRIDGES PACKAGE OF 5. **88¢**

WOODEN TOMATO STAKES 6-FOOT HIGH. **4 FOR 88¢**

Lady Seymore Ironing Board

\$5.99

NEW AT ECKERD'S! CB MOBILE MONITOR & RECEIVER

EASY TO INSTALL—NEEDS NO MAJOR WIRING. ATTACHES TO SUN VISOR. FULL 23-CHANNEL OPERATION. WITH ANTENNA STRIP, CONNECTOR BLOCK.

\$19.88

FURNACE FILTERS 4 POPULAR SIZES. **2 FOR 88¢**

REYNOLDS ALUMINUM WRAP 12"X25' ROLL. **3 ROLLS FOR 88¢**

LOW, LOW PRICE! SCHICK QUICK CURLS CURLING IRON

SPRAY WITH PRE-SETTING MIST. THEN CURL WITH TEFLON-COATED IRON WITH COOL TIP. SWIVEL CORD. #C1-3

\$4.88

8-OZ. ARM-IN-ARM SPRAY DEODORANT WITH BAKING SODA. **88¢**

Miss Breck Hair Spray 11 Oz. **79¢**

Gulf Lite Charcoal Starter 32 Oz. **59¢**

Vanquish Pain Formula Extra strength — gentle buffers 100's **99¢**

Rival Crock Pot

\$14.88

HERBAL ESSENCE CREME RINSE 8-OZ. REGULAR OR WITH BODY. **88¢**

2 1/2-OZ. CALADRYL LOTION FOR POISON IVY OR OAK. **88¢**

20-QT. FOAM ICE CHEST WITH MOLDED-IN HANDLES. **88¢**

ECKERD'S RAZOR BLADES PLATINUM CHROME Double Edge Blades. PACKAGE OF 10. **88¢**

GREAT BUYS ON LAWN FURNITURE

FOLDING ALUMINUM CHAIRS HAS WIDE WEBBING, FULL SIZE WATERFALL ARMS. #377. **\$9.88**

MATCHING LAWN CHAIR #774. **\$4.88**

PISTOL-GRIP HOSE NOZZLE #2970C. **88¢**

35-OZ. CALGONITE DETERGENT FOR AUTOMATIC DISHWASHERS. **88¢**

CORRECTOL LAXATIVE 30 TABLETS. **88¢**

CHAP STICK LIP BALM IN FLAVORS. **2 FOR 88¢**

BLUE LUSTRE VACUUM BAGS PACKAGE OF 5. **88¢**

Sav-A-Spill Beverage Holder For car, boat, patio, in assorted colors. **2 For 29¢**

TABLE-TOP PORTABLE BBQ GRILL DEEP BOWL, BEADED RIM, PLATED GRID WITH HANDLE—ADJUSTS TO 3 HEIGHTS. SLIDE & SNAP LEG SUPPORT EASY TO ASSEMBLE. #1708. **\$4.88**

COPPERTONE TROPICAL BLEND DARK TANNING OIL WITH NATURAL INGREDIENTS. 8-OZ. BOTTLE. **\$1.88**

QUALITY PHOTO ALBUM KEEPS YOUR FAVORITE SNAPSHOTS! KEEPS THEM NEAT, CLEAN AND ALWAYS IN PERFECT ORDER. DRY-MOUNT PAGES. VINYL BINDING. **\$1.88**

PKG. OF 100 PROMPT TABLETS FOR FAST PAIN RELIEF! **\$1.88**

300 TABLETS OF GERITOL AT BIG SAVINGS! IN LOVELY RE-USABLE APOTHECARY JAR. **\$9.88**

Talent Show At School April 29

FALKLAND—A talent show will be held at the Falkland Elementary School Thursday, April 29, at 7:30 p.m.

The charge will be 50 cents for adults and 25 cents for children. Refreshments will be available and a bake sale will be held during the intermission.

Crest Toothpaste 7 Oz. Tube **97¢**

FOSTEX CREAM SKIN CLEANSER & SHAMPOO FOR ACNE PIMPLES, BLACKHEADS, OILY SKIN, DANDRUFF. 4 1/2-OZ. JAR. **\$1.88**

Plan Woman's Day Service

BETHEL—The annual Woman's Day Service will be held at Riddick Chapel Baptist Church Sunday, May 2, at 11 a.m.

The guest speaker will be Ms. Effie B. Thompson of Greenville. The Rev. J.L. Farmer is minister of the church.

SCHOLL'S EXERCISE SANDALS EXCLUSIVE TOE-GRIP ACTION FIRMS AND TONES YOUR LEGS TO HELP MAKE THEM SHAPELIER! CHOICE OF COLORS. **\$10.88**

Auto Snack Tray & Tape Caddy FITS OVER HUMP IN CAR TO HOLD BEVERAGES AND 8-TRACK TAPE CARTRIDGES. **88¢**

SHORT-HANDLED FLOWER-VEGETABLE GARDEN TOOLS WOOD HANDLES. CHROME PLATE TOOL HEADS. WEEDER, CULTIVATOR, TROWEL, TRANSPLANTER. YOUR CHOICE: **88¢ EACH**

Auto Snack Tray & Tape Caddy FITS OVER HUMP IN CAR TO HOLD BEVERAGES AND 8-TRACK TAPE CARTRIDGES. **88¢**

Auto Snack Tray & Tape Caddy FITS OVER HUMP IN CAR TO HOLD BEVERAGES AND 8-TRACK TAPE CARTRIDGES. **88¢**

THIS IS **Eckerd's DRUG STORES** CREATORS OF REASONABLE DRUG PRICES

ECKERD'S IS A GREAT PLACE TO WORK... ECKERD'S IS AN EQUAL OPPORTUNITY EMPLOYER!

FREE 5" x 7" FULL-COLOR ENLARGEMENT... with every roll of Kodacolor film developed and printed at ECKERD'S! (5" x 5" with square negative) Plus a BIG 25% DISCOUNT on all your film processing—EVERYDAY!

You'll save more overall on prescriptions at Eckerd's than anywhere else. Ask for our free health care folders.

PRICES GOOD THRU SAT., APR. 24