

Reaction Points To Stiff Debate

Summit Talks Laid New Foundation, Says Nixon

By LEWIS GULICK
Associated Press Writer
WASHINGTON (AP) — Reporting that the Moscow summit laid the foundation for a new U.S.-Soviet relationship, President Nixon has quickly asked Congress for approval of the landmark superpower missile pact "to check the wasteful and dangerous spiral of nuclear arms."

Nixon's plea to a half-filled joint session of Congress Thursday night—where he hurried straight-away upon his return to Andrews Air Force Base—won wide praise but enough criticism to show the SALT accords will face some stiff debate.

Sen. Henry M. Jackson, a Democratic presidential contender, said Nixon had confessed to a growing Soviet momentum in missileery. Rep. John M. Ashbrook, a Republican presidential hopeful, said

the strategic-arms agreements would allow the Soviets a big advantage.

But Sen. Robert P. Griffin of Michigan, the assistant Senate GOP leader, reflected what appeared to be more-widespread, favorable reaction in saying:

"The President presented Congress with a challenge to build on a solid foundation he has prepared. Surely, the first order of business for Congress should be to indicate support by

ratifying the accords reached at Moscow."

Nixon called congressional leaders to the White House today before heading for a Florida vacation. The SALT treaty on limiting defensive antiballistic missiles—ABMs—requires a two-thirds Senate vote, while the accompanying executive agreement curbing offensive missiles can pass with a majority in the Senate and House.

Only 48 of 100 senators and

fewer than 200 of the 433 House members showed up to hear Nixon as the President, upon returning from his 13-day journey, transferred directly from his jetliner to a helicopter and hopped to Capitol Hill.

"The foundation has been laid for a new relationship between the two most powerful nations on earth," Nixon reported to the unusual joint session in his nationally broadcast, half-hour address.

"Now it is up to us—to all of us here in this chamber and to all of us across America—to join with other nations in building a new house upon that foundation—one that can be a home for the hopes of mankind and a shelter against the storms of conflict."

Referring to his Peking trip in February as well as his meeting with Soviet leaders, Nixon declared "the summits of 1972" are "part of a great national journey for peace."

While deep philosophical differences persist and the threat of war has been reduced but not eliminated, he said, historians will record 1972 as "the year when America helped to lead the world up out of the lowlands of constant war, and onto the high plateau of lasting peace."

Nixon recited the range of agreements on space cooperation, joint medical efforts and other accords announced at Moscow and predicted the new U.S.-Soviet Joint Commercial Commission will reach a comprehensive trade agreement later this year.

"And most important," he said, "there is the treaty and related executive agreement which will limit, for the first time, both offensive and defensive strategic nuclear weapons in the arsenals of the United States and the U.S.S.R."

Mustering arguments against conservative critics of the missile accords, Nixon continued: "Three-fifths of all the people alive in the world today have spent their whole lifetimes under the shadow of nuclear war which could be touched off by the arms race among the great powers...."

"With this step we have enhanced the security of both nations. We have begun to check the wasteful and dangerous spiral of nuclear arms which has dominated relations between our two countries for a generation."

"No power on earth is stronger than the United States of America today," he said. "None will be stronger than the United States of America in the future."

Critics say the ABM treaty, which limits the United States and the Soviet Union to two ABM sites each, and the offensive-missiles agreement, which imposes ceilings on numbers of long-range rockets at existing levels, will hand the Soviets a wide and unbeatable missile margin.

Nixon made brief mention of his "heartwarming welcome in Warsaw"—the last stop in his four-nation trip which also included Austria and Iran—and went into little detail on some major aspects of his week-long talks with Soviet Communist party chief Leonid Brezhnev.

He acknowledged that "the problem of ending the Vietnam war... was one of the most extensively discussed subjects of our agenda."

But he said "it would only jeopardize the search for peace" if he were to report more than that "each side obviously has its own point of view."

Will Tabulate

The Daily Reflector will tabulate returns from Saturday's second primary election.

Poll holders are reminded to phone the newspaper office, 752-6166, as soon as results are available.

A Second Opportunity

Polling places for tomorrow's second primary election will open in Pitt County at 6:30 a.m. and remain open until 7:30 p.m. to give registered voters a second opportunity to select nominees to four state offices.

Republicans will be voting on their choice of nominees for the office of governor. The winner of the race—either James C. Gardner or James E. Holshouser—will face the Democratic nominee in the November general election.

Likewise tomorrow, Democrats will be voting for their choice of nominees for Governor, either H. P. "Pat" Taylor or Hargrove "Skipper" Bowles.

Democrats will also choose nominees for the

office of United States Senator, Commissioner of Insurance and Commissioner of Labor.

Competing for the Democratic Senate nomination are incumbent Sen. B. Everett Jordan and hopeful Congressman Nick Galifianakis.

Competing against each other for the Commissioner of Insurance nomination are John Ingram and Russell Secrest, while facing each other in the race for Commissioner of Labor are John C. Brooks of Greenville and W. C. Creel.

There are 26 precincts in the county and 31,606 registered voters. Included in the list of individuals registered are 27,119 Democrats and 3,883 Republicans.

Food Prices Surge As Job Index Firm

WASHINGTON (AP) — A new surge in food prices pushed up wholesale prices faster last month than in March and April, while the nation's unemployment rate remained unchanged at 5.9 per cent.

The Bureau of Labor Statistics said today farm products rose 1.4 per cent in May after declining the two previous months. Largely as a result of that, wholesale prices of all commodities rose 0.6 per cent after slight increases the two

months before. The nation's jobless rate failed to show any improvement despite a slight increase in the total number of persons holding jobs. The bureau said 5.9 per cent of the work force was still looking for jobs, the same percentage as in April and March.

The wholesale price news appeared to spell a setback for President Nixon's program of wage and price controls.

The wholesale price index

rose 0.6 per cent, or 0.5 per cent on a seasonally adjusted basis.

One encouraging note was the index of industrial commodities, where controls appear to have the most effect. These rose 0.3 per cent in May, the same as in March and a little below the 0.4 per cent of April.

When seasonal factors are discounted, wholesale prices of industrial commodities rose 0.4 per cent, the same as in April.

Lebanon Expects Blow From Israeli Retaliating For Airport Massacre

By THE ASSOCIATED PRESS
Israeli jets swooped over southern Lebanon and troop movements were reported along the border Thursday night, heightening expectation of an attack in reprisal for the massacre at Tel Aviv international airport.

In Israel, fear of another terrorist attack sent extra troops and ambulances racing to the airport Thursday night, and passengers and all baggage on at least six incoming flights were searched thoroughly. Unofficial reports said the lone survivor of the three-man Japanese suicide mission told interrogators that another slaughter

was planned. There was no attack. In a midnight radio broadcast, Transport Minister Shimon Peres said "increased security measures have been put in force" and will continue.

Israeli Skyhawk and Mirage jets spent 15 minutes over southern Lebanon.

Galifianakis In County As Campaign Nears End



By STUART SAVAGE
Reflector Staff Writer

Congressman Nick Galifianakis, seeking the Democratic nomination to the Senate in tomorrow's second primary visited Pitt County yesterday, stopping first at the Pitt-Greenville airport where he held a news conference, then moving on to Farmville for a reception and some more campaigning there.

In Greenville, Galifianakis charged that his opponent for the nomination—incumbent Sen. B. Everett Jordan—has been making some "extravagant... very wild charges," in what the Senate hopeful said "must be considered a frantic effort to catch up..." He also said the incumbent has been "copying what we have been doing," in the way of campaign advertising.

"It's just an effort on the part of Jordan to catch up," Galifianakis said.

"We are very gratified at the progress of our campaign and sure we are going to be victorious."

"There is not going to be enough time left," Galifianakis said, to refute Jordan's charges one by one. "Instead, I am going to rely on the good sense of the people of North Carolina to be very wary of last minute claims in a political campaign."

The Congressman said Jordan's posture "as the only man to do anything for the farmer" is "of course, absurd."

Galifianakis said Jordan was not moved to conduct hearings into the Common Market threat to North Carolina tobacco "until he was challenged for re-election this year, and was the same senator who introduced no tobacco legislation of any kind

(Continued On Page 12)



QUARTET OF SPEAKERS ... The four seniors delivering brief speeches at the 1972 Rose High graduation are (left to right) Robbie Cox, Delores Harris, David Howell, and Joe O. Swain, Jr. (Reflector Staff Photograph)

Rose High Grads Given Diplomas At Annual Stadium Ceremonies

By JERRY RAYNOR
Reflector Staff Writer

A few more than 400 young men and women made their final appearance as students at Rose High School Thursday night as they marched across the stage in the field at Ficklen Stadium to receive high school diplomas.

After two weeks of dreary weather, the seniors had a clear twilight sky overhead for this memorable occasion. For the first day of June, the air was unseasonably crisp, and the evening star came into view as the graduation ceremony proceeded.

Following the traditional practice of using student speakers instead of guest speakers, the class was this year represented by four speakers. Usually, the black student and the white student with highest academic standings represent

their graduating class as the two class speakers.

This year a dilemma was posed because three white students, all male, had maintained a straight A average throughout high school. The class solved the problem by opting to have all three—Robbie Cox, David Howell and Joe Swain, Jr. as speakers.

Delores Harris, highest ranking academically of Rose's black students, was the only female in the quartet of student speakers.

The four speakers coordinated their brief individual speeches to one unifying theme, "Preparing for Tomorrow."

The theme, Katherine Williams, who introduced the speakers, explained, comes from the Rose High seal, which the graduating class for 1972 had designed and adopted.

Speaking on the topic "Extra-curricular Activities," Robbie Cox, the first speaker noted the "almost endless list of extra curricular activities available to students."

"The most important effect these have," Robbie said, "is student involvement, the kind of involvement necessary to a meaningful life."

Delores Harris, whose topic in the theme was "Academics," focused on academic studies as "a means of self-discipline and studies in preparation for challenging professions."

The young lady said that academics also entailed "learning to disagree, and yet to maintain respect for others."

"When we respect the views, knowledge and culture of others," Delores observed, "we find a key to solving human relations."

David Howell, speaking on "The Non-Academics," began his speech by quoting the famous line about beauty from Keat's poem "Ode To A Grecian Urn." Making reference to composers, carpenters and sculptors as examples of creators of beauty, David said that we are faced today with the fact that "artistic styles change as rapidly as scientific theory."

"Academics gives the means of understanding," he continued, "and the arts the means to coordinate our understanding."

Joe Swain, the final of the four students to speak, had the task of summarizing the attitudes expressed by the first three. "Rose High has not educated us," he began, "that was not its purpose. It has attempted to prepare us for the next stage of learning."

"We have facts," Joe said, "but are doomed unless we learn to use them to understand people."

"If we desire to be true to our own personality, we must be true to our beliefs, to speak out when we see injustice, if we have an emotion, to express it. What

600,000 Votes?

RALEIGH (AP) — North Carolina Elections Director Alex Brock predicted today about 600,000 votes will be cast in the state's runoff primary Saturday compared to more than 800,000 in the first primary.

Brock said past experience indicates the voter turnout in the runoff will be smaller. He added he expects the battle between Republican gubernatorial candidates Jim Jesse Helms and Jim Holshouser will bring out more GOP votes than in the first primary but that the Democratic turnout will drop.

Polls will open at 6:30 a.m. and close at 7:30 p.m.

Holshouser Objects To Restrictions On Press

By TOM BAINES
Reflector Staff Writer

Republican gubernatorial hopeful Jim Holshouser says that restrictions on the press, as advocated by his GOP opponent, would be a disaster and an infringement on not only the federal but state constitution.

"There have been times when I've disagreed with the press," he said here Thursday. "The news media in North Carolina, no more than any place else, is perfect. And there is no question that there are times when we would like to fuss."

He added however that "I don't think we ought to forget that this is one of the basic freedoms on which this country was built and the first sign of any dictatorship, any where you look, across the history of this world is: one, gun control; and two, restrictions on the press."

Holshouser, making an airport stop here as part of a swing across the eastern part of the state, linked his name with U.S. Senate candidate Jesse Helms of Raleigh as part of an east-west GOP ticket in November.

"Politicians all across the country talk about geography as being the key to winning statewide tickets," the Boone attorney asserted. "Tennessee did it in 1970 when they got Sen. Bill Brock running from Chattanooga in the eastern part of Tennessee and Gov. Winfield Dunn running from Memphis over in the western part of the state."

Holshouser contended, "That's the same opportunity we have in North Carolina as Republicans in 1972. With Jesse Helms, who is going to be a tremendously strong senatorial candidate, running real well as a

candidate from the east and the ballots that I can get from the western part of the state I'm sure is going to take us to total victory in November."

The candidate acknowledged that Helms, who recorded a landslide victory over Republican opposition in the May primary, is maintaining a neutral position personally as far as an endorsement of either of the candidates for governor but he claimed that "we have gotten a tremendous number of his supporters with us. I think it's because that they know that's the best way to see that Jesse Helms gets to the United States Senate."

Holshouser reiterated his stand that the newly organized Board of Governors should be allowed to make the educational decisions in North Carolina, (Continued on page 8)

Couple Speaks Vows In Ceremony On Saturday

ROCKY MOUNT — On Saturday in a double ring ceremony, Miss Charlene Amy Parkerson became the bride of Richard Monroe Joyner Jr. at 3:00 p.m. in Thorpe Memorial Chapel of the First Presbyterian Church here.

Dr. James M. McChesney Jr. officiated at the ceremony. A program of nuptial music was presented by Joseph Lupton of Roanoke Rapids, organist. The bride is the daughter of Mr. and Mrs. Ralph C. Parkerson of Rocky Mount. Given in marriage by her father, she wore an ivory lace dress trimmed in ivory satin. Her veil was of ivory illusion attached to a ring of ivory satin. She carried a bouquet of blue and white bridal flowers centered with white sweetheart roses.

Parents of the bridegroom are Mr. and Mrs. Richard M. Joyner of Rocky Mount.

Mrs. Alton Whitfield Adams, sister of the bride, was matron of honor. She wore a blue dress similar to that of the bride and her headpiece was attached with a blue bow. She carried three long-stemmed white roses.

The father of the bridegroom was best man. Ushers were Philip Rice Joyner, brother of the bridegroom, Alton Whitfield Adams, brother-in-law of the bride, and Frank Nelson Barbee.

Following a wedding trip to Georgia, the couple will reside in Myrtle Beach, S. C., where the bridegroom is stationed with the U. S. Air Force.

The bride is a graduate of Rocky Mount Senior High School and attended Nash Technical Institute. The bridegroom is a graduate of the Rocky Mount Senior High School and attended Atlantic Christian College, Wilson.

On Saturday morning, the parents, grandparents, aunts and uncles of the bride entertained the Joyner-Parkerson wedding party, families and friends at the Morris House Restaurant.

Guests were greeted by Mr. and Mrs. B. L. Joyner of Fort Leonard Wood, Miss., and Mr. and Mrs. John Marvin Sasser Jr. of Fulton, Md., aunts and uncles of the bride.

Good-byes were said to Mrs. J. L. Parkerson of Greenville and Mr. and Mrs. Marvin Sasser of Rocky Mount, grandparents of the bride.

Following the rehearsal Friday evening, the bridal couple, members of the wedding party and friends were entertained at the home of Mr. and Mrs. Richard M. Joyner at a cake cutting.

Mr. and Mrs. Allan Harrell greeted guests and receiving were Mr. and Mrs. Moody H. Ward.

Assisting in serving were Mrs. Jack Thompson, aunt of the bridegroom, and Mrs. John M. Sasser Jr., aunt of the bride. Miss Sheree Joyner and Miss Patrice Sasser assisted in serving. Mrs. W. L. McMillan said good-byes.

Women Attend Wednesday Meet

WILLIAMSTON — The Home Economics Division of the Coastal Plains Development Association met here at the Town and Country Restaurant Wednesday.

After a report by James A. Walker III, Plant Manager for Jefferson Mills concerning the Jefferson Mills Child Development Center for children of their employees, a tour of the center was taken by the group.

The purpose of the Child Development Center is to help each child develop physically, emotionally and socially. Absenteeism and turnover of employees is four times less than a year ago when the center was originated, Walker pointed out.

Members of the CPDA Committee attending from Pitt County were: Mrs. Howard Burns Jr.; Mrs. H. W. Wheelers; Mrs. Chester Worthington; and Mrs. Gloria Boswell. Mrs. Sue May and Miss Addie Gore, extension agents, accompanied the group.



HEAVENLY TOAST — Only two ingredients are called for, gluten bread plus butter.

Heavenly Toast Is A Simple Snack

By CECILY BROWNSTONE
Associated Press Food Editor
Every time we serve Heavenly Toast tasters want the recipe. It's hard to believe that such a simple snack can be so popular. We've given the basic directions before, but this variation—Sesame Toast—is new.

Serve this toast (either version) absolute plain. To top it with a spread is unnecessary; as a matter of fact the spread will only obstruct its flavor.

We use lightly salted butter when we make this snack. But a friend of ours who is on a salt-free diet reminds us that the gluten bread called for is unsalted and so she makes Heavenly Toast with unsalted (sweet) butter. She says that this salt-free version is excellent.

Members of Wedding Party Are Announced

Miss Sharon Ann Allen and William Van Stocks Jr., who are to be married Sunday at 3:00 p.m. in the Trinity Free Will Baptist Church, Pike Road, have announced members of their wedding party.

The Rev. Billy Ray Jordan of Wilson will be the officiating minister.

The bride will be attended by her cousin, Miss Nell Harris, of Washington as maid of honor. Bridesmaids will be Mrs. Lynn Paul of Pike Road, Miss Rhonda Graham of Raleigh and Miss Linda De Hoog of Plymouth.

Groomsman will be Craig Allen, brother of the bride-elect, Mark Webb and Mike Hazelton of Greenville.

The bride will be given in marriage by her father, William M. Allen, and the bridegroom's father, William Van Stocks Sr., will serve as best man.

Music will be presented by Mrs. Phillip Newberry, pianist, and Miss Gilda Avery, soloist. Mrs. Frankie Waters will be mistress of ceremonies.

Homemaker's Haven By Sue May Pitt Home Agent

"From the strawberry patch" come succulent berries in abundance. Take advantage of these and use them as a real treat for any meal of the day. An uncooked jam is a quick way to take care of those extra berries that you just can't possibly consume immediately. Here's the recipe and procedure:

Strawberry Jam
2 cups finely mashed or sieved strawberries
4 cups sugar
1 package powdered pectin
1 cup water
Method of combining ingredients:
Powdered pectin: Combine fruit and sugar. Let stand about 20 minutes, stirring occasionally. Stir the pectin into the water, bring to boiling point and boil rapidly for 1 minute, stirring constantly. Remove from stove. Add the fruit and stir about 2 minutes. Pour into jelly glasses. Cover and let stand at room temperature 24 to 48 hours or until gelled. Seal with paraffin and store in a freezer. Jam made in this way will keep weeks at refrigerator temperature. This recipe makes about 6 glasses.
If you prefer using liquid pectin... omit the powdered pectin and water and use ½ bottle of liquid pectin (½ cup). No cooking necessary.

"From the women" throughout the county comes leadership in abundance.

Mrs. Alfred McLawhorn was recently recognized as outstanding leader of the year by Renston Nobles Extension Homemakers. In appreciation of her contribution, Mrs. McLawhorn was presented a silver cranberry tray and server. In making the presentation Mrs. Lyles Russell, club president, stated "Ada Gould is an outstanding homemaker, wife, mother, grandmother and citizen. She is active in her club, her church, the local P.T.A. and other civic organizations. Mrs. McLawhorn was selected because she is dedicated, faithful, loyal, dependable, thoughtful, kind, energetic, and enthusiastic."

Mrs. John Condon, a Griffon Extension Homemaker and co-chairman of the East Central District citizenship committee has just participated in a state-wide workshop. The planning group met at the Betsy-Jeff Penn 4-H Center for a two day session.

Mrs. Nina Phillips, second vice president of Pitt County Extension Homemakers represented the organization at a district leadership seminar held in Kinston.

Odd Size Is New Average

NEW YORK (AP) — More than half the women in the United States wear the wrong bra size according to research which has brought about the first new concept in the design of bras since their introduction in the 1930s.

From its beginning the bra-ware industry has always made bras in even numbers, 30, 32, 34 and so on. Why? Tradition, money involved in stock and

just plain unthinking. However, when the National Bureau of Standards announced early in 1971 that in the past 10 years the American woman's bust had increased one inch, making the average bust no longer 34-B but 35-B, one manufacturer of intimate apparel, began developing a bra for the odd sized bust of 33, 35, 37 and 39. Kayser-Perma-Lift tested it on approximately 300 of its women employees across the country and discovered that slightly more than 55 per cent wore odd sized bras.

Edna's Beauty Salon

Special -
Cold Wave reg. \$10 NOW \$7.50
Cold Wave reg. \$15 NOW \$10
Westwood Subdivision Greenville
756-3980

Belk Tyler

2 Days Only!
Friday—June 2
Saturday—June 3



PORTRAITS BY HAMILTON & HAMILTON

BABIES - CHILDREN - ADULTS
COLOR
8x10
PORTRAIT
\$1.00
NO HANDLING
CHARGE

Limit - 1 child per family at \$1.00. Additional subjects \$2.00
Each if taken separately, or Only 50 cents each Additional
Person if taken in a group.

Photographers' Hours:

• Friday: 10 A.M.-8 P.M. (Lunch 1-2) (Supper 5-6)
• Saturday: 10 A.M.-5 P.M. (Lunch 1-2)

IN DOWNTOWN
GREENVILLE

Brody's

DOWNTOWN
PITT PLAZA

Has Her
Favorite
Graduation
Gift
CHECK
YOUR LIST

★
Lingerie
★
Luggage
★
Jewelry

★
Electric
Hair
Dryers

★
Sportswear

★
Cosmetics

★
Mirror
Trays

★
Jewelry
Boxes

★
Shop Brody's

Downtown

9:30 A.M.

-6 P.M.

Or Shop Pitt

10 A.M.

-9 P.M.

For Your

Graduation

Gift Shopping

Convenience

★
GIFT
WRAPPING

FREE

Brody's
DOWNTOWN
PITT PLAZA

This Teacher Gets 'F' For Pursuit

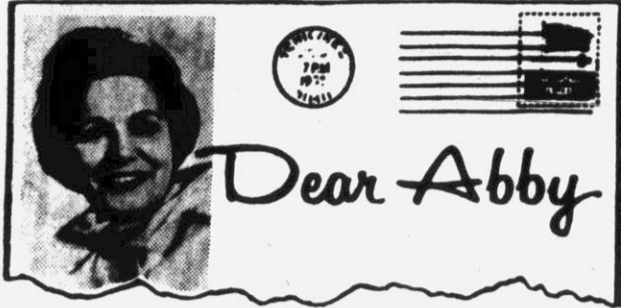

By Abigail Van Buren

(© 1972 by Chicago Tribune-N.Y. News Synd., Inc.)

DEAR ABBY: I've heard of students having crushes on their teachers, but what about the teacher who has a crush on a student?

There's this 14-year-old girl in one of my classes who is just beautiful. I can't keep my eyes off her even tho she is half my age.

Do other teachers have problems like this? What's to be done? My class is her favorite class. I don't believe in anonymous letters so I will sign my name, but please respect my need for anonymity. TEMPTED TEACHER

DEAR TEACHER: Teachers have crushes on students for the same reason students have crushes on teachers. Immaturity. [I refer to a 14-year-old panting after a 28-year-old, and vice versa.] What's to be done? Admire her from afar and keep your eyes, your thoughts [and everything else] off her. Small wonder your class is her "favorite." You've telegraphed your feelings to her, and she got the message.

DEAR ABBY: I live near a lovely elderly couple who buried their only daughter two years ago.

Before this daughter's death she started an afghan for her mother. She was about three-quarters finished when she passed away, poor soul. Well, I love to do needlework and had plenty of time, so I offered to finish the afghan. My neighbor said she would be grateful if only I would.

I finished it gladly, and when I presented it to my neighbor we both cried.

Abby, I was so happy to do that small favor for my neighbor, but she spoiled it all when she gave me a beautiful appreciation card with a \$20 bill in it. I was so hurt I just didn't know what to do. I didn't want any pay. I felt it was an honor to finish something her daughter had started for her.

I still want to return the \$20, but my husband says I will hurt her feelings something terrible. Please help me decide. HURT

DEAR HURT: Consider the woman's feelings. She expressed her appreciation in a manner that she thought fitting. Don't fault her. I think your husband is right.

DEAR ABBY: "HARD OF HEARING" asks, "So what do I do when I cup my ear and strain to hear until I am nearly exhausted, and people look at me as tho to say, 'I'll give this cheap dumb cluck who's deaf and won't wear a hearing aid a hard time and refuse to speak up?'"

Let me tell you about a friend of mine. He wears a dummy hearing aid, which looks exactly like a real one, but isn't. His explanation:

"I have a partial hearing loss, but I can hear all right if people will speak up. But for some strange reason they resent being told to speak up. I used to wear a real hearing aid, which as soon as it was discovered, caused everyone to talk so loudly to me they practically shattered my eardrum. So now I wear a dummy hearing aid, which causes people to speak up as soon as they see it."

MRS. H.: ROSWELL, N. MEX.

DEAR MRS. H.: Hear, hear!

DEAR ABBY: I was pleased with your handling of the Reverend Problem in Meadville, Pa.

I am a 76-year-old retired Lutheran pastor and I do not resent it when someone says, "Good morning, Reverend." Some people do not always remember my last name.

Doctors are called "Doctor," and Catholic priests are called "Father," and rabbis are called "Rabbi," so why is our friend in Meadville so sensitive?

JUST AN OLD REVEREND

DEAR ABBY: I'd like to nominate myself for sainthood. My wife left me for another man. Three weeks later he kicked her out and I took her back. She got herself \$3,000 in debt, gambling, and I paid it off. The only time she ever said "no" was when somebody asked her if she's had enough. We're still married. A GLUTTON FOR PUNISHMENT

CONFIDENTIAL TO R. R. IN PORTLAND, ORE.: If you are serious about locating E. R. to tell her you are sorry and want to make everything up to her, save enough money to hire a private investigator. After your behavior, I wouldn't blame her family for refusing to let you know where she and your children [which you denied were yours under oath in court] are now living. If you find E. R. and she tells you to get lost, leave her alone.

Problems? Trust Abby. For a personal reply, write to ABBY, BOX 69700, L. A., CALIF. 90069 and enclose a stamped, addressed envelope.

Add accident prevention to cooking chores in the kitchen. Keep flammables away from the heat (that includes long hair and kimono sleeves).

LOSE WEIGHT NOW

VICALTEIN can trim you down naturally. No special exercising, no starvation diets, no dangerous drugs. VICALTEIN, a pleasant tasting tablet, utilizes a balanced formula of Protein to curb your appetite as well as furnish Vitamins, Minerals and Carbohydrates to keep you feeling fit. Use common sense, a natural diet is best for you. VICALTEIN provides a natural protein diet at an average daily cost of only 31c. Developed and used by physicians for over 15 years. If you don't lose weight, you don't lose your money. We refund it.

Eckerd's Drugs

FARMVILLE FURNITURE COMPANY
GREAT GIFTS!
for grads!
FROM OUR GIFT SHOP
- BOYS - - GIRLS -
TAYLOR TIES CURLER BONNETS
TOILETRY CASES HANDBAGS
CUFF LINKS SACHETS & SOAPS
TENSOR LAMPS VANITY TRAYS
KEY CASES MAKE-UP MIRRORS
COME IN AND SEE OUR ENTIRE SELECTION TODAY
FARMVILLE FURNITURE CO
122-126 S. MAIN ST.
FARMVILLE, N.C. 753-3101

Don't take chances on fire, theft, moths, heat.
Why gamble with your precious fur? See us for:
• Modern Spacious Vaults Temperature and humidity are carefully controlled
• NU-GLO Revitalizing Hygienic cleaning and glazing, and lustre restored
• Fur Repairing Estimate and advice before any work is done
• Remodeling Superb re-styling by fur fashion experts
Blount-Harvey
SHOP DAILY FROM 10:00 A.M. TIL 5:30 P.M.

Meat Pie Comes From England

By CECILY BROWNSTONE
Associated Press Food Editor

British cuisine has always been noted for its good meat pies. And the following recipe, developed by an English home economist now working in this country, deserves its share of fame. When tried at our house, it was gobbled up. However, we managed to stow away a couple of portions and found they reheated beautifully.

Why do we call this dish a "plate pie?" Because plate pie is an English term for a two-crust pie in contrast to a deep-dish pie. Typically English, too, is the filling made with beef and mushrooms and seasoned with Worcestershire sauce.

ENGLISH PLATE PIE
2 tablespoons butter
1 medium onion (finely chopped), 1/2 cup
1 pound ground lean beef
1 cup (generous) chopped mushrooms, 1/4 pound
2 teaspoons Worcestershire sauce
1/2 teaspoon salt
1 beef bouillon cube
1/2 cup boiling water
1 tablespoon flour
2 tablespoons cold water
1 package (11 ounces) pie crust mix
1 egg
1 tablespoon milk

In a 10-inch skillet heat butter; add onion and cook gently until softened. Stir in ground beef; cook, mashing with a fork to crumble, until meat loses its red color. Stir in mushrooms, Worcestershire and salt; cook for 2 minutes.

Dissolve bouillon cube in boiling water; add to beef mixture. Stir flour with cold water to make a smooth paste; stir into beef mixture. Stirring constantly heat to boiling point; cook for 2 minutes. Remove from heat; set aside.

Prepare piecrust mix as label directs. Use half to line bottom of an 8-inch pie plate. Roll out remaining half to cover pie.

Fill pie shell with beef mixture; cover with remaining pastry. Flute edges and slit top for steam to escape.

Beat egg with milk to blend. Brush over top pastry.

Bake in a preheated 425-degree oven until crust is well browned—40 to 45 minutes. Let cool on wire rack for 10 minutes before serving.

Makes 6 servings.

Wedding Invitation

Mr. and Mrs. James Earl Pollard request the honor of your presence at the marriage of their daughter, Sherry Kay, to Stephen MacLamb Grant, on Sunday, June 4, at 3:00 p.m. at the Belvoir Free Will Baptist Church.

Worth The Wait To Buy Home

IPSWICH, England (WNS) — Heather Bilner, 17, went through with her wedding to Keith Mixer, 27, but called off their European honeymoon to line up for 17 days in order to buy a home. "There were eleven houses for sale and ten other couples already queued up," explained the bride. "Prices are rising so fast that this is our last chance." The Mixers have been taking turns standing on line and sleeping in their car. "Even our wedding presents and mail are being delivered in care of the line of eleven cars," added the new Mrs. Mixer.

Wall hooks or pegboard can be one solution to keeping some small appliances handy, without using counter space. Mountable "wallables" are hand mixers, electric knives, warming trays.

Belk Tyler

SALE

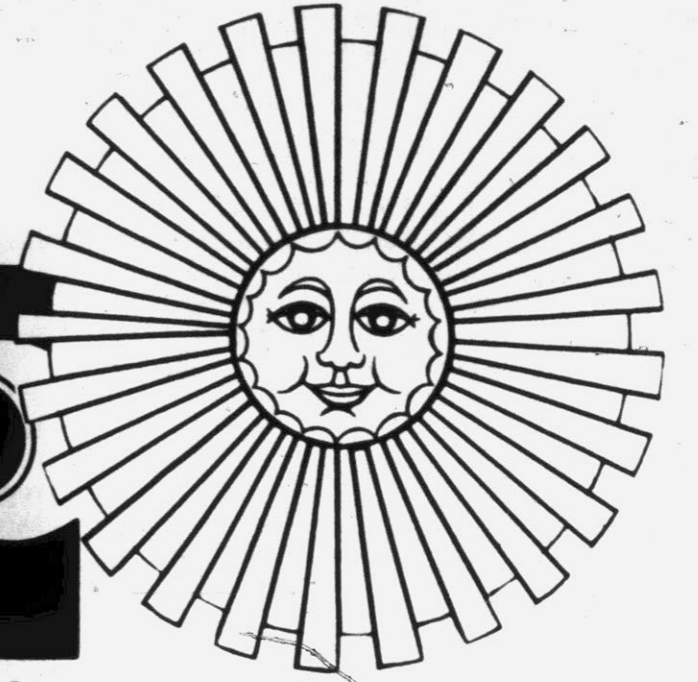

SUMMERTIME

... And Salute To Eastern North Carolina Days!
HURRY, TOMORROW IS THE LAST DAY!!!

All good things must come to an end and so must this sale! Tomorrow is the last day to get in on the savings for the entire family and all your vacation needs!!!

Men's Walk Shorts
4.88 6.88

usually \$6 usually \$8

Easy-care. Textures, plaids, stripes, solids. 30 to 42.



Sale!
Men's Knit Shirts
Famous Name

Reduced 1/3 Values from \$7 to \$10

Assorted stripes and solids in fashion collar, crew necks, zip fronts.



Sale!

Men's Double Knit

Sport Coats

Regular 60.00 **44.88**

Easy-care 100 percent polyester tailored with wide lapels, hi center vents, squared pocket flaps. Solid colors, great-looking fancy effects.

Father's Day June 18th!!!

Ice Cream Freezers



6.88

Regular 8.99

5 quart. Hand operated. Polyethylene tub. Gold color.

Woven Place Mats
4 for

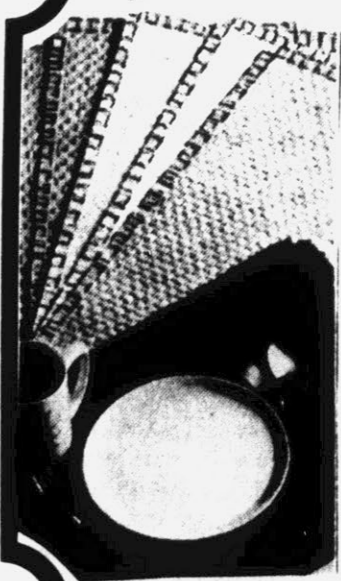

1.88

Bright deep colors. Hand washable. Variety of colors.

Room-Size Colonial Oval Rugs

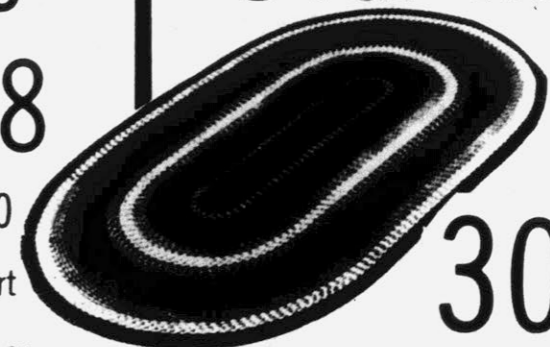

Reg. 39.99

30.88

Great Americana colors: rust, gold, avocado. Reversible for twice the wear.

Use your Belk Credit Card...
It's Convenient!!!



'Heiress' Panty Hose

usually 1.39 **97¢**

Assorted summer shades. Non-run. Includes queen size.

Double Knit

Dress Slacks

10.88 & 12.88

Regular 14.00 Regular 16.00

100 per cent textured polyester in smart solid and neat fancies. Belt loop flares or beltless. Continentals. 30-44" waist.

Sweat Shirt



Prints

SPECIAL VALUE

1.88

85 percent cotton and 15 per cent rayon. Asst. colors.

Ladies' Rayon



Briefs

3 for

1.00

Rayon acetate tricot tailored brief with elastic leg. White only. Size 5 to 10

'Heiress'

Anti-Static



Lace Slip

Usually 4.00

2.88

Gripesest nylon slip with lace applique. White only. Average 32-38, and short.

Crew Neck



Knit Shirts

Usually 3.50

2.44

"Hand Off" embroidered emblem. Polyester and cotton. All the jean colors. Size 8-20.

IN DOWNTOWN GREENVILLE. OPEN MONDAY THRU FRIDAY TIL 9, SATURDAY TIL 6.

Phone 758-5588



Here's an inside "lion" on where you can get someone to babysit, do odd jobs, household chores, or business related, short term jobs.

PART TIME EMPLOYMENT

Good Citizens Will Be Voting

Every registered voter in Pitt County has a responsibility to return to the polls Saturday to participate in the selection of party nominees for important state offices.

The relatively light vote in Pitt County in the first primary four weeks ago and the predicted even lighter vote anticipated for this coming Saturday should be a matter of genuine concern to every citizen.

The decisions made this Saturday by those who go to the polls will have an important bearing on the future of every citizen of this state for the next four or more years. Those decisions should be made by

the largest possible number of citizens...not by just a relatively few.

In the first primary in Pitt County approximately 50 per cent of the registered voters in each of the major parties went to the polls. There were some 13,800 Democratic votes out of some 27,000 registered Democrats and some 1,500 Republican votes from some 3,800 registered Republicans.

The same thing was true throughout most of North Carolina. About half the registered voters went to the polls.

For the second primary an even lighter vote is expected. Some observers predict a total vote of 55 to 60 per cent of the number in the first primary. If that is the case, only 25 to 30 per cent of the registered voters in the state will participate in the second primary, and under those circumstances 13 to 15 per cent of the registered voters of the state will be able to name the party nominees.

Every citizen is extremely conscious of his right to vote and quick to move to protect that right if he feels it is threatened. But when it comes to exercising that right, there is a distressing amount of apathy on the part of many citizens. They are willing to leave it up to others to make the decisions at the polls.

We urge every registered voter in Pitt to make a special effort to exercise his right to vote Saturday. The decisions to be made at the polls here in this county are decisions which should include the votes of the more than 30,000 eligible voters in this county.

The best government, under our democratic process, begins with individual voter participation that reflects individual citizenship responsibility. Do your part as a good citizen of Pitt County and North Carolina Saturday by going to the polls and exercising your right to vote.

Ferment Raises New Questions

By BRYAN HAISLIP
RALEIGH, N.C. — Where student rights and school discipline collide, which must give way for order to prevail?

The question couldn't have been asked in the days of the little red schoolhouse where the hickory stick, like the blackboard, was standard equipment in every classroom.

Today, social ferment and youth unrest make it a puzzle



BRYAN HAISLIP

for administrators and citizens alike. More than an academic matter, it has baffling legal ramifications.

School officials stand at the crossing point of duty to maintain orderly operation, and due regard for the lawful rights of students. On one hand is the threat of disruption of the educational process; on the other, the hazard of being hauled into court.

"The evolution of student rights and the judicial protection of these rights will be regarded by many at best as a mixed blessing and at worst as a serious interference with internal school discipline and affairs," said Robert E. Phay and Anthony B. Lamb, experts in school law.

Schools must and do have plenary authority to regulate conduct calculated to cause disorder and interfere with educational functions, they added. "The primary concern of the courts is that students be treated fairly and accorded minimum standards of due process of law."

No Court Consistency

The courts have spoken, but without consistency. Although recent years have accumulated a body of judicial decisions on the subject, no clear guidelines have been drawn.

For example, more than 50 cases during the last year and a half have dealt with hair length of male students as a ground for expulsion or suspension from public schools.

The decisions fell into three groups: (1) wearing long hair to school is constitutionally protected; (2) it is not protected; and (3) the constitutional question is not ruled on. In some cases, the same court rendered decisions which seemed to fall on both sides of the issue.

Recent litigation in the area of student rights is reviewed by Phay and Lamb

in the current issue of "Popular Government," the publication of the Institute of Government at Chapel Hill. Phay is an Institute faculty member who fields school law, and Lamb is a law school graduate and research assistant.

Conduct Code Recommended
They offered these recommendations for North Carolina schools:

1. Adopt a grievance procedure for students and faculty.

2. Adopt written regulations on student conduct. These regulations should specify the potential penalty for a violation. They should be worked out in consultation with principals, who should have a checklist of things to do before they take action. When completed, the regulations should be made public and widely distributed.

3. Adopt written procedures for handling discipline cases.

4. Develop an emergency plan to deal with school disorders.

A code of conduct for students in schools throughout the state, uniform where possible, has been proposed by the citizens committee named by Gov. Bob Scott to probe causes of school unrest.

At the present time the committee said, many schools do not have written regulations covering student conduct and causes for suspension or expulsion.

1969 Decision Cited
Courts usually have turned to a 1969 Supreme Court decision for a legal yardstick on challenges to the constitutionality of school regulations. That decision in a Des Moines, Iowa, case threw out a regulation banning the wearing of armbands to protest the Vietnam War.

The tests laid down, said Phay and Lamb, are: is the student's activity protected by the Constitution, is the fear or apprehension of a particular disruption sufficient to outweigh the right involved, and has the school board met its burden of proof on the issue?

The application of the tests has produced varying results, leaving school officials to proceed on their own in balancing student rights against the possibility of disruptions.

Court cases dealing with student rights have covered a wide range, from staging demonstrations and wearing buttons or armbands to distribution of literature, dress codes and hair length, and the attendance of pregnant students.

Statecraft At Summit Level

By ROWLAND EVANS and ROBERT NOVAK
MOSCOW — Three nights running last week, Henry Kissinger, President Nixon's national security adviser, sat until 3 a.m. with Soviet SALT negotiators and refused to be panicked into concessions on the last two sticking points.

Then, at 11 a.m. on Friday, Soviet foreign minister Andrei Gromyko informed him the Soviet government had finally accepted compromise formulas on these two questions: whether missiles on the obsolescent Soviet G-class submarine would count against the 950 submarine-launched missiles authorized by the freeze; and a complex, delicate question dealing with SS-9 silos, which house the giant Soviet intercontinental missiles.

At the end of the Wednesday night session in the Kremlin, the exhausted Kissinger woke up the equally fatigued President Nixon with a phone call a few minutes before the break-up at 3 a.m. Thursday, to report no progress. The President's response: hold fast; don't cave in.

What this incident reveals is not that the Nixon-Kissinger team can claim bargaining triumphs over the Russians. Which side got the most out of the dramatic agreement on strategic arms limitation (SALT), if either one did, will not be known for a long time. What the incident does illustrate is the fundamental principle that has guided the President during three years of the most wide-ranging and now successful negotiations ever conducted with the Russians.

The principle: the U.S. wants agreement with the Soviet Union on many issues, starting with SALT, but not a single one of the issues is so important that it can be purchased at cut rates by the Russians.

In short, the President sought by a variety of tactics to inform the Kremlin that, however unfavorable the impact on his reelection prospect, failure was always an acceptable possibility.

Kissinger himself made that fact inescapably clear when, at the invitation of Communist party chief Leonid Brezhnev, he made his secret visit to Moscow in mid-April. Contrary to reports that Kissinger went to Moscow to warn Brezhnev in advance about mining the harbors of North Vietnam, his real purpose was to try to break the SALT deadlock.

Kissinger's implicit message to Brezhnev was this: the President can come to the summit conference and comfortably leave it without signing a SALT agreement. Moreover, Kissinger rejected an appeal that the U.S. use its influence to encourage the Christian Democratic part of West Germany to support the Moscow-Bonn treaty. That would have been American money in the summit bank, but it went beyond Mr. Nixon's formula of businesslike negotiating based on facts, not gimmicks.

Likewise, the President's decision to mine Haiphong harbor was the clearest possible signal to Moscow that he was willing to sacrifice the long-planned summit meeting itself to prevent disaster in Vietnam. That message was not lost on the Kremlin.

There are other, lesser examples of the President's studied, restrained approach toward negotiating with the Russians, an approach calculated not only to obtain equity but also to transform a generation of Soviet love-hate for the U.S. into something very different — a healthy, genuine respect.

Certainly Mr. Nixon's extraordinary success here confirmed his judgment that the Soviet leaders respect

(continued on page 5)

TRAGEDY IN THREE ACTS!



By ART BUCHWALD

We Run Out Of Bombs?

WASHINGTON — It was hard to believe, but in October, 1972, the United States ran out of bombs.

Secretary of Defense Melvin Laird broke the bad news to President Nixon. "I'm sorry, Mr. President, but we have no bombs left to drop on Vietnam. We're completely out."

"But that's impossible," the President said. "I was assured we had enough bombs stockpiled for five years."

"Under ordinary conditions we would have, but we've been dropping them at such an accelerated rate that we

ran out last Friday. There isn't one bomb left in the United States or any of its overseas bases."

"Can't we borrow some bombs from our allies?"

"We've already borrowed every bomb we could from Britain, France, Belgium, West Germany, Spain and Greece. We owe them 2.42 billion bombs, and they say they aren't going to lend us any more until we pay the interest on the ones we have already. At least 6 per cent that comes to an awful lot of bombs."

"But Melvin, we've got to have bombs or our strategy of

bringing Hanoi to her knees will fail. Surely a great industrial giant like the United States can rise to the challenge."

"We've tried, sir, but production just can't keep up with demand. Every time a



ART BUCHWALD

bomb comes off the assembly line, it's immediately attached to a bomb rack and dropped on Vietnam. To make matters worse, the Air Force, Navy and Marines are fighting over every bomb that is made. They had a dog fight over the Lockheed plant in San Diego the other morning and the Navy shot down an Air Force B-52 because it claimed the Air Force had stolen their bomb."

"This is serious, Melvin. If we slow down the tempo of the bombing, the North Vietnamese will interpret it as a sign of weakness. Have you checked any of the underdeveloped countries? Surely they must have some we can buy."

"We've looked into it, Mr. President, but the underdeveloped countries are refusing to sell their bombs. They've decided bombs are more valuable than gold, and because of the shortage they are now using them as currency. The latest rate of exchange is 100 trucks for one bomb."

"How did we get into such a position?" the President asked in an exasperated voice.

"I guess it was our fault, Mr. President. When we said we would bomb only military targets in Vietnam we had a sufficient supply of bombs. But when you gave the order to bomb anything they wanted to, the Air Force and Navy went ape."

"Also, the South Vietnamese army didn't help much. Every time they saw a water buffalo in a rice paddy, they called for an air strike."

(Continued on page 5)

Today's Social Center

By HAL BOYLE
NEW YORK (AP) — The U.S. business office used to be a place of work only. Today it has become pretty much the social center of American life.



HAL BOYLE

As many a boss is aware, getting a job done is only a dim problem in the back of many a worker's head when he gets up in the morning and comes to his home away from home—the office.

In some ways he finds his office more relaxing than his home, because he has fewer responsibilities there and isn't annoyed by such intruding inconveniences as a frowsy wife and noisy dullard children.

Millions of American working husbands and wives symbolically run away from home every day now. They go to the office.

Why? Because that's where the real fun is. That's where life can be lived to the hilt.

A business office is still reckoned as a market place. But that is only one of the functions it served. It is also a rest home, a restaurant, a hospital, a recreation area, an entertainment complex, a beauty parlor, a barbershop, a church, a gymnasium, a forum, and a passion pit where there is more hanky panky going on than at the average drive-in theater.

You go into the conference room, and what is going on there? The group may be considering raising or lowering the price of a product. It is more likely, on the other hand, to be arguing over whether management should be asked to change the color and design of the drapes.

You go up to any desk at random. (Continued on page 5)

40 Years Ago Today

By GWYN COGHILL
June 2, 1932

With the statewide Democratic Primary only one day away, candidates were today making last minute appeals to the people while election officials prepared to take care of what is expected to be the heaviest vote in the history of the county. F. C. Harding, chairman of the Pitt County Board of Elections, urged the people to vote as early as possible especially in Greenville where the largest casting of votes is expected to take place. The polls will open at sunrise 4:48 and close at sundown 7:26. The purpose of this primary is to name delegates to the county convention to be held at the Pitt County court house on June 11 and to select township committees.

An ocean breeze, bullet free, ripped the Confederate flag at Fort Fisher, North Carolina today for the first time since it fell in 1865 under northern gunfire. While the flag fluttered, a monument was dedicated to the fort's dead defenders.

(Continued on page 5)

Other Editors Say The Deficit Climbs

(Rocky Mount Telegram)
Despite all efforts, the nation's 1972 trade deficit climbed over the \$2 billion mark last month, as the value of imports exceeded exports by the second highest amount on record.

In only four months the nation managed to exceed last year's trade deficit of 12 billion.

For January through April the deficit was \$2.2 billion. For April alone, the Commerce Department pointed out that the value of imports exceeded exports by \$699 million, a figure topped only by last October's \$821 million.

In 12 of the last 13 months the nation has turned in a deficit in its merchandise trade balance, and last year's deficit was the first since 1888. Obviously, something is wrong with our trade setup.

A trade deficit puts additional pressure on the strength of the dollar overseas, since it means that more U.S. money is going out of the country and it reflects on the competitiveness of American industry with other countries.

But as far as consumers themselves are concerned, a trade deficit is not necessarily bad, since it means a wider choice of goods for them to choose from, what with the increased amounts of imported goods now available in this country.

But that's the short-range view. The long-range effects are not all that beneficial. These imports are competing with domestic products, and that's not so good for American producers.

In April, exports actually declined from the March level by 3.4 per cent, largely because not as many jumbo sets were shipped out as in March.

The drop in exports, however, was combined with only a small 9.3 per cent decline in imports.

A Commerce Department official claims the main reason for the continued deficit is that the American economy is expanding fast, making it a good market for imports while the economies of other countries are still sluggish, making them relatively poor markets for American goods.

That is a convenient answer, but of course it isn't the only reason. The horrendous costs of American labor has tended to price some U.S. goods out of the world market, while cheaper foreign labor makes overseas products more attractive to American consumers looking for bargains in our inflated economy.

Strength For Today

ALL TO A GOOD END
Everything that happens to us may be used to our benefit if we will only prove diligent and faithful.

Many years ago a rich recluse lost his money. This seeming catastrophe changed his whole nature for the worse but for the better. He came out of long hiding and for the first time entered into life and enjoyed it. One of the most radiant Christians I have ever known has spent her life in a wheelchair. The happy-faced little girl who passes my home frequently cannot take a step without difficulty and pain.

Sickness often has a way of making people better. Occasionally it makes them worse, destroys their morale and leaves them in lifelong

bitterness. But usually it has the opposite effect on their characters. One reason is that it gives them time to do a lot of thinking, which they could not do amid the rush of daily activities. As someone put it in a letter I received recently, "We call it illness, but God calls it stillness." If we won't stop and rest and be thoughtful, God passes sentence upon us and sends us to bed for a while to think things over and commune with our souls. We call it illness, but He calls it stillness—a time when He can speak with some possibility of being heard.

Hard as it is to believe, it nevertheless remains true that nothing ever happens to us which is not for our good if we make it so.

By Earl Douglas

Some Boards Mere Appendages

By JOHN CUNIFF
AP Business Analyst

NEW YORK (AP)—The board of directors, as constituted in many companies "is an anomaly bordering on an absurdity... it is an appendage rather than governing head... it reigns rather than rules."

The statements are derived from an analysis by Dr. Eugene Jennings of Michigan State University that accompanies a survey of what is described as the 46 top companies in the Fortune magazine list of 500 largest industrials.

Jennings doesn't claim that these successful companies have permitted their boards to become mere appendages, but he claims that many corporations, including famous ones, are guilty of that lapse. They are, he says,

immature.

Successful directors today are anxious to determine their proper function and purpose, especially after the sudden troubles that have endangered giants such as Penn-Central. But that anxiety, Jennings suggest, is recent.

Not long ago, he says, "the directors were selected to grace the corporate image." Their names and sometimes their presence lent prestige to a company. Their services otherwise were almost irrelevant."

There was—and still is in many companies—the attitude that the board should be an exclusive club of successful chaps who maintained a discreet and easy conviviality that originated years earlier in an Ivy League school.

The survey, by Earle Brown & Associates for the executive search firm of Lamalie Associates, also shows: They are directors of five other organizations, 59 years old, in their 11th year as a director, are paid between \$2,000 and \$10,000 a year.

Despite their somewhat passive role in the past, Jennings believed that the role of directors is growing in importance as American business matures.

The first stage of maturity was manufacturing, the second managerial. The third and final stage of maturity, he states, is corporate government, in which the focus of responsibility broadens enormously.

Jennings, a management professor and consultant to bluechip companies, claims

that the whole corporation—employees, managers, directors—must be made more responsive to the reality of the world today—a reality that includes not only profits but consumerism, women's rights, environmental pollution and so on.

These are issues that will require the director to speak up. The president may be challenged by a board that recognizes the need to be responsive, to be mature.

During this period of transformation there will be great stress in the board room, Jennings states. "The president will know by the noise... when he is entering State Three maturity." And he adds: "For many a chief executive it is later than he cares to think!"

The Daily Reflector

INCORPORATED
209 Cotanche Street, Greenville, N.C. 27834
Established 1882
Published Monday Through Friday Afternoon and Sunday Morning

DAVID JULIAN WHICHARD, Chairman of the Board
JOHN S. WHICHARD—DAVID J. WHICHARD
Publishers
Second Class Postage Paid at Greenville, N.C.

ABC

SUBSCRIPTION RATES
Payable in Advance
Home Delivery By Carrier \$2.25
Motor Route Monthly \$2.25
By Mail:
One Year \$27.00
Six Months 13.50
Three Months 6.75
(Prices include Tax By Mail except in Pitt Co. Add 1 percent)

MEMBER OF ASSOCIATED PRESS
The Associated Press is exclusively entitled to use for publication all news dispatches credited to it or not otherwise credited to this paper and also the local news published herein. All rights of publications of special dispatches here are also reserved.

UNITED PRESS INTERNATIONAL
Advertising rates and deadlines available upon request Member Audit Bureau of Circulation.

Asserts Tax Cut Plan Is 'Sound'

KINSTON, N.C. (AP) — North Carolina Advisory Budget Commission Chairman Tom White says Lt. Gov. Pat Taylor's tax cut proposal "is sound and will provide a measure of relief for a lot of people in North Carolina who need such relief the most."

Taylor, who faces Skipper Bowles in the runoff for the Democratic gubernatorial nomination Saturday, has proposed elimination of state income taxes on persons earning \$100 or less a week.

White, a former state senator, told a news conference in Kinston Thursday that he believes Taylor's proposal "can be done within the framework of our present tax structure and without the addition of new taxes."

White noted statements ear-

lier this week by Sen. Herman Moore, D-Mecklenburg, chairman of the state Tax Study Commission, saying that there are "grave constitutional questions" which would make it difficult for Taylor to implement his proposal without raising taxes for middle income persons.

"I have examined the sections of the constitution referred to and find that these sections do not apply to the income tax. They only apply to property taxes..." White said.

"It is my opinion that the proposal made by Lt. Gov. Taylor can be enacted into law without violating the provisions of our Constitution."

White said he believes "the state can well afford to forego the small amount of revenue involved in order to help a large number of North Carolinians who are trapped with low incomes in this day of rising costs and crippling inflation."

Gives Blood For Himself

CHARLOTTE, N. C. (AP) — A arthritic sufferer who will undergo a hip operation is donating blood — for himself.

His blood has an antibody so rare it cannot be matched.

The man, Gerald Grasty, 27, of Statesville, donated a pint of blood at the Charlotte Red Cross blood center Wednesday. In all, he will donate three pints so that doctors will have it on hand during the operation in case it is needed.

He is crippled by the arthritis and walks painfully with the aid of crutches.

He underwent an operation on his right hip last March. Arthritis had worn out the socket of his hip joint and it was replaced by a plastic cup.

After a sufficient quantity of his blood has been donated, frozen and stored, a similar operation will be performed on his left hip — making it easier for him to walk.

When operated on in March he was given someone else's blood. Doctors say this blood may have helped build up the antibodies that now make matching impossible.

Buchwald . . .

(Continued from page 4)

One sniper in a tree cost us 200,000 tons of bombs. We dropped more bombs on Highway One last week than we dropped in all of World War II."

"I'm going to issue an executive order declaring that every dairy in the United States must start manufacturing bombs."

"Every dairy?" the secretary of defense said.

"That's correct. It's obvious my butter-and-bomb policy isn't working. So until we have enough bombs to halt Communist aggression, no one in this country gets any butter."

"That's a drastic measure in an election year, Mr. President."

"It has to be done, Melvin. I'm not going to be the first President of the United States to go down in history as the one who ran out of bombs."

Police Hunting Gorilla Statue

CANTON, Ohio (AP) — Canton police are looking for a gorilla — of the statue variety.

Police said Arlie Cornell, owner of the Adventure Putt Golf Course, reported Thursday that the display attraction he kept at the course was missing.

The missing gorilla is described as 7½-feet high, covered by black nylon, with yellow eyes, outstretched arms and a red tongue.

CLARK'S

DISCOUNT DEPARTMENT STORES
A DIVISION OF COOK UNITED, INC.

SPECIAL JUNE SAVINGS FOR BRIDES and GRADS

PRICES EFFECTIVE FRIDAY, JUNE 2nd & SATURDAY, JUNE 3rd, 1972

#C4305



#C4506



GENERAL ELECTRIC AM/FM CLOCK RADIO

- Value leader with Solid-state design.
- Snooze-Alarm™ Clock.
- 4" dynamic speaker.
- Lighted clock dial.

OUR REG. TO 25.93

19.97 YOUR CHOICE

GENERAL ELECTRIC AM DIGITAL

- Wake-to-music OR Music Alarm.
- Sleep switch shuts off radio automatically.
- Adjustable up to 3 hours.

#C1400



GENERAL ELECTRIC AM CLOCK RADIO

- Large, easy-to-read clock face.
- 3½" dynamic speaker.
- Automatic volume control.
- Easy-to-clean polystyrene cabinet.

8.99 OUR REG. 10.97

#FXH-47



#FXC-39



SHARP AM/FM TABLE RADIO

- Features sleep switch, automatic radio alarm, illuminated clock.
- AFC switch.
- Earphone.

OUR REG. TO 39.96

29.96 YOUR CHOICE

AM/FM TABLE RADIO

- Push button AM/FM and AFC switches.
- Twin 7½" dynamic speakers.
- Walnut grain wood cabinet.

#V636



GENERAL ELECTRIC PORTABLE PHONO

- 4-speed changer holds 6 records.
- Shuts off automatically or repeats last record.
- 45-rpm adapter included.
- Positive selection indicator for 12-, 10-, and 7" records.

23.86 OUR REG. 27.86

#8415



GENERAL ELECTRIC PORTABLE CASSETTE

- Slide-a-matic T-bar function control.
- Remote control microphone allows off/on operation from mike.
- Two-way power.
- Automatic shut-off.

34.78 OUR REG. 38.78

#335



MAYFAIR PORTABLE 8 TRACK TAPE PLAYER

- Includes speakers, amp, full controls, earphone jacks.
- Operates anywhere on C-batteries or converts (optional) to AC power.

29.94 OUR REG. 36.94

#LM2



true-to-light II by Clairol

- 4-way light selection, day-office-evening or home.
- Thumb wheel swivels mirror.
- Dial control light changes.

13.97 OUR REG. 17.97

#P4810



GENERAL ELECTRIC AM/FM PORTABLE

- Two-way power.
- Built-in automatic frequency control (AFC) on FM.
- Slide rule dial.
- 3" dynamic speaker.

15.97 OUR REG. 18.83

#325

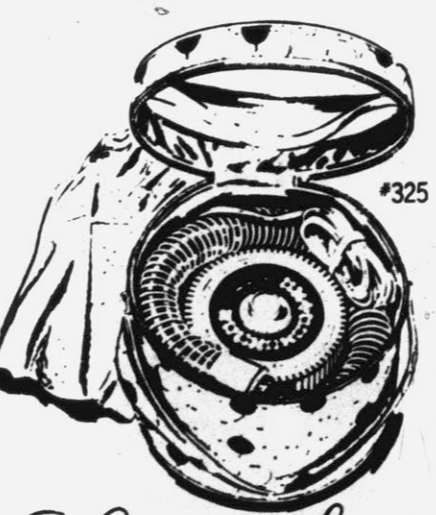

Lady Schick TOTE 'N DRY HAIR DRYER

- Colorful hatbox tote.
- New floating bonnet.
- Four temperature settings.
- Quick and easy to operate.

10.97 OUR REG. 13.97

#HD63

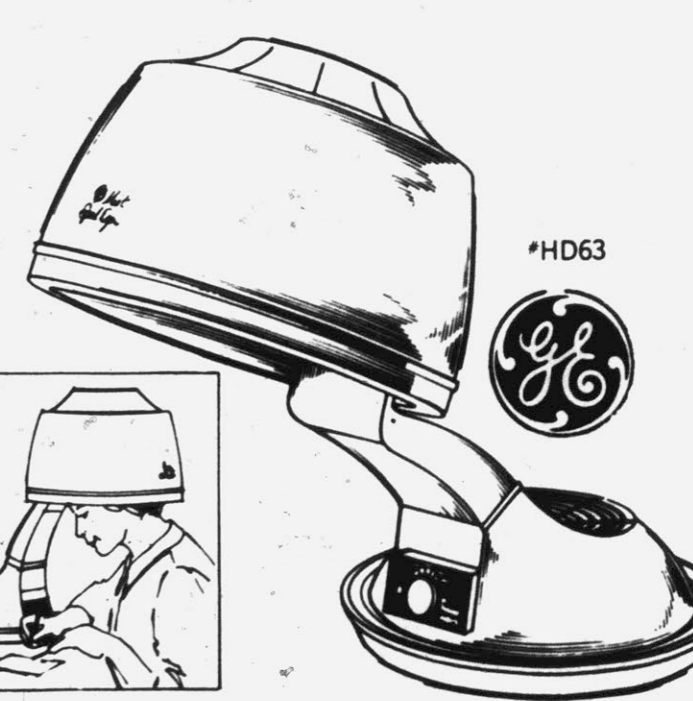

GENERAL ELECTRIC MIST SPEED HAIR DRYER

- All new design.
- Tilt and touch hood.
- 4 position heat control.
- 1000 watts for fast drying.
- Jumbo hood.

26.97 OUR REG. 31.97

#G115



FOLK GUITAR

- Standard size, steel string.
- Slotted head.
- Steel reinforced neck, screwed bridge, mahogany shaped sides.

14.96 OUR REG. 19.96

Shoemasters

421 Evans Street
In The Heart Of Greenville

SHOP TONIGHT UNTIL 9

Your Headquarters for **Hush Puppies**

Now you can **CHARGE IT** At absolutely no increase in price



WEST END SHOPPING CENTER

OPEN MONDAY THRU SATURDAY, 9:30 A.M. TO 9:30 P.M.

If we sell out of any advertised specials, you will receive a written order, "Raincheck" which entitles you to buy the item at these advertised prices when our stock is replenished. (excluding clearance items)

WE RESERVE THE RIGHT TO LIMIT QUANTITIES



Left to Right:

- | | | | | | |
|---|--|--|--|---|---|
| <p>First row from bottom:
Rita Bullock
Debra Brown
Patricia Ann Brown
Nancy Barnes
Edna Barnes
Deborah Andrews
Evelyn Andrews
Nancy Brown
Brenda Best
Brenda Alston</p> | <p>Second row from bottom:
Larry Carroll
Ervin Coddell
Joseph Atkinson
Billy Clemons
Dennis Clemons
Clarence Brown
Barbara Barfield
Patricia Lee Brown</p> | <p>Third row from bottom:
Diane Clemons
Jean Council
Brenda Clemons
Valerie Battle
Janet Cartwright
Nancy Braxton
Faye Albritton
John Crandol
Charles Cooper</p> | <p>Fourth row from bottom:
Glen Carr
Shirley Council
Alice Daniels
Elsie Bandy
Donna Coward
Sally Bartie
Joyce Bailey
Vicky Clark
Mary Bland</p> | <p>Fifth row from bottom:
John Blow
Bobby Clark
Bryan Bloom
Ernest Briley
Michael Burroughs
William Bartie, Jr.
Charlie Chancey
Glenn Brown</p> | <p>Sixth row from bottom:
Lennie Tillery
Roy Andrews
Vernon Brown
Robert Battle
Bonnie Bunting
James Mitchell Pierce
Johnny Corbett</p> |
|---|--|--|--|---|---|



Left to Right:

- | | | | | |
|--|--|--|--|---|
| <p>First row on bottom:
Susan Davenport
Shirley House
Deborah Hardee
Susan Johnston
Evelyn Harrell
Linda Hyman
Brenda Jones
Edna Howard
Alice Howard</p> | <p>Second row from bottom:
Susan James
Alice Hardy
Myrtle Jenkins
Peggy Hyman
Teresa Manning Harrell
Addie Ebron
Elsie Doughtie
Lois Daniels
Marsha Drake
Gwendolyn Hudson</p> | <p>Third row from bottom:
Cynthia James
Eula Hollis
Bobby Daniels
Almitchell Ebron
Melvin Jennings
Charles Jenkins
William Hardison
Heber Haddock
Bobby Hines
Jack Hartley</p> | <p>Fourth row from bottom:
James Heath
Harvey Horne
Harman Jenkins, Jr.
Jimmy Hayes
Ernest Roberson
Teddy Hyman
James Hollis
Carlton Floyd
Dennis Thigpen
Chauncey Gilliam</p> | <p>Fifth row from bottom:
Clifton Cogdell
Henry Dixon
Ray Harrell
Calvin Dixon
Benjamin Doughtie, Jr.
Walter Harris
Daniel Highsmith
Louis Jenkins, Jr.
Richard Davis</p> |
|--|--|--|--|---|

Many Graduates From North Pitt High School

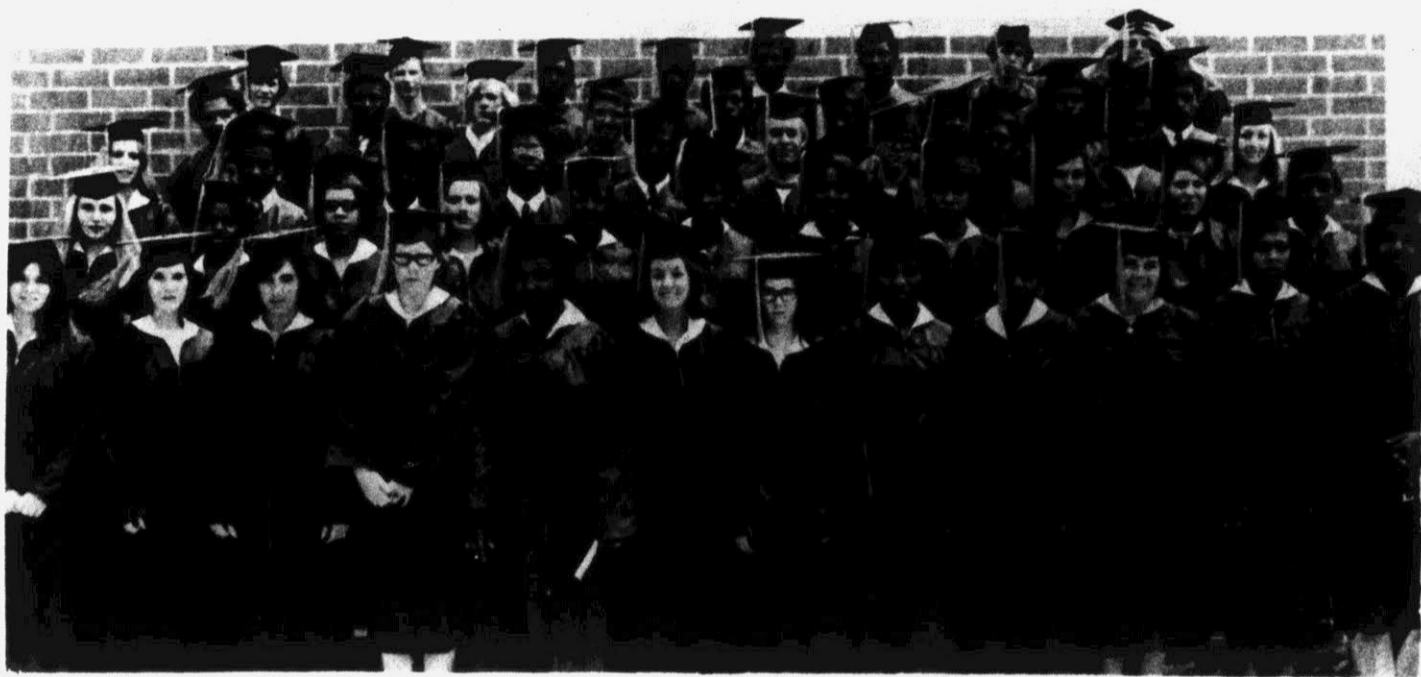

Left to Right:

- | | | | | |
|---|--|--|---|---|
| <p>First row on bottom:
Barbara Manning
Deborah Lassiter
Brenda Haddock
Brenda Griffin
Peggie Ann Ross
Debra Manning
Joyce James
Betty Moore
Dimple Little
Anita Langley
Mary Little
Linda Massenbarg</p> | <p>Second row from bottom:
Annette Pilgreen
Janis Langley
Shirley Murchison
Dorothy Farmer
Jacqueline Wilson Moore
Bernardine Jordan
Rosslyn Jones
Janice Knight
Constance Pearce
Mavis Louise Padgett
Eriena Nelson</p> | <p>Third row from bottom:
Gail Michaels
Jerry Mullins
James Jones
Curtis Everett
William Moore
Richard Nelson
Victor Gray
Phillip Perkins
William Little
Myrtle Ormond</p> | <p>Fourth row from bottom:
John Moore, Jr.
Charles Tetterton, Jr.
Francis Manning, Jr.
Bruce Mayo
Lester Mooring
Leonard Perkins
James Little
Oscar Little
William Lee, Jr.</p> | <p>Fifth row from bottom:
Charles Mayo, Jr.
Edward Manning
Clifton Manning
Michael Fleming
Johnny Little
Clinton Paige
David Perry
Michael Martin</p> |
|---|--|--|---|---|



Left to Right:

- | | | | | |
|--|---|--|---|--|
| <p>First row on bottom:
Yvonne Stancill
Debra Stancill
Marilyn Sumner
Linda Rose Smith
Mary Sneed
Phyllis Sheppard
Barbara Ward
Dolores Smith
Edith Williams</p> | <p>Second row from bottom:
Hattie Stalon
Marlene Waters
Linda Smith
Yvonne Pippens
Betty Roberson
Barbara Willoughby
Mary Redmond
Sharon Williams
Joseph Curtis Willoughby
Brenda Faye Purvis
Gloria Teel</p> | <p>Third row from bottom:
Bidy Worsley
Hilda Whitley
Christine Spear
Joyce Winston
Verta Sneed
Jessie Taylor
Mildred Wilkins
Brenda Joyce Purvis
John Simpkins
Robert Sheppard</p> | <p>Fifth row from bottom:
Otis Whisenant
Wallace Ruffin
Dennis Purvis
Willie Sharpe
Alonza Price
Thomas Sneed
George Worsley
Charles Weatherington
Clifton Stokes</p> | <p>Fourth row from bottom:
Robert Sutton
Charlie Wilson
Allen Spain
Elmon Woodson
Joseph Earl Willoughby
Ray Sharpe
Benjamin Worsley, Jr.
Bernard Williams</p> |
|--|---|--|---|--|

Pitt Students On Dean's List

RALEIGH — Nineteen students from Pitt County attained recognition for outstanding scholarship at North Carolina State University during the spring semester.

To win dean's list recognition, NCSU students must attain academic averages of 3.0 or better out of a possible 4.0.

Following are the Pitt students, their studies, parents and addresses:

GREENVILLE — Robert H. Daniel, Jr., biological sciences, Mr. and Mrs. R. H. Daniel 227 Orton Dr.; Frederick W. Derrick, math, Mr. and Mrs. J. O. Derrick, 215 Kendall Ct.; Robert O. Fleming, Jr., engineering operations, Mr. and Mrs. R. O. Fleming, 1707 S. Elm St.; Robert H. Forbes, engineering, Mr. and Mrs. R.H. Forbes, Rt. 1; Carl R. Gilchrist, zoology, Mr. and Mrs. C. Gilchrist, 1104 E. Wright Rd.;

Linda S. Sewall, civil engineering, Mr. and Mrs. S. A. Sewall, 110 Lakewood Dr.; Ralph C. Tucker, individualized study program, Mr. and Mrs. R. C. Tucker, Rt. 9;

FARMVILLE — Franklin L. Bradham, politics, Mr. H. H. Bradham, 106 N. Pitt St.; Robert A. Eason, math, Mr. and Mrs. M. L. Eason, Jr.; Carol Willis Modlin, engineering, Mrs. and Mrs. C. W. Modlin, Sr., 505 W. Church St.; Harvey L. Winstead, Jr., civil engineering, Jr. and Mrs. H. L. Winstead, 109 N. Davis Dr.;

AYDEN — George A. Corbett, aerospace engineering, Mr. R. Corbett, 500 Colonial St.; Robert L. Short, chemical engineering, Mr. and Mrs. L. E. Short, 202 Juanita Ave.;

WINTERVILLE — Leon D. McLawhorn, pre-veterinary medicine, Mr. and Mrs. C. L. McLawhorn, Rt. 1; Stephen J. McLawhorn, agriculture, Mr. and Mrs. C. L. McLawhorn, Rt. 1;

BETHEL — William K. Abeyounis, aerospace engineering, Mr. and Mrs. K. Abeyounis; Mrs. Teresa M. Kirkpatrick, science education, Mr. and Mrs. W. M. Manning; **STOKES** — Jeffrey D.

Rawls, mechanical engineering, Mr. and Mrs. J. W. Rawls, Rt. 1; Linda N. Rawls, medical technology, Mr. and Mrs. J. W. Rawls, Rt. 1.

Kenneth Dunn and Daniel Lefler, rising sophomores at East Carolina University, have been awarded full scholarships by the Air Force ROTC.

The scholarships will be in effect this fall and will continue for three years. Dunn and Lefler were awarded the scholarships on the basis of their grade point averages during the freshman year and their outstanding performance in the ECU AFROTC Detachment 600.

Upon graduation, they will receive commissions as second lieutenants in the Air Force. Both will be assigned to a pilot training base.

Dunn is the son of Chester L. Dunn of Fountain, Route 1. Lefler is the son of D P Lefler of 1801 Shannonhouse Drive, Charlotte.

Math Program At ECU Completed By High Schoolers

Twenty-one area high school students have completed a mathematics instruction program at East Carolina University.

They are as follows: Ayden-Grifton School — Michael I. Phillips, C. L. Westbrook,

Michael R. Worthington, and Lloyd Butler; Bear Grass School — Carolyn Gray Hodges, Russell D. Roberson Jr., Vann R. Rogerson, and Steve A. Taylor; D. H. Conley School — Mark H. Smith; J. H. Rose School — William L. Barlow, Julia Ann Cleveland, Elizabeth Jean Hagan, David N. Howell, and the William C. Penny; Kinston Schools — James P. Barfield and William A. Hobbs; Tarboro

School — Michael G. Kelsh, Robert N. Pitt, and Hal A. Thorne; and Washington Schools — James A. Duckett and Margaret McGrath.

This program has been offered for three consecutive years by the ECU Mathematics Department without charge to qualified high school students. This year the program was partially funded by the National Science Foundation and the students received free instructional material and some compensation for travel expense.

A similar program will be offered during the next academic year. Dr. Tullio J. Pignani, chairman of the mathematics department, is director and instructors are Mrs. Nannie Lee W. Manning,

Dr. Robert J. Hursey Jr., and Dr. F. Milam Johnson. Students interested in participating should contact either their high school counselor or the math department for application forms. The applications are due by June 15.

Anniversary Of Chorus Sunday

The Community Gospel Chorus of Greenville will observe its 19th anniversary Sunday at 5 p.m. at Cornerstone Missionary Baptist Church, corner of 13th and Railroad Streets.

Mrs. S.A. Walker is president of the chorus.

Church To Mark 'Women's Day'

Women's Day will be observed Sunday at 3 p.m. at Wells Chapel Church.

Missionary Odessa Jordan of Edenton will be the guest speaker. Her topic will be "Beautiful Women." Music will be presented by the Crusaders Gospel Choir, under the direction of Johnny Wooten.

BIG CHOICE
NEW YORK (UPI)—Do you have a brand preference when you buy ice cream? Says the editor of American Dairy Review: "There could be up to 10,000 ice cream brands being sold in the United States."

Choral Group At Warren Chapel

The Choral Group of the Central Orphanage, Oxford, will be at Warren Chapel Church Sunday at 3 p.m.

The church is located on the Farmville Highway, near Ballards Cross Roads.

H.V. Bryant, superintendent of the orphanage, will deliver the address.

The program is being held to benefit the orphanage.

We SPECIALIZE in ORCHID CLEANING

Each garment is hand cleaned and cleaned separately, if needed.

We Pick Up & Deliver

Scott's Cleaners Incorporated

One Day Service On Drycleaning & Laundry

111 West 10th St. Phone 752-2131

Listen to Zales newest stereo ideas!



Stereo component system by Lloyd with AM-FM radio and phono. Tunes AM and stereo-FM stations, has a 4-speed stereo phonograph, sliding controls, two speakers, earphone jack and wood-grain cabinet.

Your Choice **\$129.95**

Sharp AM-FM stereo component system with 8-track tape player. Has a built-in 8-track tape player, AM and FM-stereo tuner, twin speaker cabinets, push-button controls, and walnut grain finish.

Four convenient credit plans available • Zales Revolving Charge • Zales Custom Charge • Master Charge • BankAmericard

ZALES

Pitt Plaza (Open Mon. - Sat., 10 A.M. to 9 P.M.) Phone 756-0141

CAPRI. The sexy European at a shamefully low price!



Sold more cars the first year here than any other import in history.

Inside, Capri offers as standard, vinyl buckets, four-speed shift, and a no-nonsense dash with rocker switches. In a word, sexy!

Outside, the same story. Sexy! Right down to its styled steel wheels and radial tires. Plus rack-and-pinion steering and power front disc brakes. Just what you'd expect in an expensive European sports car.

Only Capri's not expensive! Maybe

that's one reason why it sold more cars in its first year here than any import in history.

And now Capri comes on in an even more passionate version — the Capri 2600 with a fervent 2.6 litre V-6 under its bonnet. Come in and see our "hot" entry in the import sales race.

Capri. Imported for Lincoln-Mercury. The sexy successful European at a shamefully low price.

SEE YOUR MERCURY MAN SMITH WALDROP MOTORS, INC.

2201 Dickinson Avenue Greenville, North Carolina

BETTER IDEAS MAKE BETTER CARS



Lincoln-Mercury. Nobody in the business has more kinds of cars for more kinds of people.

High Point Taking Police Scandal 'Rather Calmly'

HIGH POINT, N.C. (AP) — High Point appears to be taking the scandal in its police department rather calmly. Twelve of the department's 150 uniformed members have either resigned or been fired in

the past week. Six have had charges of burglary filed against them. The other six presumably had knowledge of the criminal activity and said nothing. High Point police, led by

Chief Laurie Pritchett, have handled the investigation. Pritchett announced the first resignations and dismissals last Friday.

At this week's City Council meeting, Mayor William Ben-

cini said "Personally, I endorse all of the police leaders to the fullest extent." The council then voted unanimously not to ask for an outside investigation of the police corruption.

A suggestion to that effect had come the day before in an editorial in the High Point Enterprise. That editorial has been the only overt and public suggestion that High Point is not confident that the police department can police itself.

A local black leader, who asked not to be identified, said "As far as I can tell, the guys they've fired have been men first and police second. I'm confident that the chief is capable of cleaning things up. There are some people who don't think so, but I'd guess they are in the minority."

Another High Point resident said, "I was at a meeting last night and nobody mentioned it. This is a town where people are for law and order and have American flags on their car. Pritchett is quite popular."

Pritchett came to High Point in 1966 from Albany, Ga. While there, he developed a reputation as tough but fair for his handling of civil rights demonstrations led by Dr. Martin Luther King Jr.

As soon as he came to High Point, there was a heavy turnover in the force. High Point patrolmen began saluting their superiors. They stood straight on their street patrols, and kept their collars buttoned and their ties pulled tight. They did not

smoke while on public duty. Pritchett says, "If I knew why those men went bad, I'd bottle the secret and sell it. Our pay scale is not what I'd like it to be, but it's as good as any city our size in the state." Pritchett says he thinks the corruption was confined to the department's third platoon. Much of the blame thus far has fallen on David Jarret, a patrolman at whose home much of the \$5,000 in stolen articles recovered thus far was found. Jarret was "rookie coach" to many of the dismissed patrolmen, responsible for breaking

them in when they finished academy training. "Many of them were under his supervision, but they were men after all, and they knew what they were doing. They just mislaid their trust," Pritchett said. Jarret and the other 11 all were members of the third platoon.

The merchandise recovered thus far was found in the homes of Jarret and Patrolmen Archie Pilkenton and James Kelly. It has been traced to five different burglaries.

Those three, along with George Burton Jr., V. R. LeGrande, and James Howard, face criminal charges in state District Court on July 5. The charges also involve a robbery from a Putt-Putt golf course and rifling of coin-operated vending machines to which the officers held pass keys.

Two officers were dismissed but offered the opportunity to resign. They did not, leaving themselves an opportunity to appeal. They are Lt. Leonard

Boyd and Patrolman Ralph Farlow. Farlow was the department's officer of the year in 1971. Police say he wanted to join the force so badly that he went on a rice diet in 1969 and lost 40 pounds in one month to pass the physical requirements. Four others took the offer to resign. They are Sgt. Larry

Miller, and Patrolmen J. H. Gill, Lerue Morris and C. L. Hendrix.

Angel Food Cakes Diener's Bakery 815 Dickinson Ave.

Bowles Claims Runoff Win; Quick Tour Today

By RAY ROLLINS For The Associated Press RALEIGH (AP) — Hargrove (Skipper) Bowles, with a last-minute prediction that he "will win, and win going away," set out by plane from Raleigh to-

day for quick stops in Charlotte and Winston-Salem and a return flight to Raleigh for the wind-up of his runoff campaign for governor.

Bowles, front-runner in the May 6 primary, is seeking to

maintain his earlier lead over his opponent, Lt. Gov. Pat Taylor, and pick up some of the votes that went to candidates Wilbur Hobby and Dr. Reginald Hawkins in the first primary.

The Bowles theme, both in news conferences and in thank-you visits that have crisscrossed the state, has been to "keep on the high road—no mudslinging."

And Bowles, for the most part, has hammered away at the same issues he talked about before the first primary—career education, no new taxes, welfare reform, "roads where need dictates," a crackdown on drunk drivers and the pledge of "an open administration."

He added a proposal to limit campaign spending, saying that a candidate should neither have to be a part of a political machine, old or new, nor be excluded from running from office by a lack of funds.

Though Bowles stuck largely to a pledge not to get into a verbal hassle with Taylor, he often referred to him as "the new model Taylor." And he, finally, answered a Taylor charge — a new charge in the second primary — about which candidate is more closely identified with the current administration.

Bowles left his late Friday afternoon schedule open, to be free to go in any direction in the waning hours of the campaign.

He was then to fly home to Greensboro for the night, to vote early Saturday morning and then visit unspecified precincts somewhere in the state before returning to Raleigh when the counting begins.

"I'm feeling good about our chances," Bowles said at one point Thursday. "But you never know but what that one more hand you shake today will make the difference."

Gardner Home For Big Finale

ROCKY MOUNT (AP) — Republican gubernatorial hopeful Jim Gardner returned to his hometown Thursday night to wrap up his campaign in the east for Saturday's runoff election by promising eastern North Carolina a stronger voice in state government.

Gardner, a Rocky Mount businessman, planned to spend the day on the telephone attempting to round up last minute support. He will close out his campaign tonight with a rally in Asheboro.

At a shopping center rally Thursday night, Gardner told a crowd of several hundred persons that the "Democratic machine" has controlled North Carolina for 72 years.

"Those of us who live in this part of the state know the machine has left eastern North Carolina out of everything good," he said.

If elected, he said, "We're going to have a state where the people are listened to."

Gardner won support Thursday from an astrologer in Wilmington for his prediction that he will win the runoff with Jim Holshouser.

Betty Taylor, president of the North Carolina Astrological Association, volunteered to work up a chart on Gardner based on his birthday and the house of his birth. She refused to tell newsmen exactly what the chart indicated, but said the future looked "very strong" for Gardner through Saturday.

Gardner told audiences in Wilmington, Clinton, Salem, Goldsboro and Rocky Mount that he would win the nomination. Unlike the first primary, he refused to predict the margin.

Gardner had predicted he would win the first primary by

65 to 70 per cent. Instead he led Holshouser by less than 1,800 votes and gathered 49 per cent of the total vote.

In Fayetteville, he told campaign workers all he really wanted was "a victory by one vote."

Signboard Aims At Grandfather

HELENA, Mont. (AP) — An elephant with its trunk tied in a knot, so it can't inhale pollution, is pictured on a downtown billboard.

It's not this capital city that has polluted air—it's grandfather's pipe.

The full-sized signboard was put up on behalf of Aidan Myhre as a present to her grandfather, Associate Justice John C. Harrison of the Montana Supreme Court.

When Harrison smokes his pipe around the child, she tells him, "Don't pollute."

The poster repeats that admonition and adds, "Be a good president of the National Tuberculosis Association." He was elected head of the association a week ago in Kansas City.

The judge's son-in-law is an officer in a Great Falls, Mont., advertising company.

Singing Program Saturday Night

The Grindle Creek Church of God will sponsor a singing Saturday night at 7:30.

Guest singers include the Gospel Singing Echoes of Rocky Mount.

The Rev. W. L. Franks is pastor of the Grindle Creek Church.

FAMOUS POTTED
ROSE BUSHES
GROWING IN PLANTABLE POTS
SALE - GOOD thru June 10th

Buy 2
Save 25%

Buy 3 to 4

Buy 5 or more
Save 50%

CLOSED SUNDAYS

Sunshine Garden Center
Evans St. Ext. 1 1/2 Mi. So. of T.V. Station
Hours: Monday-Saturday 8 A.M. - 6 P.M.
Tel. 756-2629

W. C. "BILLY" CREEL
for
COMMISSIONER OF LABOR

30 YEARS EXPERIENCE
IN DEPARTMENT OF LABOR

Your vote and support will be appreciated

Saturday, June 3

- Industrial Safety Inspector, N. C.
- Department of Labor, 1942, 1943.
- Safety Director, N. C. Department of Labor, 1946-1971.
- Safety Coordinator, N. C. Department of Labor, 1971, in charge of developing State-Federal program for administering the federal Occupational Safety and Health Act of 1970.
- Past Chairman, Mid-State Safety Council.
- Past President, N. C. Society of Safety Engineers.
- Past Chairman, N. C. Chapter, American Society of Safety Engineers.
- Member, Executive Committee, Fertilizer and Textile Sections, National Safety Council.
- Chairman, Supervisory Training Committee, Fertilizer Section, National Safety Council.
- Speaker at numerous State and regional safety meetings.
- Speaker at seven annual sessions of the National Safety Congress.
- Certified Safety Professional.
- Active duty, U. S. Navy, 1943-1946.
- Discharged with rank of Lieutenant.
- Member Democratic Precinct Committee, 1946-1958.
- Chairman, Precinct Committee, 1959-1966.
- Member, State Democratic Executive Committee, 1966-1970.

PROFESSIONAL EXPERIENCE

PROFESSIONAL ACTIVITIES

MILITARY SERVICE

PARTY SERVICE

Merchants Stuck With Souvenirs

SAN DIEGO, Calif. (AP) — The Republicans moved their national convention to Miami Beach, Fla., and left many San Diego merchants with nothing but elephants—white elephants. Gift shop operator Mrs. Michael Mooney is offering rhinestone pins with the initials GOP at cost to anyone in the telephone book with those initials.

George Snell, sales manager of a downtown food store, is trying to find a market for such souvenirs as 600 dozen ashtrays and 600 dozen glasses inscribed with "San Diego—Republican Convention City."

He says some of the items are being purchased by Democrats. "They want them as gag gifts for their Republican friends," he says.

COMPLETE PEST CONTROL

WEY COWARD CO. INC. Complete PEST CONTROL

1710 W. 5th STREET GREENVILLE, N.C. PHONE 752-5175

Extra Low Discount Prices
On Our Prescription Drugs
Jack L. Tyler
Pharmacist, Owner

Shop and Save the Big Value way, Low Discount prices everyday. Have your doctor call your next prescription or transfer your regular prescriptions to Big Value Discount Drugs. We appreciate the opportunity to serve you. You will agree when we say our prices are all Low and Discount too. Compare!

BIG VALUE DISCOUNT DRUG STORE
2800 E. 10th St.
East 10th St.
Shopping Center
Phone 758-2181

OPEN
9 A.M. - 9 P.M.

"Dependable Discount Prescription Service"

Don't Be Confused By Campaign Distortions: Senator Sam Ervin Supports Senator B. Everett Jordan.

May 18, 1972

Statement of Senator Sam J. Ervin, Jr.

I favor the renomination of Senator Jordan as the Democratic Candidate for the United States Senate in the forthcoming primary.

As chairman of the Senate Committee on Rules and as a United States Senator from North Carolina during the past fourteen years, Senator Jordan has rendered services of great value to North Carolina and the nation. As a member of the Senate Committee on Agriculture and Forestry, he has supported much legislation of highest value to those engaged in the production of tobacco, soybeans, cotton, and other agricultural products; and, as a member of the Senate Committee on Public Works, he has been most diligent in promoting the development of rivers, harbors, and conservation projects in North Carolina.

While he has rendered great service to the state and nation in the past, I believe that his experience and the respect in which he is held in the Senate will enable him to render even greater services to the state and nation in the immediate future.

Reprinted From The
Greensboro Daily News,
May 17, 1972:

The four men involved generally conducted their first primary campaigns with fairness and civility. (One exception to that generality was Mr. Galifianakis' claiming in the closing days of the campaign that he had the endorsement of Sen. Sam Ervin Jr. when Sen. Ervin was in reality supporting Sen. Jordan.)

Vote Jordan
For U.S. Senator
Democratic Runoff
Saturday, June 3

Committee To Re-elect
Senator Jordan
Cliff Everett, Jr., Chairman

Stock And Market Reports

RALEIGH (AP) (NCDA) — North Carolina egg markets steady. Supplies fully adequate. Demand fair. Weighted average prices for small lot sales of consumer grade eggs in cartons delivered nearby outlets: Grade A large whites: 35.13. Medium whites: 29.18. Small whites: 23.37.

RALEIGH (AP) (NCDA) — The North Carolina hog market is steady to 50 cents higher today, with an instance 1.00 higher. Tops of 25.72-26.25 Rocky Mount; 25.00-26.00 Siler City, Denton; 24.75-25.75 Tarboro; 24.75-25.25 Bethel; 24.00-25.00 Kinston, New Bern, Benson, Lumberton; 25.50 Salisbury.

RALEIGH (AP) (NCDA) — North Carolina hens: Prices steady on heavy types today. Supplies plentiful, demand light. No light type sales reported. Heavies, at farm, 12 cents; f.o.b. plants 14½. North Carolina f.o.b. dock broilers: Market steady today. Supplies remained fully adequate for a generally good demand, weights desirable to heavy. F.O.B. dock weighted average price for less than truck lots sales of sized plant grade A broilers to be picked up at docks next week is 27.34 cents per pound.

NEW YORK (AP) — Blue chip stock prices slid back and forth in moderate trading today. The 11:30 a.m. Dow Jones average of 30 industrial stocks gained .75 to 861.47. Advances held a moderate lead over declines on the New York Stock Exchange. Big Board prices included Curtiss-Wright, up 1½ at 41¼; NLT, up 1½ at 45¼; Telex, up 1½ at 11½; Gillette, up 2 at 47¾; and Mobil Oil, off 1½ at 54.

Following are selected 11 a.m. stock market quotations:

Burroughs	186¼
United Utilities	17½
Heublein	60¾
Jeff-Pilot	49½
Wicks	44¾
Wachovia Realty	31¾
Eckerd	40½
Central Soya	28¾
Tri South	29¾
OVER THE COUNTERS	
Combined Insurance	27¾-27½
Franklinlife	21¼-21½
Hardee's	30-30½
NCNB	61-61¾
Piedmont Air	13¾-14¼
Integon	12¾-13
Little Mint	11-11½
Conner Homes	5½-5¾
Guardian Care	11-11¼
First Provident	6¾-7¼

by THE ASSOCIATED PRESS

Prev. Close	Day
29¾	30
13¾	13¾
8¾	8¾
42½	42½
47	47¾
60¾	61¾
30¾	31¼
22¾	22¾
28¾	29¼
34¾	35
29¾	29¾
26¾	26¾
59	59½
57½	57¾
31¾	31¾
132¼	131¾
9	9½
92	92½
22½	22¾
171½	171¼
30¾	30¾
124¾	125¾
23¾	24¾
66¾	66¾
25¾	25¾
75½	76
29¾	30
43	42¾
33½	33½
25¾	25¾
30¾	29¾
24¾	24¾
399	399¾
38¾	38¾
58¾	58½
19¾	—
68¾	68½
11¾	11¾

Loews Th	57%	57%
Monsanto	55%	55%
Nabisco	59	59¼
Natl Distillers	17	17¾
Norfo & West	75¼	75¼
Penney JC	80¼	79¾
Pepsi Cola	86½	87
Phillips Petr	29	29¼
Radio Corp	36%	35¾
Rep SI	23%	23¾
Reynolds Ind	73%	74¼
Seaboard Coast	62%	62¾
Sears Roebuck	116¼	117½
Sou Walry	97½	97¾
Sperry Corp	40	40
Std Oil Calif	59¼	58½
Std Oil NJ	75	73¾
Stevens JP	17½	17¾
Texaco Inc	32%	32¾
Tex G S	17¾	17¾
Textron Inc	33¾	34
Un Carbide	50¾	50¾
Uniroyal	17½	17¾
US Stl	30¾	30¾
Va El & Pwr	17¾	18
Wachovia	36½	37
Westing El	52¾	51¾
Weyerhsr	49¾	49¾
Winn Dixie	58½	58¾
Woolworth	36%	36%

Holshouser . . .

(Continued From Page 1) indicating that the East Carolina University Medical School issue should be resolved by the board and not the governor. He said that he was "going to leave that one up to the voters to talk about" when asked to comment on state GOP chairman Frank Rouse's decision to take a leave of absence from his position to campaign for Jim Gardner. "I don't think it would be appropriate for me, as a candidate to get into that little fracas."

Holshouser claimed that the possibilities of further division within the GOP party as a result of the move by Rouse depends on the attitude of the winner of the primary. "I can assure you that once this primary is over with, I know how to pull this party together. It's going to take a lot of Republicans working hard if we are going to win in November," he said, "I've known through primaries of my own in the past how that's done and I can assure you we will be united." Asked if he thought the winning candidate Saturday could count on the losing candidate's support, Holshouser replied, "I don't think there is any question about that. Jim Gardner has repeatedly pledged that he will be supporting me after the primary and I'm willing to take him at his word."

SINGING PROGRAM
The Ladies Auxiliary of the Meadowbrook Pentecostal Holiness will sponsor a singing program Sunday beginning at 2:30 p.m.
The Gospel Echoes of Windsor will be special guests.
The famous Mormon Tabernacle choir has 300 singers.

Obituaries

Smith
Mrs. Mary E. Smith, formerly of Ayden, died Wednesday in Brooklyn, N. Y. She is the daughter of Mrs. Lendora Stoton Phillips of 712 S. Pitt St., Ayden. Funeral arrangements are incomplete.

Harper
AYDEN — Mr. Roy Harper of 126 W. Ninth Street in Norfolk, Va. formerly of Ayden, died Monday after an extended illness at the Norfolk General Hospital. Funeral services will be conducted Saturday at 2 p.m. at the Norcott and Company Downtown Chapel by Elder J. L. Wilson. Burial will be in the Carmon Cemetery.

Mr. Harper, son of the late Mr. Eb and Mrs. Luvenia "Hitt" Harper, was born and reared in the Roundtree community of Pitt County, but had made his home in Norfolk for the past years.

Surviving him are two daughters, Mrs. Luvenia H. Wilson of Baltimore Md. and Miss Geraldine Harper of Rt. 1, Winterville; a sister, Mrs. Willie Idell Boone of Baltimore, Md.; three brothers, Alf Harper of Ayden and Tubie and Willie "Good" Harper, both of Baltimore, Md. The body will be at Norcott and Company Downtown Chapel from 6 p.m. Friday until the funeral hour. The family visitation at the chapel will be from 8 to 9 p.m. Friday. The family will be at the home of Miss Geraldine Harper near Roundtree.

Padley
AYDEN — Edgar E. Padley, 61, died suddenly at his home Thursday afternoon.

Mr. Padley had been in a declining health for several months. A lifelong resident of the Ayden community, he was a member of the Ayden Christian Church and was a retired civil service employee.

Funeral services will be conducted Saturday at 11 a.m. at Farmer Funeral Home here by the Rev. C. H. Overman. Burial will be in the Ayden Cemetery.

Surviving him are his wife, Mrs. Gladys Carson Padley; two daughters, Miss Betty Jean Padley and Mrs. Hadley Hunt, both of Lynchburg, Va.; his mother, Mrs. Betty Vann Padley of Ayden; a brother, J. L. Padley of Ayden; two sisters, Mrs. Margie Humbles of Ayden and Mrs. Howard Heath of Raleigh; and three grandchildren.

Morris
ANCHORAGE, Alaska — Funeral services for Mr. Rawlin Morris, a Pitt County native, who died Sunday, May 28, here, will be held Sunday at 2 p.m. at Cedar Grove Baptist Church, Rt. 2, Greenville. The Rev. Leroy Adams will officiate and burial

will follow in the Brown Hill Cemetery. Mr. Morris was a veteran of the Korean War and a graduate of the Chicago Electronics Institute in 1956. Survivors include his parents, Robert and Teasie E. Morris of Greenville; two sisters, Miss Sanjo Faye Morris of Greenville and Mrs. Theresa M. Smith of Washington, D.C.; one brother, Howard F. Morris of Anchorage, Alaska. Family visitation will be at Phillips Brothers Mortuary Saturday from 8 p.m. to 9 p.m.

Platt
Mr. Joseph Paul Platt, 69, of Wantagh, L.I., N.Y., died in Pitt Memorial Hospital Thursday morning at 2:45 following two days of critical illness. Funeral services and burial will be held Monday in New York.

Mr. Platt was born and reared in Long Island City, N.Y., and attended school there. He was employed by Consolidated Edison Company in Queen's County, N.Y., retiring in 1962, and was a member of Saint Barnabas Catholic Church in Bellmore, N.Y. Mr. Platt was visiting in Greenville to attend the graduation of his grandson from Rose High School.

Surviving are his wife, Mrs. Elizabeth Lederer Platt; a son, Joseph (Pete) Platt Jr. of Greenlawn, N.Y.; a daughter, Mrs. James R. O'Connell of Greenville; eight grandchildren; and a brother, William Platt of Howard Beach, N.Y.

Miss Fulghum Club Organized

New President
Miss Carolyn Fulghum of Greenville has been installed as president of the Eastern Tuberculosis and Respiratory Disease Association.

Miss Fulghum succeeds R. K. Bob Montague as president.

Board members representing Pitt County are John H. Bizzell, Garland Beddard, Mrs. Lib Eagles, J. W. Grimes, Dr. Joe Pou, and Dr. Allen Taylor, all of Greenville, Sam Bundy of Farmville, and Dr. Dan Jordan of Bethel.

Other officers from this area include J. J. Edmondson of Maury, vice president; J. T. Snowden Jr. of Greenville, treasurer; and Curtis Hendrix of Greenville, assistant treasurer.

Looking For Church School Will 412 Grads Be Started Monday

WILLIAMSTON — Notes from "The Newsletter," the information sheet published by the Martin County School Board, reveals that a total of 412 seniors will be graduating in Martin County as the 1972 school year comes to an end.

"The satisfaction is lessened for school people when we realize that there were perhaps 300 others whom our program did not manage to retain," Superintendent Eugene Rogers noted.

A recent highlight event was "A Happening" on May 22 when school patrons, central office personnel, principals, teachers and students all got together to voice their support for a one cents sale tax and the bond referendum for Martin County schools. The bond issue is due for a vote in the county on July 11.

A pilot kindergarten program for Martin County will be at Church Street School in the coming school year. A total of 46 students will be enrolled in the initial program. They are to be selected by the Learning Institute of North Carolina from applications received.

One male and seven female teachers are retiring from the Martin County School system this year. These are Don Chance and Mrs. J. D. Cherry, Mrs. Leila Bond, Mrs. Rebecca Keeyes, Mrs. Ruth Downing, Mrs. Nora Slade, Mrs. Alma Gaither, and Mrs. Symura Fagans.

The Vacation Church School of Hooker Memorial Christian Church will begin Monday and continue through Friday, June 9. Sessions will be scheduled from 9-11:30 a.m. daily. Children from three years old through sixth grade are invited to attend. The theme for this year will be "God's People Must Choose."

School Financing Plan Again Hit

PHOENIX, Ariz. (AP) — A Superior Court judge struck down Arizona's property tax system of school financing, but delayed implementation of his ruling to give the state legislature time to develop another method.

The property tax system is unconstitutional because it favors the wealthy and discriminates against poor school districts, Judge Charles Hardy ruled Thursday.

The system violates the equal protection provisions of both the state and federal constitutions, he said.

The individual class session topics are as follows: Nursery, "It's Summer—and We're Three"; Kindergarten, "Love One Another"; Grades One and Two, "Hi, Neighbor"; Grades Three and Four, "We Need Each Other"; and Grades Five and Six, "Choose!"

Mrs. Esther Warren will serve as director of music. Mrs. Jane Laughinghouse will be the recreation director with several boys and girls as assistants. Refreshments will be served by Mrs. Jane Collie, Mrs. Betty Akin and their assistants.

Vacation Church School will begin at 9 a.m. in the sanctuary with an offering which will be given to aid the Red Oak Christian Church. There will be a devotional time by the Rev. Bob Hufford.

The School this year is being directed by Mrs. Janet Alligood.

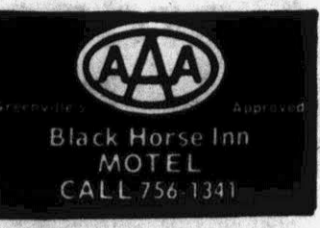

Tonight Skipper Bowles Discusses The Issues

In a 30 minute informative program.

Tonight 10:30 P.M.

on **WNCT-TV Channel 9**

Vote Bowles June 3

Paid for by Committee for Bowles for Governor

North Carolina stands on the edge of greatness

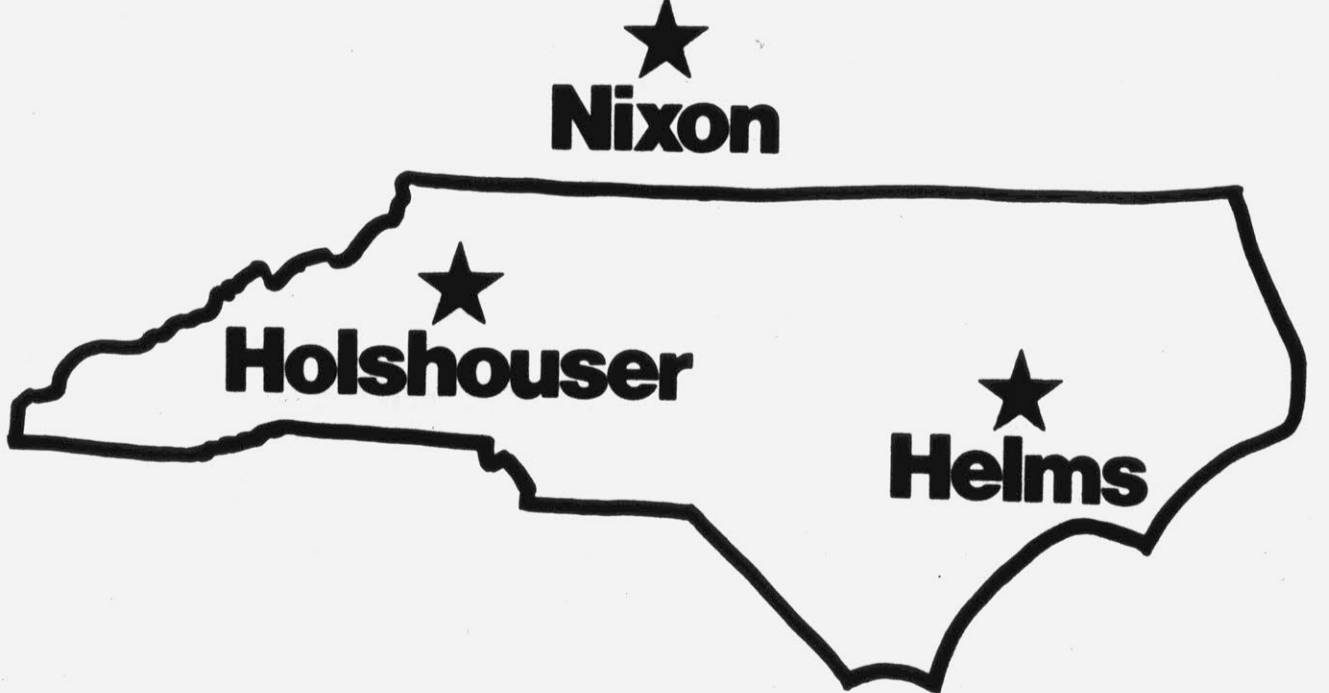

Vote the balanced ticket

...vote Jim Holshouser

in the Republican run-off June 3rd

The President trusts him... so can you.

PAID FOR BY FRIENDS FOR HOLSHOUSE
MRS. JANE DOBY, TREASURER

GALIFIANAKIS OR JORDAN?

Medically speaking, it is a proven fact as we grow older our mental alertness and reflexes slow down. I feel that the next 6 years facing our nation will probably be the most critical years this nation has ever faced. We need an extremely alert Senator at both the beginning and end of this 6 year period, therefore, I plan to vote for Nick Galifianakis.

Although I do not agree with all of his policies, I can not help but believe it is better to have a more active person representing us in the United States Senate than one who is "slowing down" or possibly some "unknown quantity" appointed by some future Governor.

I plan to vote for Nick Galifianakis!

Sincerely,
Ray D. Minges, M.D.

Sleep-Outs In National Parks Loom As A Problem

By PAUL ROBBINS
PROVINCETOWN, Mass. (UPI) — Jim Hankins has been with the National Park Service for 14 years and has seen little or no trouble with illegal sleepers on park lands. He may be in for a new experience.

only leave garbage in some places but add little to the economy or beauty of the area. Favorite targets for the sleepers are the sandy beaches or wooded sites at a roadside rest area.

The roadside sleepers, who plague the Cape area apparently aren't as much of a problem elsewhere across the country, according to a UPI survey of state and local police, park officials and other recreation area authorities. The eastern tip of New York's Long Island may be the worst spot aside from Cape Cod although authorities in California also have had some trouble with the roadside campers from time to time in the Big Sur and Monterey Peninsula areas.

Some Are Tough
"Normally if you find someone sleeping where they shouldn't be, violating a law, you just point it out to them and they move along," the 40-year-old Hankins explained. "You're going to run into your hard core who don't care for anyone or anything and your potential for trouble is always there. But most people are generally cooperative."

Business Considerations
"We on the Cape have to be concerned with the beauty of the area," Frucci said, charging the sleepers "damage the economy as well as the beauty." On Nantucket Island, which is about 30 miles off the mainland and another lure for sleepers, officials passed an islandwide no-sleeping in public places law two years ago. Sgt. Paul Smith of the Nantucket police said authorities enforced the law at the start and when the get-tough policy became known the sleepers dwindled, so did the

arrests. Memorial Day weekend is generally accepted as the "starting gun" for the sleepers invasion, officials agreed, but some young sleepers jumped the gun this year.
Two Typical 'Sleepers'
Peter and Brad, a pair of 16-year-old sophomores from Medfield, Mass., were hitchhiking the other day with a sign that said simply: "Cape." They had just dropped out of a prep school in suburban Boston, they said, and were headed to a friend's family home on the

Cape. Their parents didn't know they had dropped out with just a couple of weeks to go in school.
What would they do and how long would they stay? Brad adjusted his lightweight backpack and sleeping bag and said they figured to stay "maybe until June. We really dunno."
Peter indicated they wouldn't be staying much longer than that, though, because they had a job set on a farm in Monkton, Md. When? "Whenever we get there," they said.

hassle—they showed up with the truck and we cleaned up. When we left, it was cleaner than before."

'Bird Pill' For Dutch Pigeons

ROTTERDAM (AP) — The municipality of Rotterdam began netting pigeons last February to rid itself of the nuisance birds.

But the city is keeping a close watch on the pigeons in another Dutch city, Amsterdam, where pigeons are being fed special food containing substances that interfere with their breeding.

If Amsterdam's 'bird pill' works, Rotterdam may adopt pigeon family planning, according to Rotterdam's informative service.

Next Book May Be On Heartburn

PORT ELIZABETH, South Africa (AP) — Heart transplant pioneer Prof. Christiaan Barnard has written a book called "Heart Attack." His former wife is in print with a volume about the breakup of their marriage titled "Heartbreak."

Dr. Marius Barnard, a heart transplant surgeon like his brother, quipped in a speech here recently that he plans a book called "Heartburn."

FRAUD GOES REMOTE

MBABANE, Swaziland (AP) — Police in the remote mountain kingdom of Swaziland have found it necessary to organize a Fraud and Vice Squad.

Hankins supervises day and night patrols of the woodlands and vast beaches, including the famed dunes outside this tip-of-the-Cape community. He estimated beaches make up about one-third of the 22,000 acres under his jurisdiction.

"If a fellow walks into the dunes with his sleeping bag—he doesn't leave a vehicle, say—and wants to spend the night, he could get away with it," the ranger said, "but we've got these nighttime patrols, so they always run the risk of getting caught. At the same time, if someone wanted to, he probably could hide out in the dunes without us knowing about it."

Hankins said his staff has advised him the sleeping bag brigade has posed little problem in the past and he doesn't look for trouble this summer. Michael Frucci, executive secretary of the Cape Cod Chamber of Commerce, has a different view, however.

"It's a problem and has become an increasingly more serious problem," he said. "Sleepers not only pose a sanitation problem, but also sometimes represent an invasion of privacy by sleeping on personal property when a landowner might not want them



IN SLEEPING BAGS and under blankets, young people crowd a lakeside area in this 1971 Memorial Day weekend photo. (UPI Telephoto)

Laser Given Longer Life

MOUNTAIN VIEW, Calif. (AP) — A sunlight-powered laser that provides the long life required for practical space communications systems has been developed by GTE Sylvania Incorporated, it has been announced.

By means of lenses and mirrors, the new device collects and focuses rays of the sun. The rays stimulate material in the laser to produce beams which can carry voice, data, television and other communications.

Dr. Donald E. Caddes, manager of the company's Electro-Optics Organization, said that the limiting factor of space communications' lasers has been relatively short life.

"Present lasers are powered by electric discharges or lamps and are not yet capable of operating the required 5 to 7 years in a communications satellite," he explained. "The sun-powered laser promises to provide not only the necessary longevity, but economies of weight and size as well."



EVACUATED FROM KONTUM — A wounded woman on stretcher is loaded into a U.S. Army Chinook helicopter during evacuation of wounded at the besieged central highlands capital of Kontum. Stretcher-bearers are soldiers with minor injuries who also hope to find a place on the helicopter. The airport is frequently under North Vietnamese shelling (AP Wirephoto)

DID YOU KNOW ?

...that Senator B. Everett Jordan is Chairman of the Senate Rules Committee, is second-ranking Democrat on the Senate Public Works Committee and is third-ranking Democrat on the Senate Agriculture Committee?

...that Congressman Galifianakis ranks 30th out of 33 Democrats on the House Appropriations Committee?

NOW YOU KNOW! VOTE JORDAN

Committee To Re-elect Senator Jordan
Cliff Everett, Jr., Chairman

PAT TAYLOR tells it like it is!

PAT TAYLOR is fighting "for a decent future for the average citizen of North Carolina." This is his program . . . for your future and your children's future . . . for North Carolina's future; a program that responds to the real needs of your family and thousands of others across this state . . . needs that Pat Taylor's opponent has virtually ignored during this campaign.

- Your Schools**
- More staff help and smaller classes so that teachers can teach and children can learn.
 - Order and discipline which are essential to education.
 - Statewide public kindergartens.
 - The kind of salaries it takes to attract and keep the kind of teachers you want for your children.
- Your Protection**
- Better-trained, better-paid law enforcement officers.
 - A better court system for faster, firmer administration of justice.
 - A complete overhaul of the juvenile corrections system to help troubled young people before they become hardened criminals.
- Drugs and Your Children**
- A "Lindbergh Law" approach to the people who would poison your children for profit — the suppliers of illegal hard drugs — increasing the penalty to a maximum of life imprisonment . . . not against misguided teenagers, or addicts feeding their habit, but against the cold-blooded businessman who supplies the drug traffic.
 - A consistent, factual, effective drug information program throughout the public schools.
- Automobile Insurance**
- Putting state government on YOUR side when your insurance is cancelled by a computer.
 - Fairer administration of the point system for motorists whose jobs require them to drive thousands of miles more each year than the average motorist.
 - Legislation to hold down auto insurance costs.
- Your Health**
- Incentive programs to get doctors to locate in areas of critical shortage.
 - Expansion of the state's medical schools.
 - Expansion of the East Carolina Medical School to specialize in training "family" doctors.
- Taxes**
- Pat Taylor has made these promises about taxes:
- No new or additional taxes on low and middle-income taxpayers, the more than 90 percent of North Carolinians who are already paying more than their share of taxes.
- He Needs Your Help!**
- These are the things Pat Taylor is fighting for in this campaign — things that affect your chance to earn a good living, your children's chance for a good education, your health and safety, and the kind of state we'll have four years from now.
- He's fighting against most of the state's political establishment, who told him to quit.
- He's fighting against most of the people who've been running things for most of the last 12 years . . . and against the slickest, most expensive campaign in the history of North Carolina politics.

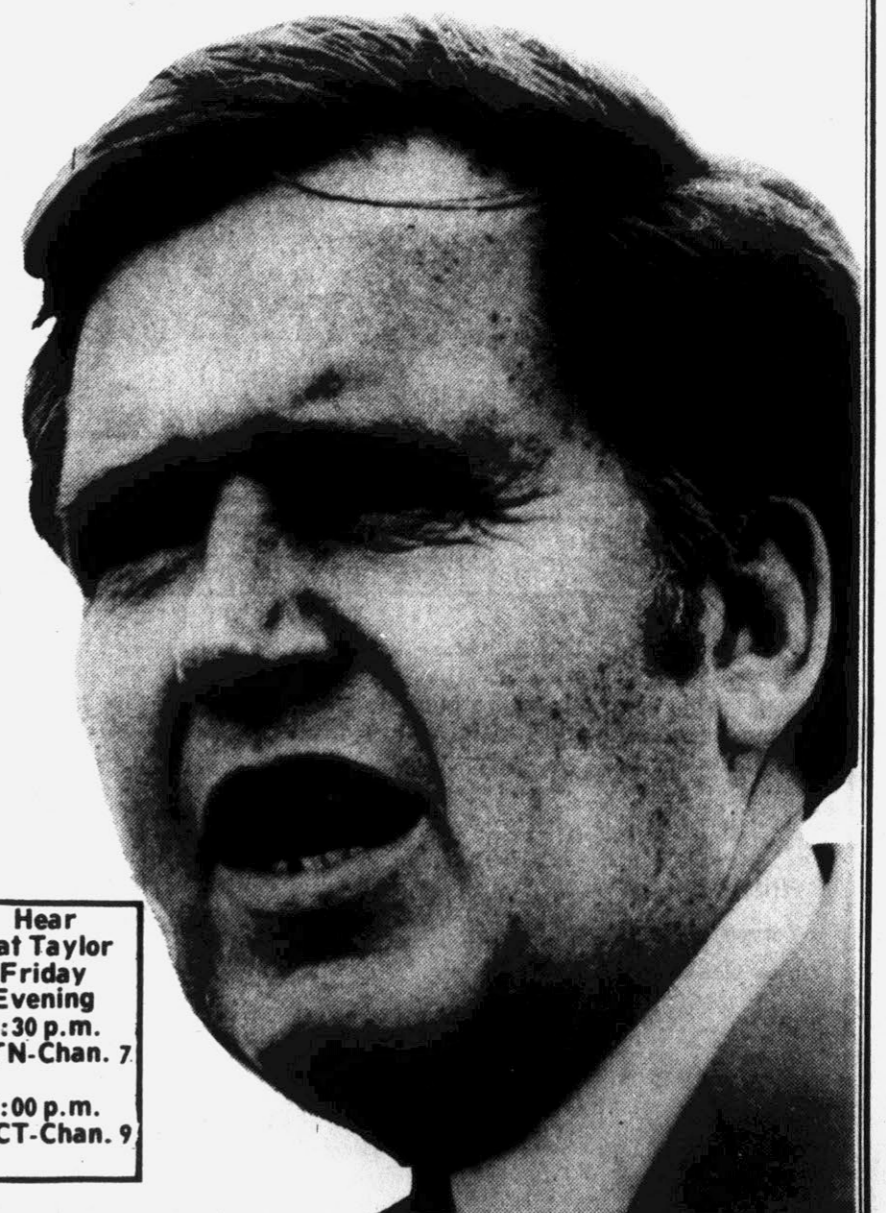

It's NOT just Pat Taylor's fight. It's your fight, too.

Hear Pat Taylor Friday Evening 8:30 p.m. WITN-Chan. 7

9:00 p.m. WNCT-Chan. 9

Paid for by Pat Taylor For Governor Committee
Lindsay Warren, Jr., Chairman

SAVE IN '72 with J.W. DANT

136 YEARS OF AMERICA IN EVERY BOTTLE. WHY DOESN'T IT COST MORE?

J. W. DANT KENTUCKY BOURBON "Grab a full of real bourbon here!" 100 PROOF \$325 Pint \$515 Fifth	J. W. SCOTCH BLENDED SCOTCH WHISKY The Bonus Scotch 86 PROOF \$275 Tenth \$515 Fifth
J. W. DANT GIN 100% GNS The mellow one. 80 PROOF \$225 Pint \$355 Fifth	J. W. DANT KENTUCKY BOURBON WHISKEY "Good honest bourbon at a good honest price." 86 PROOF \$295 Pint \$470 Fifth
J. W. DANT VODKA 100% GNS The Soberable Vodka 80 PROOF \$225 Pint \$355 Fifth	J. W. DANT DISTILLED LONDON DRY GIN \$225 Pint \$355 Fifth

THE PEOPLE'S CHOICE J.W. DANT

© J.W. DANT DISTILLERS CO., N.Y., N.Y.

Come to Church

CHRISTIAN SCIENCE CHURCH
Fourth at Meade Street
11:00 a.m.—Sunday School
11:00 a.m.—Sunday Service
7:45 p.m. Wed.—Evening Meeting
2:00-4:00 p.m.—Reading Room, 313 Evans Street, open daily except Sundays and legal holidays.

JARVIS MEMORIAL UNITED METHODIST CHURCH
510 South Washington Street
Troy J. Barrett, Minister
Charles M. Smith, Associate Minister
Adrian E. Brown, Parish Visitor
7:30 a.m.—The Protestant Hour, WNCN Radio
9:00 a.m.—Holy Communion, Mr. Smith
9:45 a.m.—Church School for all ages
11:00 a.m.—Divine Worship, Mr. Barrett
10:00 a.m. Mon.—WCSA Circles Meet
No. 1—Mrs. R. E. Laughter, Chm., with Mrs. Laughter, 2201 E. 5th St.
No. 2—Mrs. Howard Mims, Chm., with Mrs. Tom Patterson, 1003 E. Rock Spring Rd.
No. 3—Mrs. R. W. Stark, Chm., with Mrs. J. H. Harrell, 901 E. 5th St.
No. 4—Mrs. J. E. Clement, Chm., with Mrs. W. H. Taff, Jr., 308 Granville Dr.
No. 5—Mrs. Clara Moye Shackell, Chm., in the Chapel
No. 6—Miss Elizabeth Wilson, Chm., in the Church Parlor
No. 7—Mrs. Etta Gill, Chm., in the Conference Room
No. 8—Mrs. W. M. Reading, Jr., Chm., with Mrs. H. L. Ormond, Sr., 1704 E. 5th St.
No. 9—Mrs. Jack Moye, Jr., Chm., in the Conference Room
No. 10—Mrs. W. S. Goodson, Chm., with Mrs. Reginald Gray, 502 Westchester Dr.
Wesleyan Service Guild—Miss Louise Williams, Pres., in the Church Parlor
3:30 p.m. Mon.—Brownie Scouts in 7th Grade Room
6:30 p.m. Tues.—Methodist Men
8:00 p.m. Tues.—Administrative Board
10:00 a.m. Wed.—Prayer Group
7:30 p.m. Wed.—Chancel Choir Rehearsal
8:00 p.m. Wed.—Prayer Group

ST. PAUL'S EPISCOPAL CHURCH
Trinity I
The Rev. Lawrence P. Houston, Jr., Rector
The Rev. John A. Winslow, Assistant
The Rev. William J. Hadden, Jr., Chaplain
7:30 a.m.—Holy Communion
11:00—Family Eucharist at Camp Leach
7:00 and 10:00 a.m. Thurs.—Holy Communion

HOOVER MEMORIAL CHRISTIAN CHURCH
1111 Greenville Blvd.
The Rev. Robert G. Hufford Pastor
June 4-10
9:45 a.m.—Church School (nursery)
11:00 a.m.—Church at Worship (Sermon "Eternal Tents" Nursery provided for small children)
6:30 p.m.—Bible Study
9:00 a.m. Mon.—Vacation Church School
8:00 p.m.—Circles III and V with Mrs. Dennis Warren
9:00 a.m. Tues.—Vacation Church School

8:00 p.m.—Circles IV and VI at the church
9:00 a.m. Wed.—Vacation Church School
9:00 a.m. Fri.—Vacation Church School
8:00 p.m. Wed.—Adult choir practice

NAZARENE F. W. B. CHURCH
219 West Eighth Street
Quartely Meeting
8:00 p.m. Fri.—Business Conference
12:00 noon Sat.—Baptism Service
8:00 p.m. Sat.—Holy Communion
9:45—Sunday School
11:00 a.m.—Message by the Pastor
2:00 p.m.—Dinner will be served
9:30 a.m. June 5th—Vacation Bible School will begin and will run through June 9th
8:00 p.m. Thurs.—Prayer Meeting
Rev. Lillian G. Harris, Pastor
Rev. James Harris, Asst. Pastor

ST. JOHN BAPTIST CHURCH
Falkland
Rev. J. R. Person, pastor
6:30 p.m. Sat.—Mission Circle
10:30 a.m.—Sunday School
6:30 p.m.—BTU
8:00 p.m.—Rev. Matthew Best Jr. will preach

HADDOCK CHAPEL CHURCH
10:00 a.m.—Sunday School
7:30 p.m.—Elderess Essie Jones will preach
7:30 p.m. June 5—The church will observe its anniversary

SELVIA CHAPEL F.W.B. CHURCH
1701 South Greene Street
Rev. J. B. Taylor, pastor
7:30 Fri.—Quarterly Conference
9:45 a.m.—Sunday School
10:00 a.m.—Morning Worship (Quarterly meeting)
3:00 p.m.—Fellowship service with Cornerstone M.B. Church, Rev. W.B. Moore, pastor
7:30 p.m.—Holy Communion
7:30 p.m. Tues.—Gospel Chorus rehearsal
7:30 p.m. Wed.—Prayer meeting

ST. JAMES METHODIST CHURCH
8:45 a.m.—The Worship of God
9:45 a.m.—Church School
11:00 a.m.—The Worship of God
2:00 p.m.—Adult Discussion
Sunday School Class bus trip to James Hudson's Bayview River house
9:00-12:00 Mon, Fri.—Vacation Church School for eight year old through the eleven year olds (third grade through the sixth grade)
7:00 a.m. Mon.—Christian Growth Group (Rodgers)
8:00 p.m. Mon.—Circle no. 1 (Selma Rogers)
Circle no. 2 (Betty Yancey)
Circle no. 3 (Bett Hayes)
Circle no. 4 (Deanie B. Haskett)
7:00 a.m. Tues.—Christian Growth Group (Hodges)
10:00 a.m.—Circle no. 7 (Myra Hodges)
Circle no. 8 (Bet Tyler)
Circle no. 9 (Audrey James)
7:30 p.m.—Softball game, St. James vs. Maranatha (Evans Park)
8:00 p.m.—Christian Growth Group (Library)
7:30 p.m.—Wed., Thurs., Fri.—Softball game St. James vs. Black Jack (Evans Park)
Monday-Thursday—North Carolina Methodist Annual Conference in Durham

MEMORIAL BAPTIST CHURCH
Fourth and Greene Streets
C. Norman Bennett, Jr.

LUTHERAN CHURCH OF OUR REDEEMER
1801 South Elm Street
R. Graham Nahouse, Pastor
Trinity I
8:30 a.m.—The early Service
11:00 a.m.—The Service with Holy Communion
9:00 a.m. Mon.—Vacation Church School begins. Classes each day at 12 noon for nursery through sixth grade.
6:00 p.m. Fri.—Vacation Church School commencement and fellowship supper
Our Redeemer Lutheran Church Kindergarten is now registering for the fall term. Mrs. Faye Baker is the teacher. Call 756-2058 or 752-5206 or write P. O. Box 2946

OAKMONT BAPTIST CHURCH
E. Gordon Conklin, Pastor
408 Lee Street
Cherry Oak
9:45—Sunday School
11:00—Morning worship
5:00—Senior High Group Meeting
9:00-11:30 a.m. Mon.—Vacation Bible School - June 5-9. Ages 3 to Grade 6.
5:30-7:45—Junior High - Each Evening
7:30 Tues.—Boy Scouts Troop 124
6:30 Wed.—Family Supper at Church

FIRST PRESBYTERIAN CHURCH
Fourteenth and Elm
9:00 a.m.—Morning Worship
9:45 a.m.—Sunday School
11:00 a.m.—Morning Worship (This service broadcast weekly over WNCN AM)
5:30-7:45—Junior High - Each Evening
7:30 Tues.—Boy Scouts Troop 124
6:30 Wed.—Family Supper at Church

UNIVERSITY CHURCH OF CHRIST
Lawrence R. Kepler, Minister
Sunday June 4: Meeting at New Austin Building on E. C. U. campus.
10:00 a.m.—Sunday School
11:00 a.m.—Morning Worship and Communion
7:30 p.m.—Vacation Bible School Program
Tuesday June 6: Meeting at Pitt Tech.
6:30 p.m.—Elders Meeting
7:30 p.m.—Church Board Meeting
Wednesday June 7: Meeting at H.C. Davis, Glenwood Acres
7:30 p.m.—Prayer Meeting
7:30 p.m.—Youth Meeting

FIRST CHRISTIAN CHURCH
520 E. Greenville Blvd., M. Dana Hunt, Minister
Richard A. Rintamaa, Minister of Education
9:00 a.m.—Morning Worship Service
10:00 a.m.—Church School
11:00 a.m.—Morning Worship Service
6:00 p.m.—Youth Groups
7:30 p.m.—Bible Fellowship
Monday June 5: Friday June 9, 1972—Vacation Church School
3:45 p.m. Mon.—C.W.F. Circles, Brownie Scout Troop 122
7:00 p.m.—C.W.F. Circles, Cadette Scout Troop 394
7:30 p.m. Tues.—C.W.F. Circles, Official Board
7:30 p.m. Wed.—Chancel Choir
7:30 p.m. Thurs.—Explorer Post 433

HOMES FOR AMERICANS

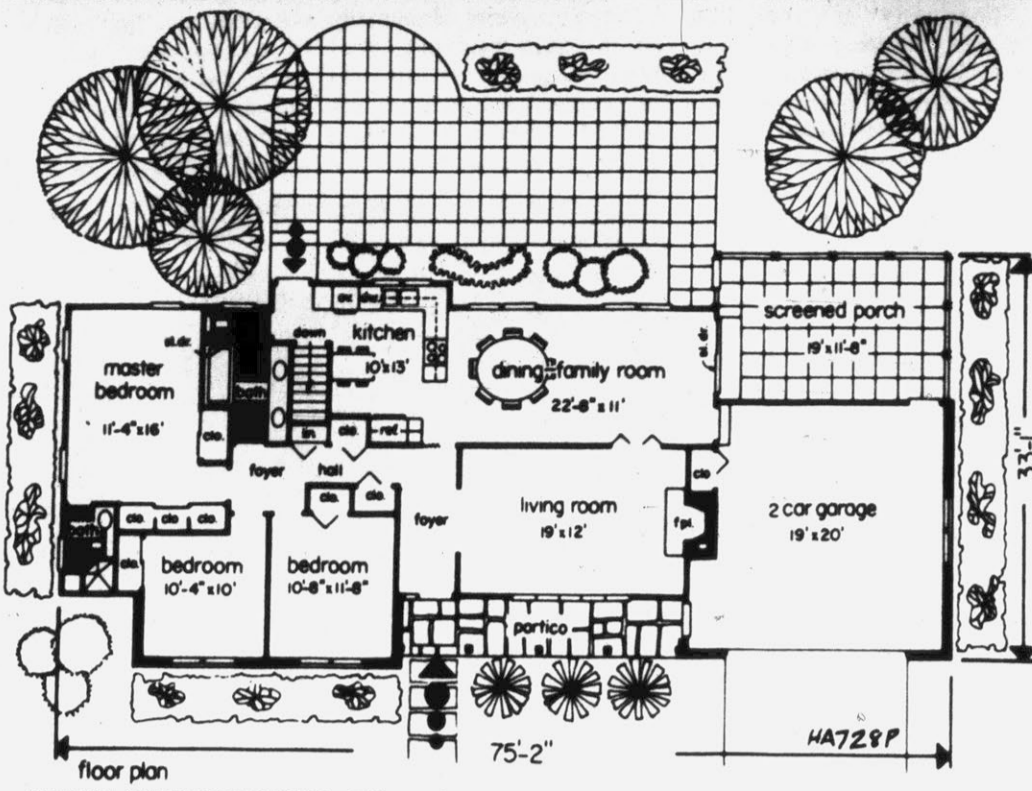
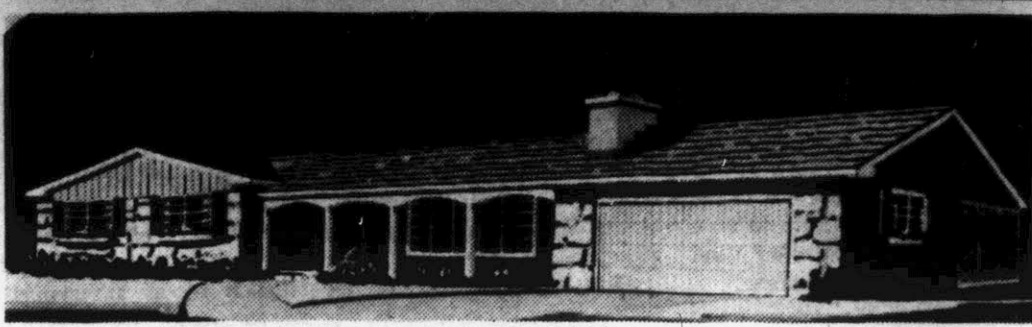

THREE BEDROOM RANCH: This modest home looks large because of its layout and two-car garage. With a 75-foot front it takes 1,474 square feet. The kitchen and dining room stretch across much of the rear to a screened porch. A hall off the front foyer leads to the three bedrooms and two baths. The exterior is a tasteful blend of stone veneer and vertical boards. Plan HA 728P was designed by architect Samuel Paul, 107-40 Queens Blvd., Forest Hills, N.Y., 11375. For information regarding blue prints write the architect.

Bonus Enlistment Plan Set By Army

The Army announced a special bonus plan, calling for payment of \$1,500 for a four-year enlistment, for young men enlisting in certain careers in the infantry, armor and artillery.

According to local recruiters, Sgt. David Hughes and Sgt. George Washington, the bonus is payable in full following successful completion of basic and advanced training. This normally occurs about four months after enlistment, depending on the career field selected, they said.

Men with prior service are eligible for the bonus plan, it was noted, if they have less than three years active service, have not previously received a reenlistment bonus and meet certain other requirements.

Besides professional training, the recruiters reported, young men in the bonus plan will also be eligible to volunteer for the widest range of enlistment

travel options ever offered by the Army. They include guaranteed assignments in Europe, Alaska, Hawaii, the Far East and Panama, as well as units of choice in different parts of the United States.

The Army spokesmen said that the enlisted man now starts at \$288 a month, with increases following basic training. The Army also offers the traditional benefits of free meals, housing, clothing medical and dental care, and 30 days paid vacation a year.

The recruiters said that persons seeking further information should call them at 752-4826 or stop by the recruiting office at 323 Evans Street.

More than 200 commercial crops are grown in California, says the California Farm Bureau.

Memorial Baptist Church
Corner Of 4th and Greene Streets
REV. C. NORMAN BENNETT, JR.
PASTOR
Sunday School 9:45 a.m.
Morning Worship 11:00 a.m.
(Nursery Available)

Where Russell Secret and his opponent stand on the important issues in the race for Commissioner of Insurance.

Russell Secret	John Ingram
Will fight for a constitutionally sound, modified no-fault auto insurance system because recent reports from Massachusetts and Florida show that no-fault has reduced rates in those states and will be in the best interest of all North Carolina motorists.	No-Fault Insurance. Opposes a no-fault insurance plan.
Will use the authority of the commissioner's office to force companies to provide voluntary coverage for older people, younger people—all drivers with a reasonable driving record; will also force companies to remove those drivers from the assigned risk plan who do not belong there.	The Assigned Risk Plan. Would seek to abolish the assigned risk plan, leaving hundreds of thousands of motorists with no liability insurance and therefore unable to drive their cars.
Would use the authority of the commissioner's office to appoint a special study committee to investigate the high cost of hospital and medical insurance because he feels strongly that the people must be able to purchase health insurance at a reasonable price.	Hospital and Medical Insurance. No position.
Would use the resources of the Insurance Commissioner's office to strengthen these invaluable training programs that protect the lives and safety of thousands of North Carolinians.	Firemen and Rescue Squad Training Programs. No position.
Would install a toll free telephone so that every citizen could communicate directly with the Insurance Commissioner on any insurance problems he may have.	Consumer Protection. No position.
Would oppose any effort to increase the premium tax on insurance policies since such taxes are paid by the consumer.	Life Insurance. No position.

This comparison shows clearly that Russell Secret is the only candidate with a positive program to deal with all the insurance needs of North Carolina. This comparison also shows that his opponent does not have a program, but is merely seeking to win on a single, irresponsible promise.

Russell Secret can offer a positive program for our insurance needs because he is the most experienced candidate. Most of his 16 years in the Department of Insurance were spent policing insurance agencies, making them toe the mark, putting them out of business when they did not, and reprimanding insurance companies when they did not act in the public interest.

Russell Secret is the only candidate who will bring reasonable, responsible leadership to the Insurance Department. Please vote for him on June 3rd.

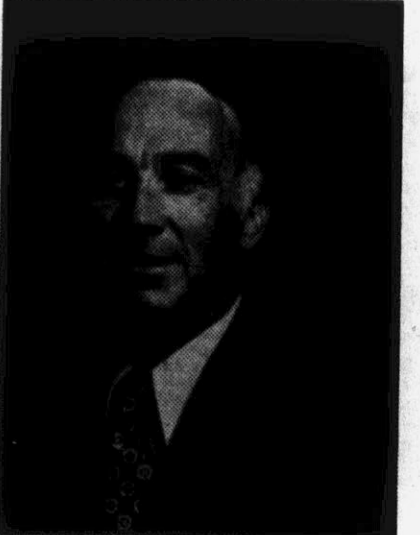

Russell Secret

For Reasonable, Responsible Leadership To Solve Our Insurance Problems.

It's pretty evident that we have toppled the little red schoolhouse. Ideas we had about economics, science, race and education itself, have come and gone. New ideas are broaching the surface of life and thundering over us.

Campus unrest and street demonstrations make us reappraise old values and ideas.

But one idea remains steadfast. It is the idea that God loves man and men, and that He cares about what happens to our lives.

Are shouting television newscasts and bold headlines overwhelming you? Then you need an open mind and a steady faith. God's love is for you. Your church is where you find out about it. Try it next Sunday. It will help you grasp an old idea, even if it is a new one for you.

Ideas... Old and New

Copyright 1972 Kestler Advertising Service, Inc., Strasburg, Virginia
Scriptures selected by the American Bible Society

Sunday	Monday	Tuesday	Wednesday	Thursday	Friday	Saturday
Luke 22:39-46	Job 8:11-18	Psalms 22:1-11	Psalms 52:1-9	Psalms 77:1-9	Psalms 83:1-18	Psalms 137:1-9

This series of ads is being published each week in The Reflector and is being sponsored by the following individuals and business establishments:

- Pitt FCX Service
- Farmer's Headquarters
- Corner Line and Chestnut Street
- Home Savings and Loan Ass'n
- Deposits Insured up to \$20,000
- 543 Evans Street — Phone 758-3421
- Biggs Drug Store
- Prescriptions Carefully Compounded
- 300 Evans Street — Phone 752-2136

Independence To Solution To Needs Of Bangladesh

DACCA (UPI)—Their nation's newly won independence has not changed and perhaps never will change life in the villages of the vast riverine delta that is Bangladesh.

Life has always been a struggle for survival. It remains so.

The tradition of timeless changelessness associated with so much of Asia is nowhere

more marked than in these villages and the land their people work.

Variation in season is imperceptible, marked only by the rains of the monsoon and the rising waters that flood the land and deposit their fertile burden of silt to nourish the rice of future years.

It is flat land, the flattest country on earth, 80 per cent of

it no more than a few feet above sea level. To fly over it is to experience the monotonous repetition of meandering waterways, villages and paddy. To drive through it, or walk, or take a country boat along the brown rivers is to appreciate its endless variation and beauty.

Villages are clusters of thatched roofs, the corners

characteristically dropping to allow the run-off of heavy rains. Each is usually set around a reservoir dug both to provide water for cooking, washing and irrigation, and to build an earth fill on which houses can be raised to protect them from floods.

The villages are shaded by jackfruit and mango trees. In drier areas clumps of bamboo flourish, providing building materials for huts and cattle sheds.

The staple food is rice, cooked with a little salt and eaten with curry spices and perhaps some scraps of potatoes, cabbage or lentils. On rare festive or religious occasions roast or curried meat is eaten.

Almost every year millions of peasants go hungry during the month before harvest when the rice stocks run out. Then wheat is eaten cooked in flat pancakes called chupatis, or stew is made of water lily roots.

Landless laborers eke out a living on a wage of about two rupees (28 U.S. cents) a day. The work is tasks like the transplanting of rice, ankle-deep in mud and bent double in the hot sun, or plowing behind a team of buffalo.

In some places two or even three crops may be grown a year. But where only one crop is possible because of lack of water, a man has nothing to do for much of the year. Much time is spent in the village tea shop discussing village politics and prices.

So life goes on from generation to generation in the 71,291 villages of Bangladesh, changed only by the increasing pressure of population on the land.

About 85 per cent of the 75 million people of Bangladesh are peasant farmers, the highest rural population in the world. They are spread across fertile paddy lands about the size of the state of Arkansas at an average density of more than 2,000 per square mile.

There are only 21.50 million acres of paddy for some 14

million cultivators, so the average landholding if it were distributed evenly would only be 1.5 acres per family. As a result each farmer produces only about 15 per cent more than his own needs.

Jute is the main cash crop, grown by some 5 million farmers and Bangladesh is the world's largest producer of it. Tea is grown in the northeast and sugarcane in the northwest. Fishing occupies thousands of families, but most of the rural population grow nothing but rice.

Madame Soleil Has The Answers For Listeners

By THEODORE STANGER PARIS (UPI)—At the stroke of midnight, Madame Soleil comes on the air and steers her faithful listeners through the pitfalls of love, divorce, disease, adultery, exams, bankruptcy, unemployment and anything else that may be bothering them.

Madame Germaine Soleil (her name means "sun") is France's, and possibly Europe's, foremost voyante, or fortune teller.

But unlike the thousands of other registered practitioners of the occult, this portly, middle-aged matron steers away from time-worn trappings like crystal balls, amulets and stuffed owls. Nor does she trouble with predictions of movie star divorces or the daily double winner.

Instead, Madame Soleil holds forth with her own radio program on Paris' Europe One station where, for the first hour of every new day, she receives telephone calls from troubled fans all over France.

With the lulling strains of Grieg's "Morning" symphony—

her theme music—playing in the background, Madame Soleil picks up the phone to commune with her first caller.

Forlorn Besech Her "Madame Soleil," comes an often forlorn voice, "What should I do?"

With that one eternal question, a common denominator to all her callers, Madame Soleil personally takes the case in hand and points out the path to salvation.

Madame Soleil rarely relies on the stars for an answer to earthly worries. She prefers plain, old-fashioned horse sense.

To the countless women callers on the verge of tears who tell Madame Soleil they have at last decided to abandon their husbands, she first inquires in whose name the house and common property is under.

To one desperate wife who sobbed her husband beat her regularly, Madame Soleil advised desertion—and now!

"But my maternal aunt said I ought to try to stay with him..." the woman replied.

"Is it your maternal aunt

who gets beaten?" Madame Soleil snapped back. "Leave him."

Her feet planted firmly in reality, Madame Soleil advocates recourse to lawyers (she keeps a referral list), police (when necessary) and good doctors.

Advice Runs Gamut She advises against large families (too costly), favors tidy personal appearance (first impressions) and staying on good terms with grumpy relatives (easier in the long run).

To the flocks of divorce-bent women who telephone, Madame Soleil prudently reminds that divorce proceedings take money.

As for adultery, Madame Soleil's stand is clear: she is for it.

To women who fear their husbands have forgotten them, Madame Soleil openly prescribes a measure of "playing the field."

The show's regular listeners are probably attracted by juicy, first-hand accounts of desertions, beatings, adultery and human misery—all rich in listening thrills.

Madame Soleil is hardly the only celebrated fortune teller in France. Paris voyantes alone do a \$12 million a year business, according to city officials.

But Soleil is the only fortune teller to have been singled out by the president of France.

President Georges Pompidou, in reply to a newsman's question about the political future, once said, shrugging his shoulders, "I am not Madame Soleil."



MADAME SOLEIL comes on the air at the stroke of midnight to guide her faithful listeners. (UPI Telephoto)

Stokes Student On Dean's List

RALEIGH — Kathy Elaine Bullock of Stokes has been named to the dean's list at Peace College for the spring semester.

Miss Bullock, a rising sophomore at the Raleigh junior college, is the daughter of Mr. and Mrs. Darrell Bullock of Rt. 1, Stokes.

Election to the dean's list requires an academic average of B-plus or better.

One egg from a type of parasitic wasp divides to produce either 24 males or 16 females.

Army Closing 3 Drug Centers

SAIGON (AP) — The U.S. Army is closing three of its drug rehabilitation centers in Vietnam, the U.S. Command announced today.

"We just don't have enough troops left in Vietnam to justify keeping them open," a spokesman said.

The Army will continue to operate the center at Long Binh, 12 miles northeast of Saigon. A total of 64,800 American troops were reported in the country last Thursday, but this is scheduled to be reduced to 49,000 by July 1.

THEY CAME TO ZAMBIA

LUSAKA, Zambia (AP) — Zambia gained 7,661 immigrants in 1971, a record total for any one year since independence in 1964. The largest number—2,786—came from Britain to the former British territory of Northern Rhodesia.

Prize Incentive

KINGS MOUNTAIN, N.C. (AP) — A new car and other prizes are being offered by a textile firm to combat absenteeism among its 500 workers.

The Craftspun Yarns Co. says a record will be kept for 12 weeks, beginning next Monday. Workers with perfect attendance and arrival at work on time will have their names entered for a drawing for the first prize—a new car.

Other prizes, also based on drawings, will include a color television set, a stereo set, and a hi-fi set.

The firm is a division of the B.V.D. Co., which makes men's underwear.



FARMERS OF BANGLADESH, using a team of emaciated water buffalo, plow their fields. Independence has not changed their lives and perhaps never will. (UPI Telephoto)

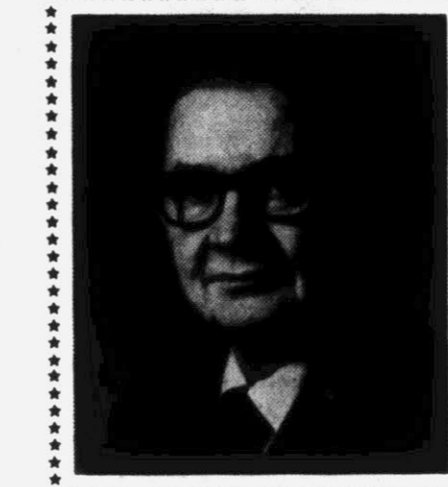

W. C. "BILLY" CREEL
for
COMMISSIONER OF LABOR

30 YEARS EXPERIENCE
IN DEPARTMENT OF LABOR

Your vote and support will be appreciated

DEMOCRATIC PRIMARY MAY 6
Political Advertisement

COMPARE the candidates for U.S. Senate

	Nick Galifianakis	B. Everett Jordan
AGE:	43	75
PROFESSIONAL BACKGROUND:	Practicing lawyer. Assistant Professor of Business Law, Duke University. Officer in U.S. Marine Corps.	Owner of textile mill; World War I veteran.
EXPERIENCE IN PUBLIC OFFICE:	12 years	14 years
NORTH CAROLINA HOUSE OF REPRESENTATIVES:	Elected in 1960; reelected in 1962 and 1964.	0
UNITED STATES HOUSE OF REPRESENTATIVES:	Elected in 1966; reelected in 1968 and 1970.	0
UNITED STATES SENATE:	0	Appointed by Governor in 1958; Elected in 1960 and reelected in 1966.
SENIORITY:	After only four years in the U.S. House of Representatives, was elected to the powerful House Appropriations Committee. Has the respect and potential to achieve meaningful seniority in the years ahead.	Ranks 32nd in seniority among 100 Senators. Has announced he is seeking only one more term, therefore has no possibility of achieving real power in the U.S. Senate.
MAY 6th PRIMARY:	49.2% of vote	44.3% of vote



North Carolina Democrats compared Nick Galifianakis and B. Everett Jordan on May 6 in the Democratic primary.

Congressman Galifianakis came within .8% of winning a clear majority even though there were four candidates seeking the Democratic nomination. The incumbent trailed by nearly 38,000 votes.

The record speaks for itself. We must elect Nick Galifianakis to the United States Senate. It's our future.

LET'S SEND NICK TO THE SENATE

Pitt County Committee For Nick Galifianakis—Leon L. Moore, Jr., Chairman

NOTICE

CHANGE IN OFFICE HOURS

Beginning June 5, 1972

THE OFFICES OF THE
City of Greenville

and
Greenville Utilities Commission

WILL BE OPEN FROM

8:00 A.M. TO 5:00 P.M.

MONDAY THROUGH FRIDAY

District Court

Judge Robert D. Wheeler disposed of the following cases at the May 15-19 term of District Court in Pitt County.

Charlie Reddick, assault on female, 30 days jail suspended pay \$25 and cost.

Roland Leverne Rhodes, speeding, prayer for judgment continued on payment of cost.

Thomas Earl Matthews, Jr., expired inspection, pay cost.

Jimmy Lee Jones, speeding, 60 days jail suspended pay \$25 and cost.

Thomas George Davison, speeding, 30 days jail suspended pay \$10 and cost.

David Lee Barnes, fail decrease speed, not guilty.

Eli Anderson Warren, fail see safe move, not guilty.

Ronnie Lawrence Tripp, driving under the influence, not guilty.

Donald Scott Freeman, no operators license, not pros.

Joseph Brant Hill, driving under the influence, 6 months jail suspended pay \$100 and cost, drivers license revoked 12 months.

Ronald Roy Smith, speeding, not pros, driving under the influence, 6 months jail suspended pay \$100 and cost, drivers license revoked for 12 months.

John Nicholson Hudson, exceeding safe speed, not pros.

Thomas Patrick Randolph, exceeding safe speed, prayer for judgment continued on payment of cost.

Richard Steven Holoman, Jr., driving under the influence, 6 months jail suspended pay \$100 and cost, drivers license revoked 12 months.

Robert Lee Rose, speeding, prayer for judgment continued on payment of cost.

Francis Brown Dunn, speeding, pay \$15 and cost.

John Isaac Prayer, speeding, prayer for judgment continued on payment of cost.

William Thomas Barbour, no operators license, not pros with leave.

William Earl Harris, purchase beer by minor, 30 days jail suspended pay \$25 and cost, not purchase any beer for 2 years.

Stefinus Hemby, careless and reckless driving, no operators license, not guilty.

James Walter Lloyd, allow person under the influence to drive, not pros with leave.

J. D. Ward, assault by pointing a gun, not guilty.

Roy Stevenson Baker, speeding, 6 months jail suspended pay \$25 and cost, license revoked 6 months.

Calvin Daniels Hines, shoplifting, 12 months jail.

Mary Mallon McLean, improper passing, not pros.

Sue Elizabeth Harris Joyner, shoplifting, 30 days jail suspended pay \$10 and cost.

E. Garrett Gaspenini, worthless check (2 counts), 60 days jail suspended pay each cost and each check.

Jasper Clemons, worthless check, 30 days jail suspended pay cost and check.

Willie Phillips, worthless check, 30 days jail suspended pay cost and check.

Elmer Bembridge speeding, 30 days jail suspended pay \$25 and cost.

Alexander Baker, speeding, 30 days jail suspended pay \$15 and cost.

Alvin Jenkins, larceny, not pros.

Donald Chapman, assault, prayer for judgment continued on payment of cost.

Gary Chapman, assault, prayer for judgment continued on payment of cost.

William D. Meeks, assault, prayer for judgment continued on payment of cost.

Dorothy M. Daniels, worthless check (2 counts), 30 days jail suspended pay cost and each check.

Jimmy Junior Strickland, no inspection pay cost.

Kenneth Foy Foscutt, III, speeding, 30 days jail suspended pay \$25 and cost.

William Henry Jenkins, driving under the influence, 6 months jail suspended pay \$100 and cost, drivers license revoked 12 months.

Jessie Cogdell, Jr., improper head lamps, 30 days jail suspended pay \$5 and cost.

Willie Woolard, carry concealed weapon, 30 days jail suspended pay cost, weapon confiscated.

Willie Woolard, driving under the influence, not guilty.

Johnny Ray Vines, violation of liquor law, prayer for judgment continued for 2 years upon payment of cost.

James Benjamin Wadsworth, III, carrying concealed weapon, not pros.

Louise Smith, shoplifting, 6 months jail suspended pay \$50 and cost, probation 2 years.

Lena Shaffer, shoplifting, 6 months jail suspended pay \$50 and cost, probation 2 years.

Dean H. Goehring, manufacturing non tax paid whiskey, 12 months jail suspended pay \$250 and cost, not violate any liquor laws for 3 years, probation 3 years and 1 month.

Davis Lee Sutton, worthless check, 30 days jail suspended pay cost and cost.

Adrian Cox, manufacturing non tax paid whiskey, 12 months jail suspended pay \$250 and cost, not violate any liquor laws for 1 month.

William Edward Byers, aid and abet to speeding and careless and reckless driving, not guilty.

Gene McGowan, temporary taking of vehicle, not pros.

Robert Harrington, public drunk, prayer for judgment continued on payment of cost.

David Lee Sanderson, speeding, prayer for judgment continued on payment of cost.

Ella Morgan, parade without a permit, not pros with leave.

Terrence Clyde Payne, speeding, 30 days jail suspended pay \$15 and cost.

Tommy Lindsay, fail drive on right half of roadway, 30 days jail suspended pay \$15 and cost.

Jessie Earl Gardner, driving under the influence, 6 months jail suspended pay \$100 and cost, drivers license revoked 12 months.

Mac Donald Jones, fail see safe move, 30 days jail suspended pay \$15 and cost.

George Caswell Moye, speeding, prayer for judgment continued on payment of cost.

Andy Earl Futrell, speeding, prayer for judgment continued on payment of cost.

Richard Allyn Gilliland, no inspection, pay cost.

Albert Lee Edwards, driving under the influence, 6 months jail suspended pay \$100 and cost, drivers license revoked 12 months.

Danny Mac Malloy, speeding, 60 days jail suspended pay \$200 and cost, careless and reckless driving, fail stop for blue light and siren, not guilty.

James Benjamin Wadsworth, III, tampering with a vehicle, 12 months suspended pay \$100 and cost, probation 3 years and 1 month.

Walter Anthony Krause, trespass, 6 months jail suspended pay \$100 and cost, probation 2 years.

Paul Bright, assault, 30 days jail, not pros.

Joe E. Olscher, no operators license, not guilty.

Kenneth Lane Smith, speeding, not pros.

Blaine Hampton, illegal fishing, not pros.

George Blocker Pugh, careless and reckless driving, not pros.

Sammy Ray Carmon, assault on female, not pros.

James Carl Adams, speeding, prayer for judgment continued on payment of cost.

Ralph Thomas Gillespi, Jr., speeding, 30 days jail suspended on payment of \$15 and cost.

Alexander Turna Stewart, speeding, prayer for judgment continued on payment of cost.

David Thomas House, III, speeding, prayer for judgment continued on payment of cost.

R. T. Scott, worthless check (4 counts) 30 days jail suspended pay cost and check, continued on probation.

Louis Henry Buck, Jr., speeding, prayer for judgment continued on payment of cost.

James C. Best, driving under the influence, 6 months jail suspended pay \$100 and cost, drivers license suspended 12 months.

John Allen Bynum, speeding, 60 days jail suspended pay \$50 and cost.

Larry Donald Farver, careless and reckless driving, 6 months jail suspended pay \$50 and cost.

Frank Hassett, assault on female, 6 months jail suspended pay \$25 and cost.

Ronald Monk, assault, 30 days jail suspended pay \$25 and cost.

Max Pollard, speeding, prayer for judgment continued on payment of cost.

Hillman Oswald Hudson, driving under the influence, fail see safe move, 6 months jail suspended pay \$100 and cost, drivers license susp. 12 mos.

George Bland Miller, II, breaking and entering, not pros.

Mary Jane Hooks, drunk and disorderly, 30 days jail.

Alice Faye Phillips, forcible trespass, prosecution adjudged frivolous and malicious, prosecuting witness pay cost.

Donnie E. Vick, disorderly conduct, quashed.

Ronnie Vick, disorderly conduct, quashed.

Lelia G. Coltraine, overtime parking, pay \$1 and cost.

Larry Martin Land, speeding, prayer for judgment continued on payment of cost.

Donald Albert Roll, driving under the influence, 6 months jail suspended pay \$100 and cost, drivers license revoked 2 years.

James Eddie Gardner, driving under the influence, not guilty.

William Worsley, driving under the influence, not guilty.

Wayne Jones, speeding, pay \$25 and cost.

Kelly Turner, speeding, prayer for judgment continued on payment of cost.

Sammie Lewis Whitehurst, speeding, prayer for judgment continued on payment of cost.

Warren Trent, breaking, entering and larceny, not guilty.

Clifton Wooten, breaking, entering and larceny, not guilty.

Craig Christian Carson, speeding, prayer for judgment continued on payment of cost.

David Earl Bullock, assault on female, 90 days jail suspended pay \$25 and cost.

Donald Gay Boyd, no inspection, pay cost, cost remitted.

Marcellus Cotton, follow too close, not guilty.

Preston Sims, driving under the influence, 6 months jail suspended pay \$100 and cost, driver license revoked 12 months.

Debra Louis Wilkins, no operators license, not pros.

Clarence Graely Fulton, driving under the influence, 2nd offense, 6 months jail suspended pay \$200 and cost, surrender drivers license, probation 5 years.

Marcey Lynn Mevris, speeding, 30 days jail suspended pay \$15 and cost.

William May, driving under the influence, 6 months jail suspended pay \$100 and cost, surrender drivers license 12 months.

Bobby Wayne Tugwell, careless and reckless driving, guilty of exceeding stated speed, prayer for judgment continued on payment of cost.

Kenneth Morris Ham, driving under the influence, quashed.

John Edward Barnes, driving under the influence, (2 counts), 6 months jail suspended pay \$200 and cost, surrender drivers license 2 years.

John Wayne Wainwright, worthless check, 30 days jail suspended pay \$10 and cost and check.

Boyd Vaughn Payne, driving under the influence, 6 months jail suspended pay \$100 and cost, surrender drivers license 12 months.

Thomas Core, Jr., speeding, 30 days jail suspended pay \$10 and cost.

Leroy Gardner, public drunk, 30 days jail suspended pay \$10 and cost.

Tony Earl Edmondson, improper passing, 30 days jail suspended pay \$10 and cost.

Don Tyson, Jr., driving under the influence, 6 months jail suspended pay \$100 and cost, surrender drivers license 12 months.

Bud C. Anderson, public drunk, 30 days jail suspended pay \$10 and cost, no operators license, not guilty.

Morris Mills Parnell, driving under the influence, 6 months jail suspended pay \$100 and cost, surrender drivers license 12 months.

Hubert Dalma Hines, fail give audible warning when passing, prayer for judgment continued on payment of cost.

James Thomas Lane, driving under the influence, not guilty; speeding, 30 days jail suspended pay \$50 and cost.

Arnold Lee Baker, driving under the influence, 6 months jail suspended pay \$100 and cost, surrender drivers license 12 months.

Ben Foreman, speeding, 30 days jail suspended pay \$25 and cost, surrender drivers license 60 days.

John Edward Barnes, carrying concealed weapon, driving under the influence, not pros.

Maso Worrell, public drunk, not pros.

Edward Bryant Oakley, speeding, prayer for judgment continued on payment of cost.

James Earl Whitley, Jr., worthless check, 30 days jail suspended pay \$10 and cost and check.

license revoked 12 months.

Debra Louis Wilkins, no operators license, not pros.

Clarence Graely Fulton, driving under the influence, 2nd offense, 6 months jail suspended pay \$200 and cost, surrender drivers license, probation 5 years.

Marcey Lynn Mevris, speeding, 30 days jail suspended pay \$15 and cost.

William May, driving under the influence, 6 months jail suspended pay \$100 and cost, surrender drivers license 12 months.

Bobby Wayne Tugwell, careless and reckless driving, guilty of exceeding stated speed, prayer for judgment continued on payment of cost.

Kenneth Morris Ham, driving under the influence, quashed.

John Edward Barnes, driving under the influence, (2 counts), 6 months jail suspended pay \$200 and cost, surrender drivers license 2 years.

John Wayne Wainwright, worthless check, 30 days jail suspended pay \$10 and cost and check.

Boyd Vaughn Payne, driving under the influence, 6 months jail suspended pay \$100 and cost, surrender drivers license 12 months.

Thomas Core, Jr., speeding, 30 days jail suspended pay \$10 and cost.

Leroy Gardner, public drunk, 30 days jail suspended pay \$10 and cost.

Tony Earl Edmondson, improper passing, 30 days jail suspended pay \$10 and cost.

Don Tyson, Jr., driving under the influence, 6 months jail suspended pay \$100 and cost, surrender drivers license 12 months.

Bud C. Anderson, public drunk, 30 days jail suspended pay \$10 and cost, no operators license, not guilty.

Morris Mills Parnell, driving under the influence, 6 months jail suspended pay \$100 and cost, surrender drivers license 12 months.

Hubert Dalma Hines, fail give audible warning when passing, prayer for judgment continued on payment of cost.

James Thomas Lane, driving under the influence, not guilty; speeding, 30 days jail suspended pay \$50 and cost.

Arnold Lee Baker, driving under the influence, 6 months jail suspended pay \$100 and cost, surrender drivers license 12 months.

Ben Foreman, speeding, 30 days jail suspended pay \$25 and cost, surrender drivers license 60 days.

John Edward Barnes, carrying concealed weapon, driving under the influence, not pros.

Maso Worrell, public drunk, not pros.

Edward Bryant Oakley, speeding, prayer for judgment continued on payment of cost.

James Earl Whitley, Jr., worthless check, 30 days jail suspended pay \$10 and cost and check.

Fittingly Enough, Archie Turns To Politics In Next TV Season

By GENE HANDSAKER
Associated Press Writer
HOLLYWOOD (AP) — Archie Bunker will be spouting off about politics when "All in the Family" begins its new season.

It's only natural in an election year. "The whole world will be talking about the election," says director John Rich. "Why couldn't Archie Bunker?" The show itself will take no positions, he added. It will be "an advocacy of character," with bigoted Archie arguing with his liberal son-in-law Mike.

Another plan for the new season is more prominence for the character of Gloria, Archie's daughter, played by Sally Struthers.

"It's been easy to underwrite her, to let her serve as a feeder of lines," Rich said in an interview. "We want to use her enormous talent."

"We received letters from a women's lib group asking 'What does she do? What's her job, her education? Is she just around all the time?'"

"Norman Lear—producer—showed me a letter signed by about 50 women in bold signatures and said, 'What do you think?' I said, 'I have to agree. We have somewhat ignored Gloria. I think we should write stories that give her another function than being another ear on the set.'"

So Gloria will have a job, maybe part time to start with. "What's happening in the job market will tell us," Rich explained.

The show tries to stick to reality, he said. "We tell our writers, 'Don't write funny. Write real; it'll get funny. The characters will dictate the fun.'"

"Family" won the TV Academy's Emmy as outstanding comedy series of last season. It took a writing award, and Miss Struthers tied with Valerie Harper of "The Mary Tyler Moore Show," both receiving Emmys as supporting comedienne.

Carroll O'Connor, as Archie, and Jean Stapleton, as his wife, were named outstanding comedy series stars. And Rich won for his direction of an epis which had Sammy Davis Jr. as a guest star.

Young Woman's Body Unclaimed

CHICAGO (AP) — She is known to authorities only as Case No. 170.

Her body has been in the Cook County Morgue since May 18, but there have been no inquiries about her to either the morgue or the police, authorities said Wednesday.

The woman was found unconscious in a Greyhound bus that arrived from Minneapolis at 2 a.m. May 18. She never regained consciousness, and died later in the day of still-undetermined cause, police said.

Her only possessions were her clothes: a white blouse, blue slacks, brown loafers and a yellow coat.

She was 5 foot 2, weighed 118 pounds and had brown hair and hazel eyes. Authorities estimate she was between 18 and 22 years old.

"Somebody, somewhere must know who she is," said Chief Deputy Coroner Kyran Phelan.

Railroad Diner Serving Again

CHICAGO (AP) — Chicagoans now can have the fun of eating on a plush railroad diner without going anyplace.

The Rock Island Lines has installed a diner and club car from the old Golden State Limited on Track 1 of La Salle Street Station and opened them as a restaurant serving luncheon and dinner.

In conjunction with the Southern Pacific, the Rock Island operated the Golden State Limited between Chicago and Los Angeles until declining patronage forced its discontinuance.

criticism was heard last season that "Family" had lost the racial zing that helped boost it to the top of the ratings.

Rich replies: "If you stayed on racial themes every week, then it would be boring. Even a racist doesn't talk race all day long."

O'Connor said in a separate interview: "I think people are perhaps getting used to what we're doing so the original surprise is somewhat gone out of the show. But CBS is not mellowing Archie.

"We have to keep Archie true, but we're not going to have him yell 'coon' every week just so we can keep up the reputation of being a racially pungent show."

Buckeyes Thrift
CINCINNATI (UPI)—Hamilton County, Ohio, has the largest number of savings and loan institutions of any county in the United States. The county, which includes Greater Cincinnati, has 160 savings and loan offices, compared with 35 in Cuyahoga County (Cleveland), the largest county in Ohio.

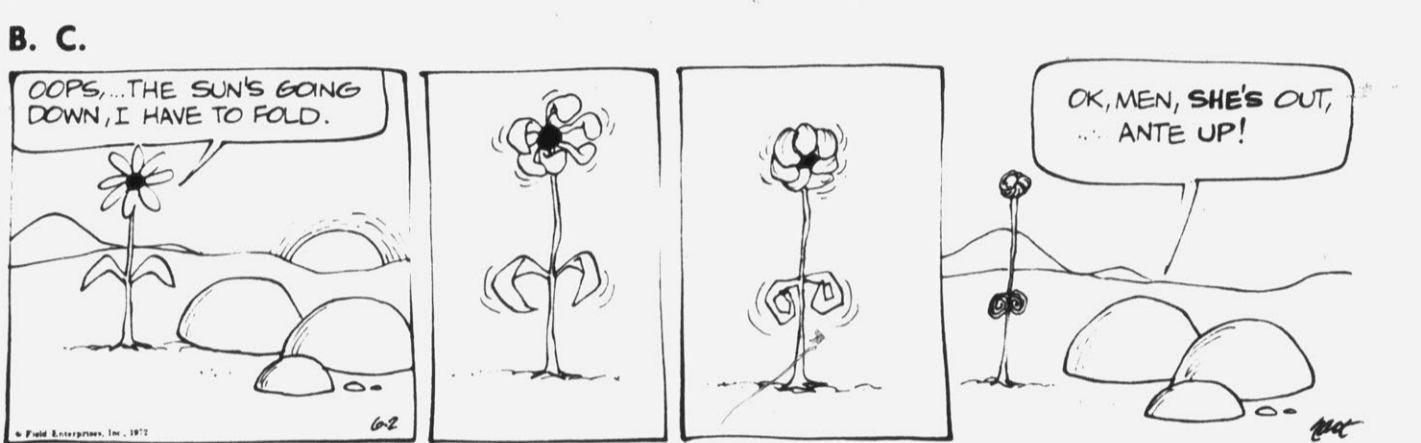

The Dodge Boys Think About You. You can depend on it!



WHEN YOU BUY A CAR FROM BRIGHT LEAF MOTORS

BILLY JOHNSON IS YOUR MAN.

1. He works for you.
 2. He's your best form of consumer protection.
 3. When you buy from him, you get...
- He may be in business for himself. But unless he pleases you and continues to satisfy you, he isn't going to stay in business. It's that simple.
- No amount of legislation is going to replace that personal relationship between you and the man you deal with. So when you talk, he listens. And locks himself into the sale to keep you satisfied.
- ... a promise that he'll try his darndest to live up to the tradition of "Dodge dependability" with prompt service. For one sound reason. He wants you to buy another Dodge from him.

He can also offer you a Dart Swinger with a free automatic transmission!

The Dodge Boys can offer you the automatic transmission FREE OF CHARGE (because Dodge doesn't charge them for it) when you buy a specially equipped 1972 Dodge Dart Swinger or Dart Custom four-door sedan with: automatic transmission (free in the Specials), power steering, Light Package, AM radio, vinyl roof, white sidewall tires, variable-speed wipers and electric washers, bumper guards, left remote-control mirror, body side moulding with vinyl insert, rear deck lid lower moulding, undercoating and hood pad, and deluxe wheel covers.



Dodge CHRYSLER CORPORATION
AUTHORIZED DEALERS
BRIGHT LEAF MOTORS, Inc.
3012 S. Memorial Drive
Greenville, N.C.

DEPEND ON THE DODGE BOYS

The Worry Clinic Aftermath Of A Vasectomy

Ned has joined 1,000,000 other husbands who have submitted to a vasectomy operation to prevent further pregnancy of their wives. But now his 2nd wife wants babies! Note the possible medical solutions to her problem.

By GEORGE W. CRANE, Ph.D., M.D.
Case T-593: Ned P., aged 36, is in a dilemma.
"Dr. Crane," he began, "I recently married for the second time."
"My first wife was a won-

derful girl and we had 4 children. "Then she decided that was an ample family so she urged me to submit to a vasectomy, which I did.
"But after 12 years of happy marriage, she was killed in an auto accident.
"Our oldest child was only 10 at that time and we were all heartbroken.

"But we finally got somewhat adjusted, for I hired an elderly woman to serve as housekeeper. "A year ago I met one of the school teachers of my children and we eventually fell in love. "Now we are married and quite happy, except for the fact she wishes she could have a couple of children of her own. "But I am now sterile because

of my vasectomy so what could be done to fulfill her wish for babies of her own?"
Vasectomy Operation
It is estimated that one million American husbands have already had vasectomy operations.
This is a simple, inexpensive surgical procedure, often performed in the physician's office under local anesthesia.
It involves tying off the tubes that carry the sperm cells from the testicles.
Sometimes it is possible to reunite the severed ends of those tubes so they can function again.
In which case, a husband like Ned may occasionally be able to procreate children.
But the chance of such a successful reopening of the tubes is not very great, though modern techniques are being developed to increase the likelihood of this restorative operation.
A second method that sometimes proves effective is to use a hypodermic needle and syringe for withdrawing some

sperm cells from the male gonads.
These are then ejected upon the cervix (neck) of the wife's uterus (womb) during her "pregnancy week."



In fact, this same method is often employed for artificial insemination of wives, either by their own husbands or by an acceptable male donor.
In Ned's case, the simpler solution would be to start with the second method outlined above.
If it fails, then he could try to have the former vasectomy repaired in the hope one or both

The Daily Reflector, Greenville, N.C.—Friday, June 2, 1972—21
tubes might again function normally.
If neither of those methods proves successful, then his new wife should concentrate on being a devoted mother to her 4 stepchildren.
For the true parent-child relationship does not depend on blood kinship whatsoever, but is based on mutual respect, admiration and "earned" love.
An adopted child may thus be as devoted as any flesh-and-blood offspring.
And a blood brother may slay his sibling, as Cain murdered Abel.
Send for my medical booklet "Facts About Pregnancy," enclosing a long stamped return envelope, plus 25 cents.
(Always write to Dr. Crane in care of this newspaper, enclosing a long stamped, addressed envelope and 25 cents to cover typing and printing costs when you send for one of his booklets.)
Cuts in the eye area should be bandaged lightly with a sterile gauze patch, then professional treatment sought.

Cold Compress For Black Eye

NEW YORK (UPI)—You hear about the beefsteak treatment for a "black eye." But the Society for Visual Care makes this suggestion. Treat the area where a blow has been struck with cold compresses applied for 15 minutes an hour over a period of hours until relief becomes apparent. Since a black eye can mean serious internal damage to the eyeball, an eye care specialist should be seen.

The Greening of Pennsylvania
PITTSBURGH (UPI) — The Pennsylvania Game Commission has provided more than 5.6 million seedlings this spring to help keep Pennsylvania green. More than half were planted on state game lands, farm-game projects and private land kept open to the public for hunting purposes.

FORECAST FOR SATURDAY, JUNE 3, 1972



CARROLL RIGHTER'S HOROSCOPE

from the Carroll Righter Institute

GENERAL TENDENCIES: Be careful that temper does not take possession of you when you are thwarted in a particular aim that is important to you. Keep a smile ever present and avoid becoming embroiled in an argument that could cause trouble later on.

ARIES (Mar. 21 to Apr. 19) You can complete arrangements you started with allies but don't let worry get you down. Try to assist one who is in trouble. Also, you can now handle a personal problem.

TAURUS (Apr. 20 to May 20) You are able to handle well a career matter in the morning. Later you can join an associate in a group affair. Stop procrastinating in the payment of an important bill.

GEMINI (May 21 to June 21) Stick to the important work at hand instead of going off on a tangent and then you gain the respect of a bigwig. Make plans for the future while attending to routine tasks.

MOON CHILDREN (June 22 to July 21) Take care of important responsibilities during the morning and you will have time to join friends later on. Plan a trip to some new place. Count the cost well.

LEO (July 22 to Aug. 21) Morning is the best time to get the approval of family and friends. Be sure to keep promises made to others. Use your intuition now for best results. Get rid of your fears.

VIRGO (Aug. 22 to Sept. 22) Take care of regular routines in the morning so you can go out later with friends for entertainment. Reconciling with one who means much to you is important. Be wise.

LIBRA (Sept. 23 to Oct. 22) Visit good friends today, and then get busy tonight with work that must be done. Try to meet the expectations of others. Make plans for a party in your home in the near future.

SCORPIO (Oct. 23 to Nov. 21) Handle daily affairs early in the day so you have time for happiness with friends later. Put those creative talents across. Show others that you are a charming person.

SAGITTARIUS (Nov. 22 to Dec. 21) Use good judgment in planning the future in the morning. Then, improve home conditions with the cooperation of kin. Don't forget to shop for whatever is needed. Be wise.

CAPRICORN (Dec. 22 to Jan. 20) Study monetary position well in the morning and then you can indulge in hobbies that mean much to you. Enjoy company of congenials. Study new ways to be more productive.

AQUARIUS (Jan. 21 to Feb. 19) Take treatments that improve your health and then make plans for a more prosperous future. Make contacts that open up new vistas for you. Show that you are capable.

PISCES (Feb. 20 to Mar. 20) Find better ways of doing chores in the morning. Later you can attend a social event you enjoy. Show that you are a practical person and gain the respect of others.

IF YOUR CHILD IS BORN TODAY... he or she will be one of those young people who early in life likes to spend much time with others, but later will change to a quiet, hard working individual seeking success. Cultural attainment will become very important to your youngster in the years ahead. Give as fine an education as you can afford, stressing philosophy.

"The Stars impel, they do not compel." What you make of your life is largely up to YOU!

Carroll Righter's Individual Forecast for your sign for June is now ready. For your copy send your birthdate and \$1 to Carroll Righter Forecast (name of newspaper), Box 629, Hollywood, Calif. 90028

(© 1972, McNaught Syndicate, Inc.)

TV Log

Boom In Baby Food Continuing

NEW YORK (UPI)—A boom in baby food is continuing at a record rate, according to an industry official.

In 1930, when the baby food industry was born, the annual consumption per baby in the United States was about six jars, says John C. Suerth, chairman of Gerber Products Co. Now the annual average per capita consumption of baby foods is 62 dozen jars. This includes vegetables, fruits, meats, vegetable and meat combinations and cereals.

The Chinese Wall was built by hand by hundreds of thousands of slaves and prisoners.

WNCT — Ch. 9

FRIDAY
7:00 Truth or 11:26 In The News
7:30 Dick Van Dyke 11:30 Josie
8:00 O'Hara 11:56 In The News
9:00 Movie 12:00 The Monkees
10:30 Don Rickles 12:30 Film Festival
11:00 Final Report 2:00 Movie
11:30 Movie 4:00 Arthur Smith
12:00 Movie 4:30 Playback
5:00 Belmont
SATURDAY
8:00 Bugs Bunny Stakes
8:30 Scooby Doo 6:00 Porter
8:56 In The News 6:30 News CBS
9:00 Globetrotters 7:00 Hee Haw
9:30 Hair Bear 7:00 Hee Haw
9:56 In The News 8:00 In The Family
10:00 People 8:30 Name of Game
10:26 In The News 10:00 Impossible
10:30 Archie 11:30 Roller Derby
10:56 In The News 12:30 Movie
11:00 Sabrina

WITN — Ch. 7

FRIDAY
7:00 Jeannie 10:00 Jetsons
7:30 Nashville 10:30 Barrier Reef
8:00 Sanford and 12:00 Mr. Wizard
8:30 Movie 12:30 Bugatoon
10:30 Dragnet 1:00 Bill Anderson
11:00 News Wheel 1:30 Once Upon a
11:30 Tonight Show 2:00 Kemper Open
1:00 News 3:00 Baseball
SATURDAY
7:00 The Fence 6:00 News
7:30 Treeshow 6:30 NBC News
8:00 Dr. Dolittle 8:00 Emergency
8:30 Deputy Dawg 9:00 Movie
9:00 Woodpecker 11:00 News
9:30 Pink Panther 11:30 Movie

WCTI — Ch. 12

FRIDAY
7:00 Gilligan 11:00 Curiosity Shop
7:30 Jimmy Hart 12:00 Jonny Quest
8:00 Brady Bunch 12:30 Lancelot Link
8:30 Partridge Fam stand
9:00 Room 222 2:00 Western
9:30 Odd Couple 5:00 Wide World
11:00 Love Amer 6:30 Rod Reel
Style 7:00 Jim and Jesse
11:00 News 7:30 Batman
11:30 Dick Cavett 8:00 Bewitched
SATURDAY
7:00 Yogi and Huck 8:30 Election
7:15 Teletory 6:30 NBC News
7:30 Chico Kid 9:30 Showtime
8:00 Jerry Lewis 10:30 Election
8:30 Road Runner 11:00 ABC News
9:00 Punky 11:15 Election
9:30 Jackson Five 11:45 Wrestling
10:00 Bewitched 12:45 Theatre

HI-WAY 264 PLAYHOUSE THEATRE
4 Miles West of Greenville on 264
Phone 756-0846

SATURDAY AFTERNOON ONLY!
Shows at 1, 2:30, & 4:00 RATED "G"

"Dead Man's Gold"
STARRING
Lash La Rue
All Time Great Movies From The Past.

NOW SHOWING
COLOR RATED X
"Adult Entertainment Center"

SHOW TIME DAILY
MON-SAT. SUNDAY
6:00 2:00 6:00
7:20 3:20 7:20
8:40 4:40 8:40

CROSSWORD PUZZLE

ACROSS
1. Sentence
4. Paddle
7. At a distance
11. Pepper plant
12. Back
13. Baseball team
14. Calm
15. Geraint's wife
17. Sketch
18. Elanet
20. Prior
22. Rough
25. A-one
28. Sarlak
30. Procutee
31. Trouble

DOWN
32. Wise
33. Purpose
34. Town square
36. Wood sorrel
38. Sweet potatoes
40. Positive electrode
44. Formerly
45. Teamster
48. Stag
49. Three-toed sloths
50. Duster
51. Different
52. Hymenoptera
53. Fuss

21. Watch carefully
23. Play on words
24. However
25. Drumbeat
26. Salad ingredient
27. Cast
29. Servicemen's address
32. Poor actor
35. Judge's bench
35. Smoke tree wood
37. Reason
39. Attempt
41. Soup ingredient
42. Defunct
43. Therefore
44. Article
45. Princely nickname

Par time 28 min. AP Newsfeatures 6-2 47. Meadow grass

MATS ORC GIN
AGHA LOO ETE
RIOT ADVERSE
TORUS SERA
ROE TRIBE
SWINDLE NAN
EON FOURTHS
TESTS SSE
IOTA OVERT
IMPORTS ARIA
LEI AUK MINK
AND PAY PAGE

SOLUTION OF YESTERDAY'S PUZZLE

DOWN
1. Absorbed
2. Sandarac tree
3. Spotted cavy
4. Prose
5. Uris
6. Modern music

7. Foreign news agency
8. Subtly
9. Cuckoo
10. Tritan
15. Sherbets
19. Exasperate

GOREN ON BRIDGE

BY CHARLES H. GOREN
(© 1972, By The Chicago Tribune)
Neither vulnerable. North deals.

NORTH
▲ A 7
○ K 8 5 3
○ A K 10 2
▲ 9 7 3

WEST
▲ Q 10 8 6
○ 10
○ 8 7 6
▲ Q J 10 6 2

EAST
▲ 9 5 4 2
○ A 2
○ J 4 3
▲ K 8 5 4

SOUTH
▲ K J 3
○ Q J 9 7 6 4
○ Q 9 5
▲ A

The bidding:
North East South West
1 NT Pass 3 Pass
4 Pass 4 Pass
4 Pass 5 Pass
5 Pass 6 Pass
6 Pass Pass Pass

This week, we have been presenting hands featuring the Precision Club System of bidding which scored such outstanding triumphs at the Spring Nationals recently concluded in Cincinnati. Our previous examples were taken from the Vanderbilt Team Event. Today's hand is from the Open Pairs which resulted in a tie for first place between Barry Crane, Los Angeles and Dr. John Fisher, Dallas, who had won the event in both of the previous years and two youngsters — Matthew Granovetter, Jersey City, N. J., and Merle Tom, New York City, who were playing Precision.

In the above hand Granovetter and Tom were one of only two pairs in their section to reach six hearts. One of the basic ingredients of Precision is that all strong hands (16 high card points and up) should be opened with an artificial bid of one club. A by-product of this technique is that the opening one no trump range is reduced to 13-15 points, which accounts for North's opening slam. The jump to three hearts is game forcing and in the particular methods employed by the winners designated an interest in slam.

Had North intended to settle for game, he would have merely proceeded to four hearts. The four diamond call is a cue bid, showing first round control of diamonds, implying a heart fit and therefore, designating an interest in getting to a slam. Altho South merely tempo-rized with a rebid of four hearts, holding several key controls himself, North gave his partner another chance by cue bidding the ace of spades.

The remaining calls were natural. South showed the ace of clubs, North the king of diamonds, and South the queen. North had now shot his bolt and when he merely returned to six hearts, the auction subsided. The defense had to content themselves with the ace of trumps as their only trick on the deal.

PITT
505 EVANS STREET

Academy Awards Goofed!
Public Proved Them All Wrong
The Best Motion Picture of 1971 was... BILLY JACK!

Rex Reed said it best, "I was expecting nothing, and discovered something memorable." Jim Schertzer in Winston-Salem said "I must confess I liked it more the second time."
People came back two, three, four times to see Billy, one girl in Minneapolis saw it NINE TIMES! It was an absolute sensation, particularly in the South.

BILLY JACK Was Seen By More People Than All The Other 'Best Picture' Nominees!

Proof that BILLY JACK is "Best." More people saw Billy than the combined audiences of the 5 Academy Nominees, "Last Picture Show," "Clockwork," "Fiddler," "Nicholas" and "French Connection." Doesn't that tell you something.

36 Weeks..... CHARLOTTE!
38 Weeks..... NORFOLK!
34 Weeks..... GREENSBORO!
32 Weeks..... COLUMBIA!
42 Weeks..... ATLANTA!
33 Weeks..... RALEIGH

RETURN TRIBUTE — JUNE 2nd
The Best Motion Picture of 1971!
BILLY JACK*
TOM LAUGHLIN • DELORES TAYLOR
Starts Today!
2:25 - 4:45 - 6:45 - 9:00
CHEER FOR BILLY — AT LEAST ONE MORE TIME!

Whipple the BIRTH

1. IF YOU TAKE THE FIRST PARKING SPACE YOU COME TO, YOU'LL WALK PAST ANOTHER THAT'S CLOSER...
2. BUT PASS IT UP, AND THERE WON'T BE ANOTHER AROUND THE ENTIRE BLOCK...
3. AND BY THEN YOUR FIRST SPOT WILL BE TAKEN...
4. SO YOU'LL PARK TWO BLOCKS AWAY...
5. AND AFTER WALKING BACK THERE'LL BE TWO EMPTY SPACES RIGHT IN FRONT OF THE STORE!

Thanks to JOHN CRESEMAN BETHLEHEM, PA.
CRESEMAN'S LAW: "RUSSIAN ROULETTE WAS INVENTED BY AN AMERICAN AUTOMOBILE!"

PARIK
THE FIRST IN OUR "FRONTIER DAYS" SERIES!
SEE THE ALL-TIME GREATEST WESTERN STARS
IN 2 OF THEIR ACTION FILL HITS

GENE AUTRY — **Lash LA RUE**
NO QUARTER ASKED OR GIVEN
THE FIGHT OF YOUR LIFETIME
WITH DEADLY BULLWHIPS.

KING OF THE BULLWHIP
LASH LA RUE FUZZY ST JOHN
JACK HOLY • TOM NEAL ANNE GUYWINE

GENE AUTRY RIDES AT
1:00 - 3:50 - 6:40 - 9:30
LASH LA RUE LASHES OUT AT
2:35 - 5:25 - 8:15
Complete Shows at 1:00 - 2:30 - 5:20 - 8:10

"THE LAST ROUNDUP" TODAY & SATURDAY! RATED (G)
752-7649 • DOWNTOWN GREENVILLE
STARTS SUNDAY! JAMES COBURN IN "THE CAREY TREATMENT"

PLAZA CINEMA
756-0088 • PITT-PLAZA SHOPPING CENTER
HURRY! LAST 5 DAYS! ENDS TUESDAY!

PARAMOUNT PICTURES PRESENTS
The Godfather

Albert S. Ruddy PRODUCTION
STARRING Marlon Brando
AND Al Pacino James Caan Richard Castellano Robert Duvall Sterling Hayden John Marley Richard Conte Diane Keaton

PRODUCED BY ALBERT S. RUDDY
WRITTEN BY FRANCIS FORD COPPOLA
BASED ON THE NOVEL BY MARIO PUZO
DIRECTED BY FRANCIS FORD COPPOLA
MUSIC BY NINO ROTA
COLOR BY TECHNICOLOR
A Paramount Picture

SHOWS DAILY AT 1:45-4:45-8:00
ACRES OF FREE PARKING
WED.! Charles Bronson-Jack Palance "Chato's Land"

MEADOWBROOK
ENDS TONIGHT

Come see how the vampires do it.

Metro-Goldwyn-Mayer
A Dan Curtis Production
House of Dark Shadows
Metracolor MGM

Night of Dark Shadows
METROCOLOR GP

SATURDAY ONLY
Vincent PRICE..

Of the Banshee
A Dan Curtis Production

WILD BIKES VS DUNE BUGGIES!
WILD WHEELS
COLOR

TICE DRIVE-IN THEATRE
FRI. - SAT.

BURT LANCASTER
ROBERT RYAN
LEE J. COBB
in A MICHAEL WINNER Film
"LAWMAN"
COLOR BY DeLuxe
United Artists GP

Lola
loves it

and so will YOU!
She's almost 16.
He's almost 40.
It's the funniest affair that ever jumped the generation gap.

TECHNICOLOR® GP
AMERICAN INTERNATIONAL RELEASE

Japan Plays Increasingly Important Role In Japan

By DANIEL DROSDOFF
RIO DE JANEIRO (UPI)—Masao Kiyono, 50, never asked for or got a loan from a bank or anyone else to buy his small grape farm in Ibiuna, some 50 miles from Sao Paulo.

"I do not like to borrow because I do not like to pay interest," he said.

Kiyono came to Brazil as a child in 1935 from Hokkaido with three brothers and a sister to work on coffee plantations. "We suffered much. We were treated like slaves," he recalled unhappily.

But, by long hours of work and frugal saving, Kiyono and his wife got the money to buy a small farm that now produces 33,000 pounds of Italian grapes a year. Neighbors marvel because, while the harvest of most grape growers in the region lasts only one month—February — Kiyono's harvest lasts from February to March.

Because of the high crop yields achieved by farmers such as Kiyono, the Japanese in Brazil are known as "agricultural wizards." But Kiyono said there was no secret to his success.

"I built an artificial lake near the vineyard. This keeps the temperature even all year round," he said.

Future Impact

The efforts and skill of Kiyono are an example of how the Japanese have made their influence felt, not only in Brazil, but in Latin America as a whole. Prospects are the Japanese will make an even greater impact in the future, not so much in immigration as in the field of investments from

the mother country.

In Peru, Japanese investment nearly double when Petro-Peru signed a contract with the Toyo Engineering Co. of Japan for a \$44 million fertilizer plant in Talara, near the border with Ecuador.

In Argentina, the government is negotiating with Japan for a contract totaling \$400 million for renovation of the General Roca Railroad which spreads a web to southern Argentina.

Japanese investments in Brazil are estimated at somewhere between \$600 million and \$1.17 billion, with the corporations of Mitsubishi, Seiko, Hitachi, Toshiba and, Mitsui holding much of it. The Ishikawajima shipyards have built 200,000 dead weight tons, and Toyota, which has had a tiny factory here for 17 years, is planning to expand operations to compete with Volkswagen, which has captured 65 per cent of the Brazilian market.

Economy Minister Antonio Delfim Neto visited Japan recently and suggested that there was plenty of room for more Japanese investment, especially in joint ventures.

persons, while Chile's numbers less than 1,000, according to Japanese embassy estimates.

But the impact of the Japanese cannot be judged in terms of numbers alone. Individual talent goes far.

Take the case of Jorge Enrique Hoshino, a civil engineer and a horticulture technician who arrived in Bogota, Colombia, in 1921, representing a Tokyo construction firm.

He is the first Japanese known to have settled in Columbia. Hoshino, now 73, has designed parks and gardens all over the country, including those of the National University. At the request of then Venezuelan President Romulo Betancourt, he designed and built a floating garden on the terrace of the Miraflores Palace in Caracas.

The Japanese community in Brazil has its base in the immigration of workers to the coffee plantations in Sao Paulo State that began in the first decade of this century.

A Success Story

Yoshihiko Maeda, 62, came to Brazil at the age of 18 to work on a potato farm on a subsistence salary.

Aided by his four daughters and three sons, Maeda now owns a 173-acre farm that produces 3,000 chickens a month and brings in an annual harvest of 1,500 sacks of potatoes, 2,000 boxes of grapes, and 8,000 boxes of carrots and artichokes.

On the side he produces apples and plums.

"We have no special technique," Maeda said. "We follow the instructions of a Japanese agronomist who orients us. I do not know what methods he follows. We read a lot of books, and most are in Japanese."

The monument to Japanese agricultural influence in Brazil is the giant CEASA cooperative market in the city of Sao Paulo. Here 60 per cent of the fruits and vegetables and fish for the city are bought and sold, and some 80 per cent of the dealers are Japanese. Their products

also are trucked north to Rio de Janeiro where they stock the fruit and vegetable markets.

Pervasive Influence

Nowadays the Japanese influence in Brazil makes itself felt just as much in the city as in the countryside.

The mayor of the town of Cotia, with 30,000 inhabitants, one-third of them Japanese, is 36-year-old Kenji Kira, the son of a Japanese coffee plantation worker who later came to own his own farm.

One of the most voted for politicians of Sao Paulo State is Diogo Nomura, who sits in the Federal Chamber of Deputies in Brasilia. Five of the deputies in the Sao Paulo State legislature also are of Japanese descent.

In downtown Sao Paulo Japanese police and salesgirls are a common sight.

In the Sao Paulo universities, 10 per cent of the students are Japanese, while only 5 per cent of the city population is Japanese. The city has two Japanese language newspapers,

three Japanese movie theaters, two Japanese welfare centers, 35 Japanese restaurants, and six Buddhist temples with a membership of about 10,000 persons.

Links with the old country are common.

The highest ranking officer of Japanese descent in the state military police, Capt. Reizo Nishi, studied planning and radio patrolcar tactics in Tokyo.

Massami Uyeda, one of the seven Japanese public prosecutors in Sao Paulo, traveled to Japan to take a special course in drug prevention.

Once a year experts and judges of Kendo, the swordplay that dates from the times of the Samurai, fly from Japan to Sao Paulo to supervise competition and awards at the all-Japanese Piratininga club.

Discrimination Minor

Discrimination against the Japanese exists but has not become a major problem. Some governments, Brazil and Argentina among them, have encour-

aged Japanese immigration to boost agriculture in frontier and poorly developed regions, for instance northern Misiones province in Argentina, and the Amazon basin in Brazil.

The Venezuelan government, on the other hand, has discouraged projects for settling Japanese farm workers.

Mitigating widescale discrimination is the fact that most Latin American countries, and especially Brazil, are multi-

racial in makeup. This tends to allow for a melting into the population, if not necessarily full acceptance.

In Argentina there have been complaints against the Japanese as "very closed" although their business sense and industry are admired. In Brazil, despite their numbers and the nation's polyglot racial mix, few Japanese have gotten into the higher echelons of government or the military.

Have You Missed Your Daily Reflector?

First Call Your Independent Carrier. If You Are Unable To Reach Him Call The Daily Reflector, 752-6166 Between 6:00 And 6:30 P.M. Weekdays And 8 'Til 9 A.M. On Sundays.

Brazil's Japanese

Brazil not only takes the lion share of Japanese investment in South America, but it also has the largest Japanese community, estimated at about 750,000 persons. This is over 10 times the size of the Japanese community of Peru, estimated at 70,000 persons.

Brazil's is believed to be the largest Japanese community outside of Japan. Argentina's Japanese community numbers 20,000, while Mexico's is estimated at 4,000. Colombia and Venezuela have Japanese communities estimated at only 1,000

Still No. 1 At Berkeley PTI Courses Are Rotated

BERKELEY (UPI)—Correspondence courses have been a big educational thing for many years they are still number one at the University of California Extension in Berkeley.

In 1971, 16,000 students in 78 countries and all 50 states in this country were enrolled. Almost anybody can take courses and the student body is made up of persons from a variety of backgrounds.

Alice Rowbotham, director of the program, said: "We have many servicemen overseas, people in remote areas, prisoners, and handicapped students."

Also enrolled are college graduates and teachers taking refresher courses in their field.

"It takes a high degree of motivation on the part of the students," said Mrs. Rowbotham. "You need tremendous self-discipline."

Robert Lee Nye, being held in the San Quentin Death Row for the stabbing death of an Arcadia housewife, is a good example.

In 1971 he earned an "A" in astronomy and now is taking analytic geometry and calculus as well as freshman reading and composition.

Pitt Technical Institute is continuing to offer courses on a rotating schedule in order that law enforcement officers might earn their associate in applied science degree.

Courses to be taught during the summer quarter are math for applied science, Monday-Friday, 9 to 10 a.m.; and crime and delinquency, Monday-Friday, 10-11 a.m.

The same courses will also be taught at night; math for applied science on Tuesday and Thursday, 7-9:30 p.m. and crime and delinquency on Monday and Wednesday, 7-9:30 p.m.

Registration will be held Monday, from 9 a.m. to 3 p.m. Officers working day shifts may register Tuesday, from 7-8:30 p.m.

In-service law enforcement personnel are eligible for grants to cover the cost of tuition and books.

For further information about the program, interested persons should contact the Director of Student Personnel of Lloyd Huggins, Pitt Technical Institute, P.O. Box 7007, Greenville, N. C. Phone: 756-3130.

TAKE A SUMMER VACATION ALL YEAR

STOP BEING THE DISHWASHER.

Buy A New KitchenAid

Made By Hobart Mfg. Company, The World's Oldest And Largest Maker Of Commercial Dishwashers.

BUCK SUPPLY CO.
201 Grande Ave. Greenville, N.C.
Phone 758-3191

VISIT OUR SHOWROOM TODAY!



The newest KitchenAid dishwashers are built better than ever before. For even greater reliability. The new KitchenAid 1/2 hp motor — the most powerful in any home dishwasher — now has a 5 year warranty*. Many other reasons to buy KitchenAid too: Patented Soak Cycle. 180° Sani-Cycle. Adjustable racks. Choice of dishwasher types.

*If the motor should fail, it would be replaced at no cost to you during the first year; you'd pay only for labor during the next four years.



SKIPPER BOWLES CARRIED TWICE AS MANY COUNTIES IN NORTH CAROLINA

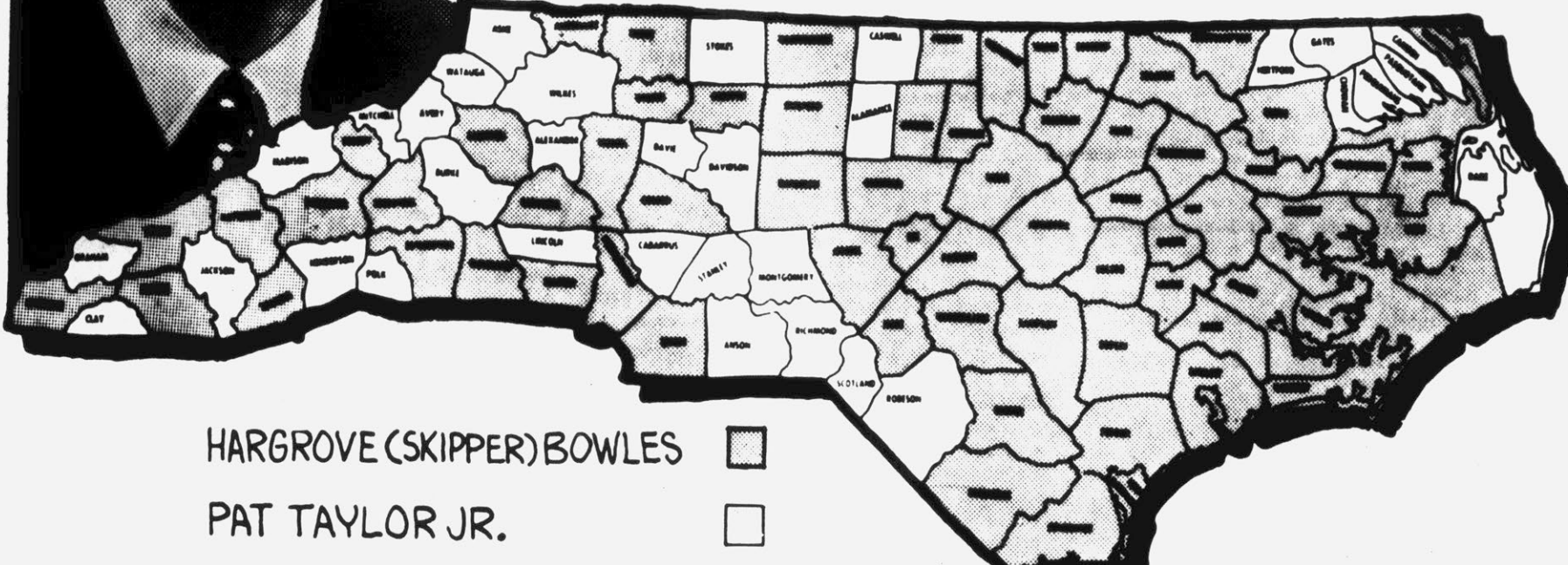

HARGROVE (SKIPPER) BOWLES

PAT TAYLOR JR.

THIS MANY CONCERNED NORTH CAROLINIANS CAN NOT BE WRONG.

NOW ...

LET'S GIVE SKIPPER BOWLES TWICE AS MANY VOTES IN THE SECOND PRIMARY ON SATURDAY, JUNE 3rd!

Paid For By Committee For Bowles For Governor

Greene Central Wins To Even Series

CONCORD — Greene Central vice spotted Northwest Cabarrus a one-run lead, but bounced back each time and gained a 5-2 victory over them to tie the best-of-three series at a game each in the finals of the State 3-A Baseball Playoffs.

The two will now meet in the final game on the series, to be played Saturday at 3 p.m. at Concord. Greene Central dropped the first game of the series, 4-0, on Wednesday night. Northwest proved to be a

tough opponent to dispose of in the second game, as they tried to finish the series in two games and take the title themselves. But the Rams were having no part of that as they got back into the action and made things all

even. It was a scoreless deadlock until the third inning, when Northwest finally broke the ice. Dennie McNulty led off with a single and Russ Hartsell

followed with a hit, driving him to third. A wild pitch then brought in McNulty for a 1-0 Cabarrus lead.

The Rams came right back to tie it up, however, in the bottom of the third. Donnie Taylor singled and Elwood Grant moved him to second with another hit. Pitcher Gary Marshall tried for a pickoff play at second, but threw the ball away, and Taylor trotted on to third. Mike Perry then hit into a fielder's choice that scored Taylor with the tying run. The Rams went on to load the bases, but failed to score again.

Then, Northwest tried for a squeeze, but the Rams had it spotted and had a pitchout called. The ball was dropped on the tag, however, letting Winecoff score, making it 2-1. Greene Central then put it together in the fourth inning to forge ahead and take the lead for good. Billy Williamson led off with a single and Danny Whitley sacrificed him to second. Taylor reached on an error and Grant singled, driving in Williamson. Both Taylor and Grant moved up on another error on the reay. Richard Holloman walked and Robert Ivey did too, forcing in Taylor with the second run. Perry got a walk, scoring Grant and Stevie Williamson hit into a fielder's choice, scoring Holloman, leaving the bases still loaded. Northwest shored up its defense, however, and stopped the Rams there.

Northwest tried twice more to get something going. They put two on in the fifth on a walk and an error, and two more in the seventh with two away, when Williamson walked two. The Rams, however, stopped each of these threats without damage. Greene Central also offered a couple of other threats. In the fifth, Whitley and Grant each singled, but failed to score. Perry led off the sixth with the game's only extra-base hit, a double, and was wild pitched to third, only to wait out the inning there.

Scoreboard table with columns for team, AB, R, H, RBI, and totals for Greene Central and Northwest.

Siebert Throttles Baltimore; Perry Hurls His Ninth Victory

By HERSCHEL NISSENSON Associated Press Sports Writer Sonny Siebert isn't much on third-watching, but nothing lifts his spirits like the sight of the Baltimore Orioles.

California and Texas were not scheduled. National League scores: New York Mets 6, Philadelphia 1; Chicago Cubs 7, St. Louis 3; San Francisco 5, Los Angeles 2; Cincinnati 10, Houston 3; Pittsburgh, Montreal, Atlanta and San Diego had the day off.

Rico Petrocelli staked Siebert to a 2-0 lead in the first inning with a two-run single off Dave McNally and Carlton Fisk slammed a two-run homer in the second, his third in the last four games.

Cleveland got Perry the only run he needed against Detroit in the third inning when Eddie Leon walked, Perry sacrificed and Tom McCraw singled, one of only three hits off loser Joe Coleman.

The Tigers nipped Perry for seven hits, two each in the first and fifth, but the tall right-hander worked out of each threat and ended the Indians' seven-game losing streak. Their last victory was on May 23—a shutout by Perry, natch.

Richie Scheinblum tremendous 471-foot pinch two-run homer in the eighth inning off Dave LaRoche lifted the Royals over the Twins and enabled them to snap a five-game losing streak.

Eric Soderholm homered as Minnesota took an early 3-0 lead but the Royals caught up in the sixth when Steve Hovley singled.

Chicod In 8-4 Win

Chicod rolled to an 8-4 victory over the Hornets in the Southern Pitt Little League yesterday.

Siebert took a so-so 3-2 record and bloated 4.47 earned run average into the game but throttled the Birds on seven hits and one unearned run and reduced his ERA to 3.82.

Cleveland got Perry the only run he needed against Detroit in the third inning when Eddie Leon walked, Perry sacrificed and Tom McCraw singled, one of only three hits off loser Joe Coleman.

Pepsi-Cola moved into sole possession of first place in the Tar Heel Little League yesterday with a 17-3 victory over the Exchange.

Pepsi is now 4-1 in the league, while the Exchange fell off to 2-4. Pepsi pushed into the lead in the first inning, scoring a run.

The loss was the first for Taff, now 3-1 in the league. It was the first win in three starts for the 76ers.

They gained the lead in the first inning, scoring once. Wayne Bailey led off with a single and Steve Fuchs got a hit to move him to third. Roy Hudson then singled him across, for the lead.

Kevin Adams was the winning pitcher, while Dale Bailey was tagged with the loss.

SAAD'S SHOE SHOP. Prompt Service Work Guaranteed 113 Grande Ave.

"You look at his statistics and they're not that great," said Billy Hunter, a Baltimore coach. "But when he sees the Orioles' uniforms he doesn't worry too much."

Elsewhere, Cleveland nipped Detroit 1-0 as Gaylord Perry became the first nine-game winner in the majors, Kansas City downed Minnesota 5-3 and Milwaukee edged the New York Yankees 9-8 in 12 innings. Oakland, the Chicago White Sox,

passed ball. He took third on an out and scored on another passed ball. Pepsi came up with four more in its half of the third. John Coffman walked, as did Eubanks. Mickey McGrath singled, loading the bases and Avery singled in both Coffman and Eubanks. Worthington singled, and that brought across McGrath and Avery, running the score to 9-1.

The fourth inning saw Pepsi push over seven more runs, including a two-run homer by Shank. They added another in the fifth frame.

The Exchange came up with a run in the fifth inning, and got another in the sixth. John Cleetwood led the Exchange hitting with three, while Hurley had two. Avery had four hits for Pepsi, while Worthington had three and Shank had two.

But it came to a swift end in the seventh. With two outs, Bryan walked for the 76ers on a full count. Then, on the first pitch, Wilkerson cracked a home run, giving the 76ers the victory, 11-9.

Between the ages of 8 and 15, are encouraged to participate. Entry blanks and regulations are available at all Little Mints in Greenville.

SPECIAL THIS WEEK May 29 - June 4

Big Red Machine Rolling Again

By KEN RAPPOPORT Associated Press Sports Writer Break up the Cincinnati Reds and wake up the Houston Astros.

The revitalized "Big Red Machine" continued to roll Thursday night, mashing faltering Houston 10-3 and moving into a second place tie with the Astros in the National League West.

The Little Mint moved further into the lead of the Ladies Softball League last night with a 6-2 win over their nearest rival, Beltone. In the other games, Three Steers won by forfeit over Piggly-Wiggly, and Azalea Mobile Homes took Coca-Cola, 17-9.

Little Mint moved into the lead in the first inning, scoring two runs, as Linda Tripp homered. Beltone came up with one in the third cutting it to 2-1.

But in the bottom of the third, the Little Mint pushed over three runs to put the game away. Winky Phillips singled and Laura Kilpatrick walked. Darlene Briley singled, loading the bases, and Carol Manuel doubled in Phillips and Kilpatrick. Briley was cut down, however. Singles by Dorcas Carter and Pat Kilpatrick brought in Manuel with the fifth Little Mint run.

They added one more in the sixth when Tripp homered again. Beltone picked up its other run in the seventh.

In the other game, Azalea moved ahead in the first inning scoring seven runs. Coke never recovered from that. Becky

BIG BOY COMBINATION PLATE WITH STRAWBERRY PIE. The famous Big Boy hamburger with french fries and Cole Slaw PLUS our famous Strawberry Pie with ripe, red, fresh berries. \$1.59 THIS WEEK ONLY

"It's hard to beat us when we're hitting," Cincinnati Manager Sparky Anderson said in a masterful understatement after his club swept a four-game series at the Astrodome with an awesome power display.

Home runs by Cesar Cedeno and Doug Rader helped Jerry Reuss off to a 3-0 lead as the left-hander struck out seven over the first four innings. Then Cincinnati's "Machine" began hitting on all cylinders.

Steve Stone pitched a five-hitter and rookie Gary Maddox delivered a two-run single in a three-run fourth inning to pace San Francisco's victory. Singles by Tito Fuentes and Ed Goodson started the rally off Bill Singer. Fuentes eventually came home on Chris Speier's sacrifice fly before Maddox drilled his game-winning hit to right.

Rusty Staub drilled a three-run homer in the first inning, giving pitcher Jim McAndrew ample working margin, as New York beat Philadelphia and improved its first-place lead in the East to five games over idle Pittsburgh.

The loss was the 15th in the last 16 games for Philadelphia and plunged the Phillies deeper in the East basement.

Ron Santo, Jim Hickman, and J.C. Martin smashed extra-base hits during a six-run rally in the first inning that powered Chicago past St. Louis. Bill Hands benefited from the outgame to win his fourth game in five decisions.

Standings Senior Babe Ruth League

Wynne's Inc. We have just taken on a new and rather unusual small car. The Subaru

Hal McRae's grand slam home run featured an 11-hit attack that also included homers by Johnny Bench and Tony Perez in the spacious park not especially known as a hitter's paradise. The production gave the Reds a total of 39 runs in the four games.

Steve Stone pitched a five-hitter and rookie Gary Maddox delivered a two-run single in a three-run fourth inning to pace San Francisco's victory. Singles by Tito Fuentes and Ed Goodson started the rally off Bill Singer. Fuentes eventually came home on Chris Speier's sacrifice fly before Maddox drilled his game-winning hit to right.

They added one more in the sixth when Tripp homered again. Beltone picked up its other run in the seventh.

In the other game, Azalea moved ahead in the first inning scoring seven runs. Coke never recovered from that. Becky

Standings Senior Babe Ruth League

Standings Senior Babe Ruth League

Standings Senior Babe Ruth League

Wynne's Inc. We have just taken on a new and rather unusual small car. The Subaru

Johnny has gotten himself started again and Tony's hand is much better," said Anderson, pointing to Bench's four circuit shots in the last three contests and Perez' availability after an injury that knocked him out of 12 games.

They added one more in the sixth when Tripp homered again. Beltone picked up its other run in the seventh.

In the other game, Azalea moved ahead in the first inning scoring seven runs. Coke never recovered from that. Becky

Standings Senior Babe Ruth League

Standings Senior Babe Ruth League

Standings Senior Babe Ruth League

Standings Senior Babe Ruth League

Wynne's Inc. We have just taken on a new and rather unusual small car. The Subaru

The loss was the 15th in the last 16 games for Philadelphia and plunged the Phillies deeper in the East basement.

Ron Santo, Jim Hickman, and J.C. Martin smashed extra-base hits during a six-run rally in the first inning that powered Chicago past St. Louis. Bill Hands benefited from the outgame to win his fourth game in five decisions.

Standings Senior Babe Ruth League

Standings Senior Babe Ruth League

Standings Senior Babe Ruth League

Standings Senior Babe Ruth League

Standings Senior Babe Ruth League

Wynne's Inc. We have just taken on a new and rather unusual small car. The Subaru

The loss was the 15th in the last 16 games for Philadelphia and plunged the Phillies deeper in the East basement.

Ron Santo, Jim Hickman, and J.C. Martin smashed extra-base hits during a six-run rally in the first inning that powered Chicago past St. Louis. Bill Hands benefited from the outgame to win his fourth game in five decisions.

Standings Senior Babe Ruth League

Standings Senior Babe Ruth League

Standings Senior Babe Ruth League

Standings Senior Babe Ruth League

Standings Senior Babe Ruth League

Wynne's Inc. We have just taken on a new and rather unusual small car. The Subaru

The loss was the 15th in the last 16 games for Philadelphia and plunged the Phillies deeper in the East basement.

Ron Santo, Jim Hickman, and J.C. Martin smashed extra-base hits during a six-run rally in the first inning that powered Chicago past St. Louis. Bill Hands benefited from the outgame to win his fourth game in five decisions.

Standings Senior Babe Ruth League

Standings Senior Babe Ruth League

Standings Senior Babe Ruth League

Standings Senior Babe Ruth League

Standings Senior Babe Ruth League

Wynne's Inc. We have just taken on a new and rather unusual small car. The Subaru

The loss was the 15th in the last 16 games for Philadelphia and plunged the Phillies deeper in the East basement.

Ron Santo, Jim Hickman, and J.C. Martin smashed extra-base hits during a six-run rally in the first inning that powered Chicago past St. Louis. Bill Hands benefited from the outgame to win his fourth game in five decisions.

Standings Senior Babe Ruth League

Standings Senior Babe Ruth League

Standings Senior Babe Ruth League

Standings Senior Babe Ruth League

Standings Senior Babe Ruth League

Wynne's Inc. We have just taken on a new and rather unusual small car. The Subaru

The loss was the 15th in the last 16 games for Philadelphia and plunged the Phillies deeper in the East basement.

Ron Santo, Jim Hickman, and J.C. Martin smashed extra-base hits during a six-run rally in the first inning that powered Chicago past St. Louis. Bill Hands benefited from the outgame to win his fourth game in five decisions.

Standings Senior Babe Ruth League

Standings Senior Babe Ruth League

Standings Senior Babe Ruth League

Standings Senior Babe Ruth League

Standings Senior Babe Ruth League

Wynne's Inc. We have just taken on a new and rather unusual small car. The Subaru

The loss was the 15th in the last 16 games for Philadelphia and plunged the Phillies deeper in the East basement.

Ron Santo, Jim Hickman, and J.C. Martin smashed extra-base hits during a six-run rally in the first inning that powered Chicago past St. Louis. Bill Hands benefited from the outgame to win his fourth game in five decisions.

Standings Senior Babe Ruth League

Standings Senior Babe Ruth League

Standings Senior Babe Ruth League

Standings Senior Babe Ruth League

Standings Senior Babe Ruth League

Wynne's Inc. We have just taken on a new and rather unusual small car. The Subaru

The loss was the 15th in the last 16 games for Philadelphia and plunged the Phillies deeper in the East basement.

Ron Santo, Jim Hickman, and J.C. Martin smashed extra-base hits during a six-run rally in the first inning that powered Chicago past St. Louis. Bill Hands benefited from the outgame to win his fourth game in five decisions.

Standings Senior Babe Ruth League

Standings Senior Babe Ruth League

Standings Senior Babe Ruth League

Standings Senior Babe Ruth League

Standings Senior Babe Ruth League

Wynne's Inc. We have just taken on a new and rather unusual small car. The Subaru

The loss was the 15th in the last 16 games for Philadelphia and plunged the Phillies deeper in the East basement.

Ron Santo, Jim Hickman, and J.C. Martin smashed extra-base hits during a six-run rally in the first inning that powered Chicago past St. Louis. Bill Hands benefited from the outgame to win his fourth game in five decisions.

Standings Senior Babe Ruth League

Standings Senior Babe Ruth League

Standings Senior Babe Ruth League

Standings Senior Babe Ruth League

Standings Senior Babe Ruth League

Wynne's Inc. We have just taken on a new and rather unusual small car. The Subaru

The loss was the 15th in the last 16 games for Philadelphia and plunged the Phillies deeper in the East basement.

Ron Santo, Jim Hickman, and J.C. Martin smashed extra-base hits during a six-run rally in the first inning that powered Chicago past St. Louis. Bill Hands benefited from the outgame to win his fourth game in five decisions.

Standings Senior Babe Ruth League

Standings Senior Babe Ruth League

Standings Senior Babe Ruth League

Standings Senior Babe Ruth League

Standings Senior Babe Ruth League

Wynne's Inc. We have just taken on a new and rather unusual small car. The Subaru

Trevino Wants Cut From Sanudo

By BOB GREEN
Associated Press Golf Writer
CHARLOTTE, N.C. (AP) — Cesar Sanudo was recounting a fairway conversation that occurred while he was forging a seven-under-par 65 for the first-round lead in the \$175,000 Kemper Open Golf Tournament.

"I'd borrowed this putter from Lee Trevino just the day before," the obscure Sanudo said Thursday after putting his signature to the best round of his pro career.

"And I was playing just in front of Lee. He saw me making all those putts and all those birdies and he yelled at me. 'So I yelled back at him. 'Okay, if I can have 30 per cent of yours for the year.'"

It wouldn't be a bad deal for the 28-year-old Sanudo, a Mexican-born American citizen now in his fourth year on the pro tour. He's won but \$5,755 this season opposed to Trevino's \$98,447 and last year pocketed only \$18,031 while Trevino took home \$231,202. He's never chal-

lenged seriously in a major event.

More than 50 of the touring pros were able to match or better par 72 on the 7,278-yard Quail Hollow Country Club course, but only Billy Casper could stay close to blithe spirit Sanudo, a quick man with a quip and ever ready with a smile.

The veteran Casper, who tied for first only to lose in a play-off in his last American start a month ago, had a pair of eagle threes en route to a 66, just one stroke back.

Veteran Charles Sifford, a Charlotte native who broke the color line in golf, Chris Blocker and Gibby Gilbert were next at 68. Trevino and England's Tony Jacklin were in a group of more than a half-dozen who had 69s in mild, sunny weather.

Arnold Palmer, Sam Snead and George Archer were in a group of more than a dozen at 70—a distant five strokes off the pace—and South African Gary Player and defending titleholder Tom Weiskopf had 72.



A Casper Blast

Billy Casper of Chula Vista, Calif., is almost hidden by sand as he blasts from the trap on the 12th green during first round play of the Kemper Open. Casper parred the hole and finished play with a six-under-par 66, one stroke behind leader Cesar Sanudo of El Cajoh, Calif. (AP Wirephoto)

Richmond Big Loser In NCAA

GASTONIA, N.C. (AP) — Virginia, South Alabama and previous title winner Mississippi carried first round victories into today's games of the National Collegiate Athletic Association District 3 baseball tournament with at least one team destined to bow out of the double elimination affair.

First round losers Florida State and Richmond met in the morning game with the loser being eliminated. The afternoon game had South Alabama against once beaten Jacksonville and Virginia meets Ole Miss in the evening game. Jacksonville also is out if it loses.

In opening play Thursday, Virginia demolished Richmond, 18-2, in the day's most decisive victory. South Alabama downed Florida State, 6-5, and Mississippi defeated Jacksonville,

9-3.

The victory was Mississippi's ninth straight over its years of appearances in the District 3 tournament, which it won in 1956, 1964 and 1969. Ole Miss is 11-1 in district play.

Jim Pittman pitched the distance for Ole Miss, giving up six hits, four in the first inning when Jacksonville scored three runs. In getting his ninth victory against one loss, Pittman walked eight and struck out 10.

Virginia already was leading 9-1 when it poured on nine more runs in the seventh inning as it overpowered Richmond. All of the last nine runs were unearned.

South Alabama managed to push across two runs in the eighth inning, including Pete Phillips' lead off homer, to come from behind for its margin of victory.

Blalock Files \$5 Million Suit

ATLANTA (AP) — Jane Blalock, one of the most promising young players on the Ladies Professional Golf Association tour, countered a one-year suspension Thursday by filing a \$5 million lawsuit against the organization.

The suspension "for actions inconsistent with the code of ethics of the organization" was announced there Thursday by E. M. "Bud" Erickson, LPGA executive director, only hours before two New York attorneys filed the suit on Miss Blalock's behalf in U.S. District Court.

The suit also seeks a court order to permit Miss Blalock to compete in tournaments while the case is being resolved. Judge Charles A. Moyer Jr. scheduled a hearing on that motion for 10 a.m. today in his chambers.

Miss Blalock, a 26-year-old blue-eyed blonde from Portsmouth, N.H., is the leading money winner on the LPGA tour this year with \$32,886.

In only her fourth year on the tour, she already has won honors as rookie of the year in 1969 and most improved golfer in 1970 and 1971. She placed third in the Vare Trophy standings last year, based on stroke average per round.

The suit was filed on her behalf by New York attorneys Lawrence Kill and Gerold Oshinsky. It seeks a jury trial and alleges violation of antitrust law.

Miss Blalock is asking for damages of not less than \$1 million, to be trebled as provided by law. She also seeks \$1 million for compensatory damages and \$1 million for punitive damages.

Defendants in the suit are the LPGA, its Tournament Players Corp., its officers, Erickson and Gene McCauliff, tournament director. The LPGA has its headquarters in Atlanta.

Erickson said the suspension was taken after Miss Blalock met with the executive committee three times in the last 10 days. He said she was advised of the suspension Tuesday night.

Miss Blalock wasn't available for comment on the matter and Erickson declined to comment on her lawsuit. "We will answer the complaint at the proper time," he said.

Erickson called the suspension "an unfortunate thing. It was a traumatic decision that the executive committee made. For the best interest of the organization and for the best interest of golf, they felt we had to make it."

Richard Blalock, the golfer's father, said he hadn't heard from his daughter since the suspension was announced.

Grace Takes Over Lead In National Division

Oakmont, Grace, and Black Jack all took wins in Church League action last night. All three games were make-up games that had been previously washed out.

In the opener, Oakmont outlasted St. James, 15-13. St. James broke the ice in the first with a lone run but Oakmont moved ahead with three in their half of the inning. St. James rallied for eight runs to move out by 9-3.

After Oakmont got a lone score in the second, St. James increased its lead to 13-4 with four in the fourth. J.J. Harris slammed a home run for the first score. E. Mann got a hit as did M. Board. D. Dearmer and J. Ritch got hits to score Mann and Board and a pair of ground outs let the other runs come across.

Oakmont fought back and got five in the fourth, and four in the fifth to tie the game at 13-13. Nash Love led off the sixth for Oakmont with a double and scored on a hit by H. Smithson to put Oakmont ahead for the first time. Smithson moved up on an out and scored on a hit by D. Daugherty.

In the second game, Grace moved into first place with a close win over Immanuel, 16-14.

After a scoreless first inning, Grace got on the boards with three in the second. Immanuel came back to take the lead with seven runs in the third but Grace got three in the third to cut the lead to 7-6.

Immanuel got added to their score with three in the next frame but Grace got a pair of their own. Grace took the lead in the sixth as they rallied for five runs to move out by 13-10. Immanuel forged back to regain the lead in the seventh with four runs.

R. Dixon singled as did J. T. Mills. T. Adams got a double to clear the bases and a hit by P. Smith drove in Adams. Smith came in on a hit by B. Elks.

The win by Oakmont gives them a 4-2 record while St. James drops to 2-3. Immanuel 4-2 is a half game back of National Division leader Grace, 5-2. Black Jack is 3-2 while Mt. Pleasant falls to 2-4.

The Optimists gained a share of first place in the North State Little League yesterday with a 6-1 victory over the Jaycees.

The win brought the Optimists to 3-1 in the league, tying Coca-Cola for the lead. The Jaycees fell off to 3-3 with the loss.

The Jaycees pushed into the lead in the second inning, scoring a run. Lance Weatherington led off, walking. Joey Mathies also walked, and both advanced on a wild pitch. Greg Guthrie bunted his way aboard, loading the bases and Bill Collier singled in Weatherington for a 1-0 lead.

and errored, scoring Allen. Rowlette also scored on an error. Moore scored after Mac Stokes and Eric McCormick both walked, making it 3-1.

The fourth saw the other three Optimist runs come across. Moore walked and Shoe singled. Stokes then cracked a three-run homer to finish off the scoring.

Collier led the Jaycee hitting with three, while Guthrie had two. For the Optimists, no one had more than one hit.

Jaycees 010 000—161
Optimists 030 30X—641

Hurtubise Mad Over Dropping

INDIANAPOLIS (AP) — Add Jim Hurtubise's name to the list of drivers disgruntled with Saturday's Indianapolis 500-mile race.

Hurtubise was dropped from 18th to 23rd, and he's not happy about it. In fact, he says he may quit the U.S. Auto Club.

The popular driver was shoved down seven places because his racer was hauled across the infield to the pits after running out of fuel during the race.

"They let me drive 200 miles, nearly half the race," Hurtubise said by telephone from his North Tonawanda, N.Y., garage. "I think there is a lot of straightening out needed in a lot of places. If they think I'm out there for my health they are mistaken."

Hurtubise said he "nearly had a fist fight" with track attendants who gave him a tow.

Chief steward Harlan Fenger told drivers at the pre-race meeting any car stalled on the track would have to go around the course, Hurtubise said.

Attendants told him he couldn't go around and hauled him across the infield to the pits, where the car was refueled and returned to the race.

"There is a definite lack of communication between the steward and attendants," Hurtubise said.

DID YOU KNOW ?

...Senator Everett Jordan voted for a bill seeking up a program to attack the drug problem.

Congressman Galifianakis did not bother to vote...not once, but three times on drug bills this year.

NOW YOU KNOW! VOTE JORDAN

Committee To Re-elect Senator Jordan
Cliff Everett, Jr., Chairman

SUMMER SALE

AT
FOLGER'S BUICK-OPEL

Take your vacation in a BUICK Comfort Style Confidence

Electra 225 Limited Sport Coupe

... That's Buick at the best prices ever. More car for your money — More money for your car. Top trade allowance on clean used cars.

Ask about our lease plan.

PERSONALIZED SALES AND SERVICE OPEN TIL 7:00 DAILY 2:00 SATURDAY

FOLGER BUICK CO.

117 W. 10th St. Greenville, N.C. Phone 758-1123
"BIG ENOUGH TO SERVE YOU, SMALL ENOUGH TO KNOW YOU"

The Optimists came up with three in their half of the second to move into the lead for good. Gary Allen was hit by a pitch to open the frame. Bubba Rowlette singled and Glenn Moore walked. James Shoe reached on a fielder's choice when his grounder was played to home

HOLIDAY PAIRINGS SET
NEW YORK (AP) — South Carolina, Michigan, Tennessee, Boston College, Manhattan, Niagara, St. John's and Villanova will compete in the Holiday Festival basketball tournament in Madison Square Garden Dec. 26-30.

It's A Blast!

Putt-Putt Golf NOW OPEN

Hours:
3 P.M.-10 P.M. Monday-Thursday
3 P.M.-11 P.M. Friday
9 A.M.-11 P.M. Saturday
1 P.M.-11 P.M. Sunday

Putt-Putt
E. 10th St. Extension

Near 264 By-Pass on the Washington Highway
Phone 758-1820
Make Friends Playing Putt-Putt

Canada Dry. Now available in 2 grown up flavors.

Fortunately, the prices are still a generation behind.



Gin 90 Proof, Vodka 80 Proof, Both 100% Grain Neutral Spirits, Bottled by Canada Dry Distillers Co., Nicholasville, Kentucky.

Putt County's Exclusive Chrysler, Plymouth, Dodge & Dodge Truck Dealer

1969 Dodge Coronet 4 door sedan, full power including factory air conditioning, white with black vinyl top. **\$1695**

1969 Dodge Coronet 4 door sedan, full power including factory air conditioning, white. **\$1595**

1969 GMC Truck, 159" wheel base, newly rebuilt engine. **\$1595**

1969 Dodge Monaco, full power including factory air conditioning. **\$1995**

1969 Dodge Dart, 2 door hardtop, 6 cylinder, automatic transmission. **\$1495**

1968 Plymouth Fury III, 2 door hardtop, V-8, straight drive. **\$1095**

1968 Plymouth Satellite, 4 door sedan, 6 cylinder, automatic transmission, power steering. **\$1195**

1967 Oldsmobile 88, 4 door sedan, full power including factory air conditioning. **\$1295**

1967 Dodge Dart, 4 door sedan, automatic transmission. **\$895**

1967 Plymouth Fury III, 4 door hardtop, V-8, automatic transmission, power steering. **\$995**

1967 Mercury Monterey, 2 door hardtop, V-8, automatic transmission, power steering. **\$995**

1967 Plymouth Barracuda, 2 door hardtop, V8, automatic transmission, power steering. **\$795**

1967 Chrysler Newport, 4 door sedan, V8, automatic transmission, power steering & brakes. **\$1095**

1967 Ford F-100 Pick-up, V8 engine, long body, green & white. **\$1295**

1967 Ford Pickup, long body, 6 cylinder engine, one owner. **\$1195**

1966 Dodge Monaco, 4 door hardtop, full power including factory air conditioning, beige, black vinyl roof. **\$895**

1966 Chevrolet Impala, 2 door hardtop, V8, automatic transmission, power steering. **\$695**

1966 Plymouth Fury III, 6 passenger wagon, V8, automatic transmission, power steering. **\$995**

1966 Dodge Polara, 4 door sedan, full power including factory air conditioning. **\$795**

1966 Pontiac Catalina, 4 door sedan, full power including factory air conditioning. **\$795**

1965 Plymouth Fury III, 4 door hardtop, V8, automatic transmission, power steering. **\$595**

1965 Plymouth Fury III, 6 passenger wagon, V8, automatic transmission, power steering. **\$650**

1965 Chevy II, 4 door sedan, 6 cylinder, straight drive. **\$395**

1965 Chrysler "300" 4 door hardtop, full power including factory air conditioning. **\$695**

1965 Pontiac Grand Prix, 4 door hardtop, full power including factory air conditioning. **\$795**

1964 Plymouth Belvedere, 4 door hardtop, V8, automatic transmission, power steering. **\$595**

1964 Valiant Convertible, V8, automatic transmission. **\$195**

1964 Mercury Monterey, 4 door hardtop. **\$195**

1964 Chevrolet Bel Air, 4 door sedan, V8, automatic transmission, 49,000 actual miles. **\$595**

1963 Volkswagen, new rebuilt engine. **\$595**

1963 Plymouth Valiant, 6 cylinder, automatic transmission. **\$450**

1963 Rambler wagon. **\$195**

1963 Chevrolet Bel Air wagon. **\$295**

1962 Lincoln Continental, 4 door full power including factory air conditioning, real nice. **\$695**

BRIGHT LEAF MOTORS, INC.
Memorial Drive at U.S. 264
Greenville, N.C.
Phone 758-0186

Today's Baseball

Today's Baseball
By THE ASSOCIATED PRESS
American League

East			
	W.	L.	Pct. G.B.
Detroit	21	17	.553 —
Baltimore	20	17	.541 ½
Cleveland	19	17	.528 1
Boston	16	19	.457 3½
New York	17	21	.447 4
Milwaukee	13	22	.371 6½
West			
Oakland	25	12	.676 —
Minnesota	23	13	.639 1½
Chicago	22	16	.579 3½
California	18	23	.439 9
Texas	17	24	.415 10
Kansas City	14	26	.350 12½

Thursday's Results
Kansas City 5, Minnesota 3
Milwaukee 9, New York 8, 12
innings

Boston 7, Baltimore 1
Cleveland 1, Detroit 0
Only games scheduled

Friday's Games
Oakland (Blue 0-0) at Baltimore (Palmer 5-3), N
California (Wright 3-2) at Cleveland (Colbert 0-2), N
Texas (Gogolewski 3-4) at Milwaukee (Lonborg 2-2), N
Boston (Krausse 1-2) at Kansas City (Drago 2-4), N
Minnesota (Kaat 6-1) at Detroit (Lolich 8-3), N
New York (Peterson 3-6) at Chicago (Bradley 5-2), N

Saturday's Games
Oakland at Baltimore
California at Cleveland
Texas at Milwaukee
Boston at Kansas City
Minnesota at Detroit
New York at Chicago

National League

East			
	W.	L.	Pct. G.B.
New York	30	11	.732 —
Pittsburgh	24	15	.615 5
Chicago	21	18	.538 8
Montreal	18	22	.450 11½
St. Louis	17	25	.405 13½
Philadelphia	16	25	.390 14

West			
	W.	L.	Pct. G.B.
Los Angeles	26	17	.605 —
Cincinnati	24	18	.571 1½
Houston	24	18	.571 1½
Atlanta	18	22	.450 6½
San Diego	16	26	.381 9½
San Francisco	16	31	.340 12

Thursday's Results
Chicago 7, St. Louis 3
New York 6, Philadelphia 1
Cincinnati 10, Houston 3
San Francisco 5, Los Angeles 2

Only games scheduled
Friday's Games
Cincinnati (Grimsley 2-1) at Philadelphia (Fryman 2-3), N
Houston (Griffin 1-1) at Montreal (Torrez 4-2), N
Atlanta (Niekro 6-4) at New York (Gentry 3-2), N
Chicago (Houston 4-4) at San Diego (Kirby 3-5), N
St. Louis (Cleveland 4-3) at Los Angeles (John 3-3), N
Pittsburgh (Johnson 0-2) at San Francisco (Marichal 1-8 or Carrithers 1-3), N

Saturday's Games
Cincinnati at Philadelphia
Houston at Montreal, N
Atlanta at New York
Chicago at San Diego, N
St. Louis at Los Angeles, N
Pittsburgh at San Francisco

Saturday's Sports

Baseball
Babe Ruth League
Carolina Dairy vs. Planters Bank
College View vs. NCNB
Home Builders vs. Pepsi-Cola
Little League
Optimists vs. Lions
Coca-Cola vs. Kiwanis
Graniteers vs. Moose
American Legion
Greenville at Hamlet
3-A Playoffs
Greene Central at Northwest Cabarrus (if necessary)
Sr. Babe Ruth
Big Value Discount at Taff Office
1-A Playoffs
Rowland at Robersonville

Bowling

City League		
	W	L
Chatham Hot Dogs	82	50
Applied Systems	81	51
Comedy Of Errors	81	51
Challengers	78	54
Bob's Homes	73	59
Piggly Wiggly	71	61
Trophy House	69	63
Thorpe Music	59	73
Alpha & Omega	59	73
Nelson Realtor	57	75
Upsets	48	84
VEPCO	34	98

High game, J.P. Jones, 247;
high series, Billy Whitehurst, 629.

Spring Chicks		
	W	L
Hilltoppers	9	3
Sugar Cookies	7	5
Three Clucks	7	5
Three Nuts	6	6
Egg Heads	4	8
Purple Peacocks	3	9

High game and series, Eileen Huber, 159, 428.

Aerospace professor helps Royal with regulation golf ball that flies 6 yards farther than country's number one ball.

Three years ago, we at Royal approached Dr. John Nicolaides—Professor of Aerospace, University of Notre Dame, and one of the country's foremost authorities on aerodynamics—and asked him if he'd help us with a regulation golf ball that would fly farther than any other regulation golf ball.

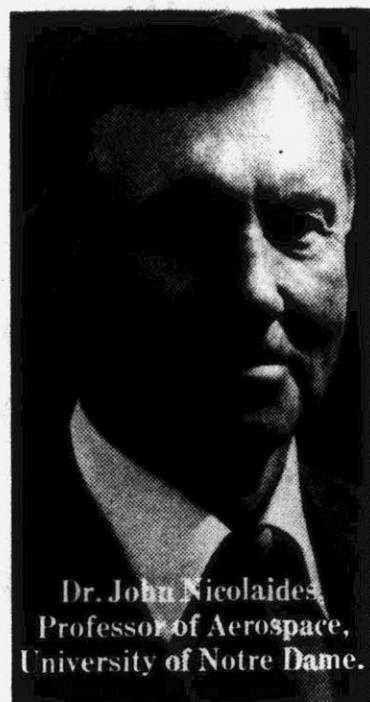

Dr. John Nicolaides, Professor of Aerospace, University of Notre Dame.

It turned out that for years Dr. Nicolaides had been intrigued by the flight of the golf ball, which he describes as completely unique, completely different from a baseball, a football or a tennis ball. ("In flight," says Dr. Nicolaides, "the golf ball literally has wings.")

To understand how Dr. Nicolaides approached the problem, it is first necessary to know a little about the history of golf balls.

In 1848, golf balls had smooth coverings made out of the gum of a tree. When these balls were hit, they flew out, then suddenly dove down into the ground. However, after this ball was played a number of times and its cover was marked up, it flew much farther.

As a result, people began putting all kinds of markings on the covers of balls to

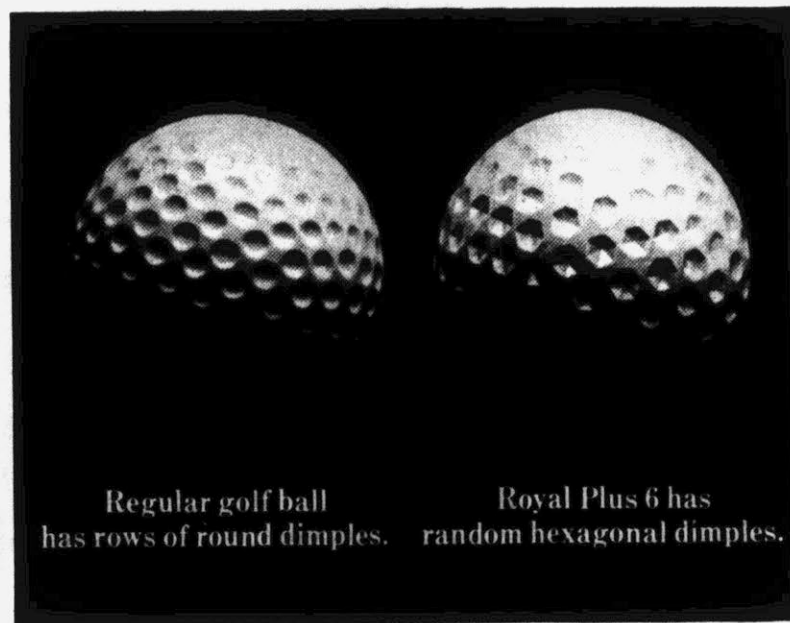

Regular golf ball has rows of round dimples. Royal Plus 6 has random hexagonal dimples.

give them better flight performance. (Our present dimpled ball is simply a reversed version of a ball with little bumps all over it that was used at the turn of the century.)

So the key questions were: Why do the markings on the surface of golf balls influence flight performance? And, more important, how can we mark the surface of a ball to make it fly even farther?

Dr. Nicolaides' unique sub-sonic wind tunnel proved invaluable in measuring the effects of various types of surface markings on the factors at work in the flight of a golf ball: the velocity and angle the ball is given when it's hit by the club; the under-spin that gives the ball its lift force (its "wings" if you will); the drag force (wind resistance) pulling backwards trying to slow the ball down; and, of course, the gravity force pulling down.

All this aerodynamic data was fed into computers, and the exact positions of balls with different surface markings—as they fly through the air from tee to point of impact—were plotted.

It is here that Dr. Nicolaides first saw the increased range of a ball with random

hexagonal dimples as opposed to rows of round ones. (It seems that this type of surface marking produced better lift and less drag.)

With all the theoretical work done, Dr. Nicolaides then set out to confirm his findings on the golf course. To do this, he designed a completely unique golf-ball-hitting machine, which hits each ball with exactly the same force and at exactly the same angle.



After the ball proved itself in the lab, it was tested on the course.

After many, many hits using regular round-dimpled balls (Titleist K-types were used) and many, many hits using hexagonal-dimpled balls, Dr. Nicolaides saw that the new hexagonal-dimpled ball flew an average of 6 yards farther.

Which is why we at Royal chose to call this revolutionary new ball the Royal Plus 6.

Royal Plus 6

Available now at golf professional shops. Ask your pro about it.

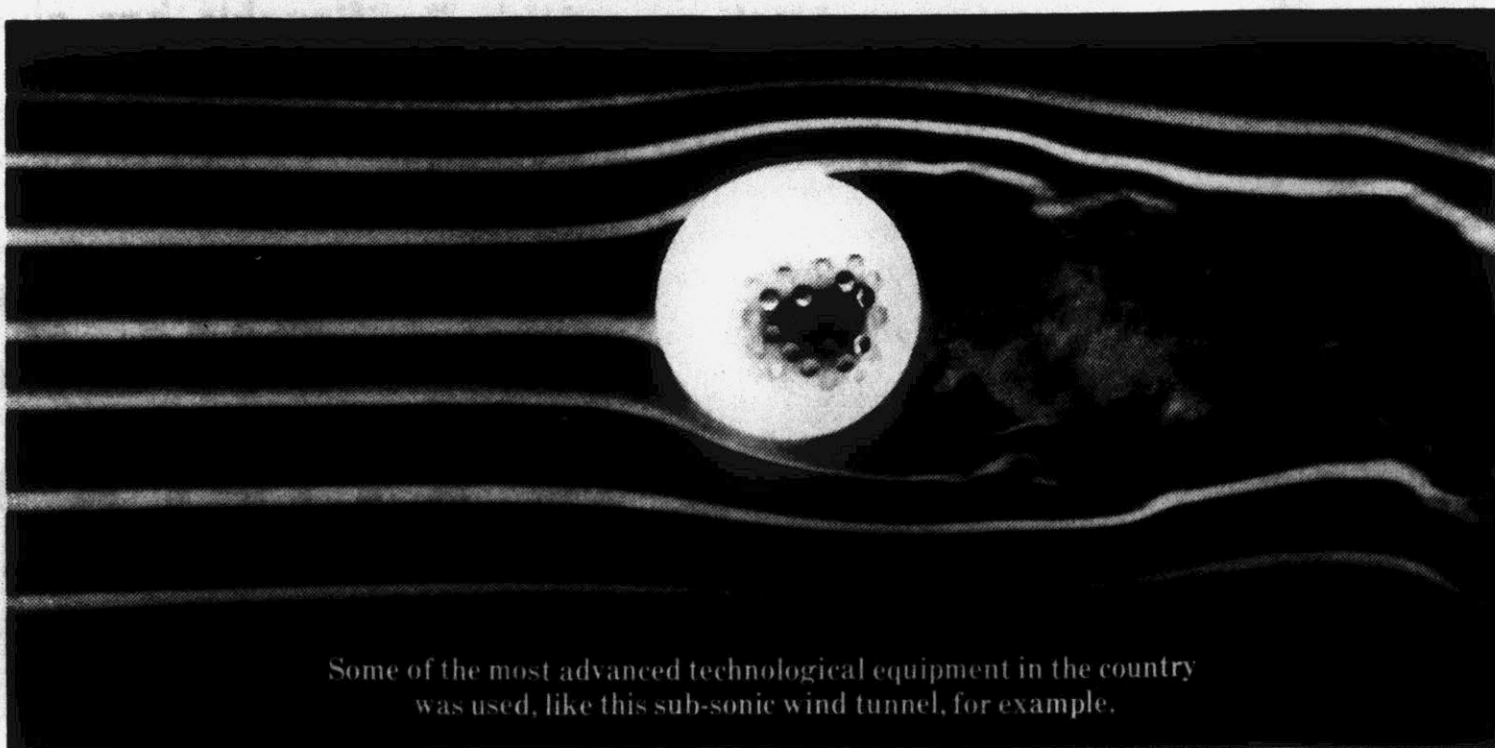
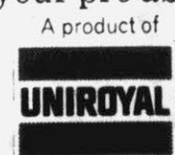

Some of the most advanced technological equipment in the country was used, like this sub-sonic wind tunnel, for example.



BALLET TO BELLYDANCING — Shapely Anne Lippe balances a sword while swirling hips during bellydance demonstration. The 28-year-old former debutante bought a cheap pair of cymbals on a jaunt to the Mediterranean then traded ballet for bumps and grinds to learn how to use them. (AP Wirephoto)

Galifianakis . .

(Continued from page 1)

during the 5-year period from February 1965 to 1970 when that export threat really developed."

The Senate hopeful said he attributes part of Jordan's "bluster regarding agriculture" to his reaction to "a major piece of tobacco legislation which I introduced in the Congress this week."

Galifianakis explained, "This bill calls for a 'matching dollar' program of federal grants for tobacco research and will require the federal government to spend one dollar for research benefiting tobacco production for every dollar spent on studies linking smoking and disease."

He said the measure seeks to counter-balance all the anti-tobacco research going on and hopefully will enable scientists to alter the chemical or genetic components of the leaf if one or more of the components are ever conclusively identified as causing disease.

"This should help preserve an industry vital to North Carolina's economy," Galifianakis emphasized.

The candidate too, countered Jordan's contention that the incumbent has a better voting record in the congress than himself.

"During the five full years I have been in Congress, my voting attendance record averages 91.4 per cent. During that period I had to stand for reelection twice."

For those same five years my opponent's attendance averages 81 per cent, or 10 per cent less than mine, and he did not have to campaign once."

Looking at the first five months of this year, Galifianakis said "I freely admit my attendance has fallen because I thought it was important that I campaign among the people of North Carolina."

But, he noted, "the record of my opponent has also fallen during the campaign period. He says he did not campaign much in the first primary, and yet he attended only 40 per cent of the votes since March 1."

"Interestingly, since May 6

Elaborate Judicial Strategy Is Ready For Convention Disorder

Brought Savings To Hospital, Too

SAN DIEGO, Calif. (AP) — Patients at University Hospital aren't supposed to keep more than \$5 in their rooms. A 69-year-old man with an abdominal condition broke that rule—by \$34,995.

Hospital orderly Robert Cardenez was chatting with the patient Thursday when he noticed the man had a number of bills in his wallet. Cardenez suggested he check the money in the hospital safe.

The patient, whose name was not released, agreed, pointed to an old suitcase and said, "We might as well check this, too." Inside was the rest of the \$35,000.

Hospital officials said the man has no relatives and apparently brought his life savings with him when he checked in 10 days ago.

When asked one of the first things he could do if elected to the Senate, Galifianakis said "take a look at American foreign policy...what part tobacco will play in world trade."

"I am very interested in tobacco. It is important to the entire nation."

According to Galifianakis, "a press conference really isn't the best forum to settle all these differences over the record."

The issues could have easily been resolved, Galifianakis said, "had my opponent accepted any one of three invitations by television stations to appear jointly with me to discuss these issues. Unfortunately, he did not."

MIAMI BEACH, Fla. (AP) — Circuit Court Judge Thomas Lee has announced an elaborate judicial strategy aimed at coping with any disorders at this summer's national political conventions.

"We've seen justice decrease in other areas during civil disorders," Judge Lee said Thursday. "That will not happen here."

Anyone who gets arrested can expect to be swiftly escorted to a secret staging area and be photographed, fingerprinted and booked.

Dade County plans to keep its Magistrate Court going around the clock, with lawyers, prosecutors and bailiffs on instant call during the Democratic convention July 10-13 and the Republican gathering Aug. 21-24.

Officials here have noted techniques utilized on other occasions in Chicago or Washington—such as "mass arrests" by policemen who sometimes wore no name tags.

"Our people always wear their name tags," said Police Chief Rocky Pomerance. "They will never take off their badges."

Judge Lee said the arresting officer will bring the accused to

one of several "staging areas" to be set up at sites, not to be publicly disclosed, near Miami Beach Convention Hall.

The policeman is to swear his complaint before a court clerk. After being searched and having his right thumbprint taken, the arrested person will be transported to downtown Miami's Metro Justice Building to be booked.

Juveniles are to be separated from adults, men from women, and felony suspects from those accused of less serious crimes.

County court officers aim to assure uniform bail for like offenses, quick arraignment for the accused and procedural rights for all.

The American Civil Liberties Union, the Florida Bar Association and the County Public Defender's Office have said they will provide lawyers as needed to represent convention demonstrators. The state attorney and the county attorney likewise aim to have their aides up late at night, advising police on questions of evidence and booking.

Persons arrested for public disorder, inciting to riot and similar charges will not be brought to trial until peace returns to the community so that everyone will have a chance to "calm down," Judge Lee said.

Otherwise, prosecution of offenders is supposed to be swift.

Never Part Of Sanford Administration: Taylor

By JAY HENSLEY
For The Associated Press
RALEIGH (AP) — Lt. Gov. Pat Taylor admitted Thursday that he supported Terry Sanford in his bid for the governorship in 1960. But Taylor said that unlike Hargrove "Skipper" Bowles, his opponent in Saturday's runoff Democratic gubernatorial primary, he was never part of the Sanford administration.

Taylor, who had charged that Bowles is part of a Sanford political machine, said earlier in the day Thursday that Sanford's followers held a secret

meeting at Hound Ears in western North Carolina prior to the 1968 election to decide whether they would run Bowles or Bob Scott for governor.

The Sanford people were split on the question at the time, Taylor said. Scott ran, won the nomination, and was elected.

Taylor was asked Thursday by a panelist on a WUNC-TV news program in Chapel Hill about a list of key campaign workers for Sanford. Ned Cline of the Greensboro Daily News told Taylor he has seen a list of key Sanford workers which showed Taylor as manager of a three-county area in 1960. Bowles was not on the list, Cline said.

Taylor said he doesn't doubt that he was listed as a key manager in the Sanford campaign, but feels certain that it was only for organization purposes.

"But I did support him, yes, but I was not part of his administration," Taylor said.

Bowles was appointed by Sanford to head the Department of Conservation and Development, and Taylor says it was a payoff for his work in the campaign. The university

television program was taped Thursday and will be shown tonight, as will a separate panel interview with Bowles.

Taylor planned to spend the final day before the runoff at his campaign headquarters in Raleigh. He will go to Polkton Saturday to speak at groundbreaking ceremonies for a new industry, after voting in his hometown of Wadesboro.

Rose High . . .

(Continued from page 1)
we believe must determine what we do."

Invocation for the graduation exercise was given by Robert Troy Barret, who at one point asked the Lord "to help us keep our cool."

Dr. Cleet C. Cleetwood, Superintendent of the Greenville City Schools, presented the graduating class to the School Board. Diplomas were awarded by John H. Bizzell, vice-chairman of the school board. Robert Allgood, principal of Rose High, called the names of the students as they mounted the stage in alphabetical order.

The tassel ceremony was performed by Kelly Darden, Jr., Brenda Murray and Jesse Daniels.

Battled Flames Inside A Freezer

CINCINNATI, Ohio (AP) — On a mild Thursday in June, firemen had to battle a fire in temperatures about 40 degrees below zero.

The blaze erupted in a freezer at the French Bauer Co. a dairy products manufacturer, when an acetylene torch being used to thaw a conveyor belt ignited a set of plastic ice cream containers, officials said.

Nick Galifianakis fights for North Carolina's farmers, and he wins.

- As a member of the powerful House Appropriations Committee, Nick has fought for funds for every agriculture and rural program in this country.
- Fought successfully to increase R.E.A. funds by \$200 million dollars in 1971.
- Introduced Farm Credit Legislation which passed into law as part of the Farm Credit Act of 1971.
- Fought successfully to free "frozen" Farmers Home Administration loan funds which resulted in more than \$2 million extra dollars for North Carolina farmers this year.
- Has introduced strong tobacco legislation, including a new bill which calls for the federal government to allocate \$8700,000 a year for research to benefit tobacco growers and processors.
- As a lifelong resident of Durham—a town which thrives on the success of tobacco—Nick Galifianakis has always understood the importance of tobacco and agriculture to the economic well-being of North Carolina.

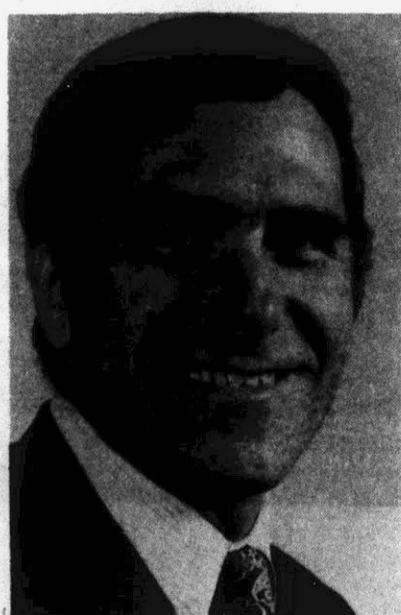

NICK GALIFIANAKIS

United States Senate

Pitt County Committee For Nick Galifianakis — Leon L. Moore, Jr., Chairman

How is George Dickel?

Gratifying! It's real Tennessee Sippin' Whisky.

Gentle! It's mellowed through charcoal.

Busy! Hard at work making every drink smooother.



The bourbon drinker's impossible dream.



Approve Highway Project Bids

RALEIGH (AP) — The State Highway Commission approved

Thursday low bids totaling more than \$12.3 million for 10 road projects in 12 counties.

One other low bid was rejected by the commission. It was \$84,685 by Bryant Electric Co. of High Point for upgrading electric traffic signals at five intersections on N.C. 24 in and near Fayetteville.

Bids approved included: Buncombe County — 10.831 miles of lighting on Interstate 26 and 40, NC 191 connector and US 19-23 in and near Asheville, \$796,749. M.B. Haynes Electric Corp. Final completion date July 1, 1973.

resurfacing four sections of primary roads and three sections of secondary roads on US 17-264 and 33 (part), \$221,948. Barrus Construction Co., Winston, N.C. Final completion date Nov. 1, 1972.

Arrest Man For Threats

SAN FRANCISCO (AP) — Police said a 35-year-old man was arrested Thursday night for making death threats against Sens. Hubert H. Humphrey and George McGovern, leading contenders for the Democratic presidential nomination.

A police spokesman said operators at the Hall of Justice got three telephone calls in fairly quick succession, the first threatening a shooting at the Cow Palace, the second against the life of Humphrey, the third against McGovern.

"He said he was going to assassinate these people," the spokesman said.

The man in custody was not immediately identified and it was not known if he would be booked.

The police spokesman said the call was traced by the telephone company, and after more than an hour of searching Secret Service agents made the arrest.

Police said the Cow Palace threat might have been associated with the fact Sen. Humphrey visited a televised auction benefit there for about 30 minutes during the evening.

Robeson County — 33 miles of improvements on SR 1800 (Shaw Street) and SR 1734 (Old Stage Road) in St. Pauls, \$33,912. C. W. Mathews Construction Co., Fayetteville. Final completion date Oct. 1, 1972.

Alamance County — 7.67 miles of bituminous concrete surface for resurfacing six sections of primary roads and eight sections of secondary roads on US 70, NC 62, 54 and 87 (part), \$147,224. Thompson-Arthur Paving Co., Greenville, N.C. Final completion date Oct. 1, 1972.

Catawba County — 20.11 miles of bituminous concrete surface and bituminous seal coat for resurfacing five sections of primary roads and sev-

en sections of secondary roads, \$167,451. Midstate Contractors, Hickory. Final completion date Nov. 1, 1972.

Gaston-Lincoln counties — 24.92 miles of sand, asphalt surface, bituminous concrete surface and bituminous seal coat for resurfacing three sections of primary road and 21 sections of secondary roads, \$211,565. Rea Construction Co., Charlotte. Final completion date Nov. 1, 1972.

Iredell County — 20.86 miles of bituminous concrete surface and bituminous seal coat for resurfacing four sections of pri-

mary roads and one section of secondary road on I77 US 21 and NC 90 (part), \$114,245. Rea Construction Co., Charlotte. Final completion date Nov. 1, 1972.

Farmville Central

A line under the graduating seniors photos in Thursday's Daily Reflector referred to Farmville High School.

The correct name of the new high school is Farmville Central High School.

The correct name of the new high school is Farmville Central High School.

The correct name of the new high school is Farmville Central High School.

The correct name of the new high school is Farmville Central High School.

The correct name of the new high school is Farmville Central High School.

The correct name of the new high school is Farmville Central High School.

The correct name of the new high school is Farmville Central High School.

The correct name of the new high school is Farmville Central High School.

The correct name of the new high school is Farmville Central High School.

The correct name of the new high school is Farmville Central High School.

The correct name of the new high school is Farmville Central High School.

The correct name of the new high school is Farmville Central High School.

The correct name of the new high school is Farmville Central High School.

The correct name of the new high school is Farmville Central High School.

The correct name of the new high school is Farmville Central High School.

The correct name of the new high school is Farmville Central High School.

The correct name of the new high school is Farmville Central High School.

The correct name of the new high school is Farmville Central High School.

The correct name of the new high school is Farmville Central High School.

The correct name of the new high school is Farmville Central High School.

The correct name of the new high school is Farmville Central High School.

The correct name of the new high school is Farmville Central High School.

The correct name of the new high school is Farmville Central High School.

The correct name of the new high school is Farmville Central High School.

The correct name of the new high school is Farmville Central High School.

The correct name of the new high school is Farmville Central High School.

The correct name of the new high school is Farmville Central High School.

The correct name of the new high school is Farmville Central High School.

The correct name of the new high school is Farmville Central High School.

The correct name of the new high school is Farmville Central High School.

The correct name of the new high school is Farmville Central High School.

The correct name of the new high school is Farmville Central High School.

The correct name of the new high school is Farmville Central High School.

The correct name of the new high school is Farmville Central High School.

The correct name of the new high school is Farmville Central High School.

The correct name of the new high school is Farmville Central High School.

The correct name of the new high school is Farmville Central High School.

The correct name of the new high school is Farmville Central High School.

The correct name of the new high school is Farmville Central High School.

The correct name of the new high school is Farmville Central High School.

The correct name of the new high school is Farmville Central High School.

The correct name of the new high school is Farmville Central High School.

The correct name of the new high school is Farmville Central High School.

The correct name of the new high school is Farmville Central High School.

The correct name of the new high school is Farmville Central High School.

The correct name of the new high school is Farmville Central High School.

The correct name of the new high school is Farmville Central High School.

The correct name of the new high school is Farmville Central High School.

The correct name of the new high school is Farmville Central High School.

The correct name of the new high school is Farmville Central High School.

The correct name of the new high school is Farmville Central High School.

The correct name of the new high school is Farmville Central High School.

The correct name of the new high school is Farmville Central High School.

The correct name of the new high school is Farmville Central High School.

The correct name of the new high school is Farmville Central High School.

The correct name of the new high school is Farmville Central High School.

The correct name of the new high school is Farmville Central High School.

The correct name of the new high school is Farmville Central High School.

The correct name of the new high school is Farmville Central High School.

The correct name of the new high school is Farmville Central High School.

The correct name of the new high school is Farmville Central High School.

The correct name of the new high school is Farmville Central High School.

The correct name of the new high school is Farmville Central High School.

The correct name of the new high school is Farmville Central High School.

The correct name of the new high school is Farmville Central High School.

The correct name of the new high school is Farmville Central High School.

The correct name of the new high school is Farmville Central High School.

The correct name of the new high school is Farmville Central High School.



RYE PROTECTS CROP . . . Leon Raymond Hardee examines his tobacco crop in the Chicod Creek Watershed area. The tall strips of rye grass protected the plants against wind and sand

damage. The conservation treatment of land as shown here is just one of the many conservation measures used on the farm.

Day Of Handshaking To Close Jordan Campaign

WINSTON-SALEM (AP) — For his final day of campaigning for Saturday's runoff Democratic primary, Sen. B. Everett Jordan planned a morning of handshaking in Winston-Salem and Burlington industrial plants today. Then he will return to his Raleigh campaign headquarters.

In the afternoon, the senator was scheduled to attend the funeral of Mrs. Jackie Wharton, one of the three persons killed in Monday's shooting spree by a gunman in a Raleigh shopping center where Jordan had made an unannounced campaign appearance.

Jordan has campaigned his hardest yet in his final week of a battle to come from behind

Youth And Adult Rally Tonight

AYDEN — A youth and adult rally will be held tonight at 7:30 at the Community Baptist Church here.

The gospel film "Narciso" will be shown during the evening. The setting of the film was Mexico.

Pastor Stanley E. Wingard and the church membership extends an invitation to the public to attend.

and beat Congressman Nick Galifianakis in the runoff. Galifianakis led Jordan by more than 40,000 votes in the May 6 first primary, and came within 1,000 votes of winning a majority over the senator, who has served 14 years.

Thursday, Jordan received another last-minute endorsement from Sen. Sam Ervin, a fellow democrat.

Galifianakis had hinted just prior to the first primary that Ervin was backing him, but Ervin then endorsed Jordan.

The 75-year-old Jordan has traveled from the coast to the mountains this week replying to a variety of charges by Galifianakis, making a few of his own, and again stressing his seniority as the main reason he should be returned for another six-year term.

One new issue he brought out during the week was his support of George Wallace should the Alabama governor win the Democratic presidential nomination. But he also courted black voters during the past few days in an apparent attempt to smooth over a strong antibusing statement he made earlier in the week.

On Thursday, for instance, Jordan boasted of his cosponsorship of a 1971 bill to find a

cure for sickle-cell anemia, a disease that accets blacks almost exclusively. Galifianakis, he said, had not bothered to vote, but the record also shows the bill had no opposition in the House.

The senator also continued to work harder on his campaign organization, especially in urban areas where he lost badly in the first primary.

Police said the Cow Palace threat might have been associated with the fact Sen. Humphrey visited a televised auction benefit there for about 30 minutes during the evening.

Police said the Cow Palace threat might have been associated with the fact Sen. Humphrey visited a televised auction benefit there for about 30 minutes during the evening.

Police said the Cow Palace threat might have been associated with the fact Sen. Humphrey visited a televised auction benefit there for about 30 minutes during the evening.

Police said the Cow Palace threat might have been associated with the fact Sen. Humphrey visited a televised auction benefit there for about 30 minutes during the evening.

Police said the Cow Palace threat might have been associated with the fact Sen. Humphrey visited a televised auction benefit there for about 30 minutes during the evening.

Police said the Cow Palace threat might have been associated with the fact Sen. Humphrey visited a televised auction benefit there for about 30 minutes during the evening.

Police said the Cow Palace threat might have been associated with the fact Sen. Humphrey visited a televised auction benefit there for about 30 minutes during the evening.

Police said the Cow Palace threat might have been associated with the fact Sen. Humphrey visited a televised auction benefit there for about 30 minutes during the evening.

Police said the Cow Palace threat might have been associated with the fact Sen. Humphrey visited a televised auction benefit there for about 30 minutes during the evening.

Police said the Cow Palace threat might have been associated with the fact Sen. Humphrey visited a televised auction benefit there for about 30 minutes during the evening.

Police said the Cow Palace threat might have been associated with the fact Sen. Humphrey visited a televised auction benefit there for about 30 minutes during the evening.

Police said the Cow Palace threat might have been associated with the fact Sen. Humphrey visited a televised auction benefit there for about 30 minutes during the evening.

Police said the Cow Palace threat might have been associated with the fact Sen. Humphrey visited a televised auction benefit there for about 30 minutes during the evening.

Police said the Cow Palace threat might have been associated with the fact Sen. Humphrey visited a televised auction benefit there for about 30 minutes during the evening.

Police said the Cow Palace threat might have been associated with the fact Sen. Humphrey visited a televised auction benefit there for about 30 minutes during the evening.

Police said the Cow Palace threat might have been associated with the fact Sen. Humphrey visited a televised auction benefit there for about 30 minutes during the evening.

Police said the Cow Palace threat might have been associated with the fact Sen. Humphrey visited a televised auction benefit there for about 30 minutes during the evening.

Police said the Cow Palace threat might have been associated with the fact Sen. Humphrey visited a televised auction benefit there for about 30 minutes during the evening.

Police said the Cow Palace threat might have been associated with the fact Sen. Humphrey visited a televised auction benefit there for about 30 minutes during the evening.

Police said the Cow Palace threat might have been associated with the fact Sen. Humphrey visited a televised auction benefit there for about 30 minutes during the evening.

Police said the Cow Palace threat might have been associated with the fact Sen. Humphrey visited a televised auction benefit there for about 30 minutes during the evening.

Police said the Cow Palace threat might have been associated with the fact Sen. Humphrey visited a televised auction benefit there for about 30 minutes during the evening.

Police said the Cow Palace threat might have been associated with the fact Sen. Humphrey visited a televised auction benefit there for about 30 minutes during the evening.

Police said the Cow Palace threat might have been associated with the fact Sen. Humphrey visited a televised auction benefit there for about 30 minutes during the evening.

Police said the Cow Palace threat might have been associated with the fact Sen. Humphrey visited a televised auction benefit there for about 30 minutes during the evening.

Police said the Cow Palace threat might have been associated with the fact Sen. Humphrey visited a televised auction benefit there for about 30 minutes during the evening.

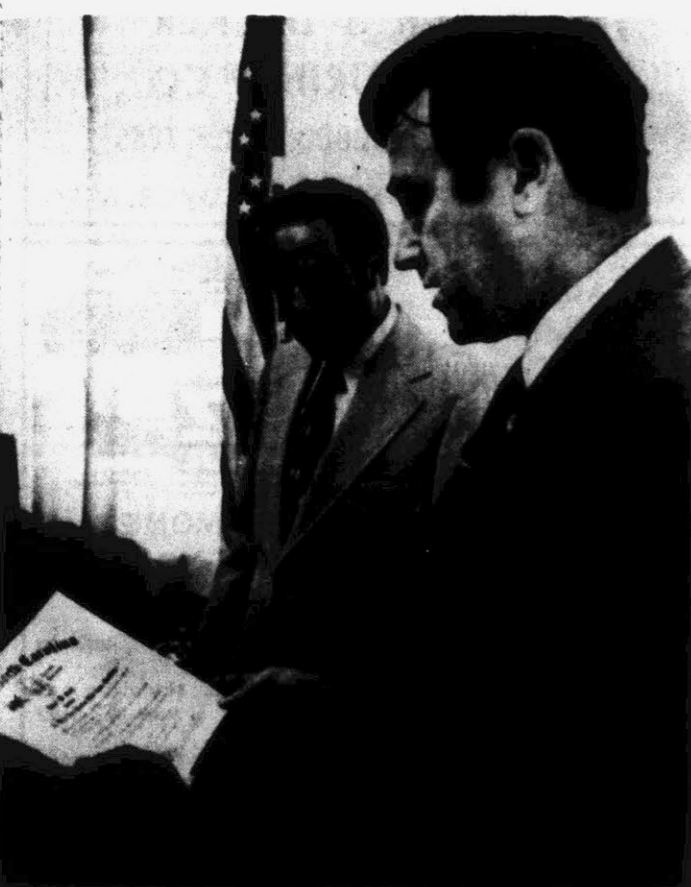

YOUTH COMMISSIONER — Gov. Bob Scott (right) presided Thursday at the swearing in of James M. Paige (left) as the new commissioner of North Carolina's Department of Youth Development. Paige, a former FBI agent, is the first Negro to head a state department in modern times. (AP Wirephoto)

NOTICE

The Pitt County Board of Equalization and Review will meet in the Commissioner's Room in the Pitt County Courthouse Monday, June 5, 1972 at 2:00 P. M. This is for the purpose of reviewing the assessed value placed on property for the first time in 1972 in all townships within the county.

You may examine your appraisal on file in the office of the Tax Supervisor prior to the meeting of the board. If, after your examination, you feel the value placed on your property is not comparable with the value of similar property in the county, you may appear before the Board of Equalization and Review and present your case.

The board expects to complete its hearings and adjourn July 3, 1972. In the event of a later adjournment, notice to that effect will be published in this paper.

Very truly yours,
R. S. Moyer
Tax Supervisor

Fact . . . Fantasy . . . Apathy

On May 6, only 15,500 of 31,000 registered voters in Pitt County went to the polls. This is a fact and shows apathy to the issues that we should all be interested in. The results of the elections this year will directly affect each of us for the next four years! This is our chance to have some say in our future! We all have the tendency to criticize elected officials. Why not earn your right to criticize by voting in the June 3rd primary runoff? Vote for the candidate of your choice. I have chosen my candidates and I plan to vote for them.

Although Pat Taylor ran second in the May primary, I plan to vote for him on June 3rd because I feel he has given us facts and not fantasy on the major issues that are important to those of us who live in the East.

Just what are some of the issues and the stands taken by the candidates?

1. Taxation

Bowles has come out with a statement of absolutely no increase in taxes! He states that he can get all the money necessary for a sound, progressive program by present surpluses and by eliminating waste in government. We all realize that every government has wasteful spending and if it were possible to round it all up he might even be able to get the major part of his program through without increased taxes. But to say absolutely no taxes is pure fantasy in my way of thinking.

Taylor, on the other hand, approaches the problem realistically! He does not advocate new taxes, but does say if new revenue is needed he will get it by raising the taxes of those who make over \$20,000 a year and the corporation tax. I feel this is essential. I fall in the corporation category, and I still believe it to be the best approach. Pat Taylor advocates the removal of the tax on those people making less than \$5,000 a year. With out present cost of living, Pat Taylor's approach is fair and it is realistic.

2. Education

Skipper Bowles has put a great deal of emphasis on development of community colleges and technical institutes. Pat Taylor has been instrumental in helping develop our already existing community college and technical institute system. We all feel these programs are vital. To me, Bowles' joining the band wagon is like a "Johnny come lately."

3. Medical Care for the Citizens of North Carolina

Skipper Bowles recommends formation of area and regional medical clinics. This would be an improvement if we could staff them. However, the real problem is a shortage of local medical doctors (family doctors)! It boils down to the proven fact that we need another medical school! Bowles says let the Board of Higher Education make this decision. For the past several years we have seen the delaying tactics used by this board. Their present plan of multiple 1 year medical schools is quite unrealistic and costs by far more than a new medical school would. The legislature has already voted for a medical school at East Carolina University. Bowles does not endorse this. Pat Taylor does endorse it. Let us elect Pat Taylor and get on with it!

We need a School of Veterinary medicine in this state. Put it at Charlotte or in Raleigh.

4. Highways

Skipper Bowles hit it on the head when he said we in the East have been treated like stepchildren as far as highways are concerned. But what about his solution? He does not offer us any new major highways! He simply states he will guarantee us a fair shake! Haven't we all seen enough of Piedmont's fair shakes?

Pat Taylor advocates a four lane East-West highway to the coast and a four lane coastal highway. Let's give him a chance. If he doesn't produce, then let us ask the Republicans to do the job!

SUMMARY

Pat Taylor has pledged his support to help us develop in all fields here in the East! Skipper Bowles has made no offers of help to the East. During his 5 years as a legislator he never initially supported us on any major issue. He has made no indication through discussing the issues that he will do so if he is elected to head our state.

I certainly know that many of you will disagree with my viewpoint. That is your right and privilege. I only hope that I have made all of you stop and think. Get rid of voter apathy! Go to the polls and vote for the man of your choice—But vote!

Everybody loves to be a winner. . . I hate to have the East a perennial loser!

I say vote! I plan to vote for Pat Taylor.

Sincerely,
Ray D. Minges, M.D.

Getting Married?

Come to Capital Mobile Homes and see how you can save on your own mobile home!

Ask For
GARY SINGLETON
Capital Mobile Homes
2720 S. Memorial Dr.
Greenville, N.C.



HEIL

The best in heating and cooling equipment. Take advantage of our early season air conditioning prices.

See
Quality Heating & Air Conditioning Co.
2001 Greenville Blvd.
PHONE 752-3042

Graduation At Day Center

The Meadowbrook Day Care Center will have its annual graduation exercises Sunday at 5 p.m. at the center. Parents are asked to have their children at the center by 4:30 p.m.

Center Offering Shorthand Class

Moyewood Social Service Center has scheduled a shorthand class to begin Monday at 7 p.m. The class time will be Monday and Wednesday evening from 7 to 8:30. Anyone interested in registering may call 758-5010 or visit the Center at 1710 W. Third Street.

MEET SUNDAY

The Star of Zion Ushers will meet Sunday in the educational department of the church immediately following the morning services. Important business will be discussed.

Reflector Classified Ads Work For You

Dial
752-6166

Public Notices

NOTICE In The General Court of Justice Superior Court Division Before The Clerk

North Carolina
Pitt County
The undersigned, having this day qualified as Administrator of the Estate of J. L. Gurganus, Sr., deceased, this is to notify all persons, firms, and corporations having claims against said estate to present them to the undersigned or their attorneys, Everett & Cheatham, P.O. Box 621, Bethel, N.C., on or before the 12th day of November, 1972, or this notice will be deemed in full of their recovery. All persons indebted to said estate will please make immediate payment to the undersigned. This 9th day of May, 1972.
J. L. GURGANUS, JR.
SALLIE G. WILLIAMSON
Bethel, N.C.
Administrators of the Estate of J. L. Gurganus, Sr.
May 12, 19, 26, June 2

NOTICE TO CREDITORS North Carolina

Pitt County
The undersigned, having qualified as Executor of the Estate of Minnie Winslow Reed, late of Pitt County, North Carolina, this is to notify all persons having claims against said estate to present them to the undersigned on or before the 25th day of November, 1972, or this notice will be deemed in full of their recovery. All persons indebted to said estate will please make immediate payment. This 25th day of May, 1972.
CATHERINE REED JOLLY
EXECUTRIX OF THE ESTATE OF MINNIE WINSLOW REED, DECEASED.
POST OFFICE DRAWER 99
GREENVILLE, N.C. NORTH CAROLINA 27834
JAMES SPEIGHT, WATSON AND BREWER, ATTORNEYS
May 26, June 2, 9, 16

NOTICE OF PUBLIC HEARING ON PROPOSAL TO CLOSE AND ABANDON CERTAIN DEDICATED AND OPENED STREETS

Pursuant to Sub Section 17, Section 9, Chapter 153 of the General Statutes of North Carolina, notice is hereby given that the City Council of the City of Greenville, North Carolina, will hold a public hearing in the Council Chamber of the Municipal Building in the City of Greenville, North Carolina, on Thursday, June 8, 1972, at 8:00 P.M. to consider a request for the closing and abandonment of those certain streets and opened streets within the City of Greenville which are described as follows:
1. Mill Street from Wade Street, easterly to Center Street.
2. Factory Street from Ridgeway Street, easterly to Center Street.
3. Center Street from Broad Street, southerly to Railroad Street.
4. Cross Street from Broad Street, southerly to Railroad Street.
5. Wade Street from Short Street, northerly to the Project boundary line.
Any persons interested in the proposed closing and abandonment of the above streets are requested to be present at the time and place afforded when they will be afforded an opportunity to be heard.
BY ORDER OF THE CITY COUNCIL
W. N. MOORE
City Clerk
David E. Reid, Jr.
City Attorney
May 19, 26, June 2, 7

NOTICE OF SALE

North Carolina
Pitt County
Under and by virtue of the power of sale contained in a certain deed of trust executed by WOODROW HULON and wife, HELEN JEAN HULON, to CLAUDE E. POPE, Trustee, dated 12th day of October, 1970, and recorded in Book 39 at page 302, in the Office of the Register of Deeds of Pitt County, and under and by virtue of the authority vested in the undersigned as substituted trustee by an instrument of writing dated the 1st day of May, 1972, and recorded in Book 40 at page 45 in the Office of the Register of Deeds of Pitt County, the terms thereof subject to foreclosure, and the holder of the indebtedness thereby secured having demanded a foreclosure thereof for the purpose of satisfying said indebtedness, the undersigned substituted trustee will offer for sale at public auction to the highest bidder for cash
AT THE COURTHOUSE DOOR
IN GREENVILLE,
NORTH CAROLINA,
AT 11:30 A.M., ON THE
20TH DAY OF JUNE, 1972
the land conveyed in and by deed of trust, the same lying and being in Grimesland Township, County of Pitt, State of North Carolina, and more particularly described as follows:
KNOWN AS 101 CHIPAWAY DRIVE
Being numbered and designated as Lot 1 Block B as shown on map of Section II of SHERWOOD GREENE by Helms and Associates, C. E., dated April 10, 1970, and of record in Map Book 20, pages 29 and 29A, Pitt County Registry, to which reference is hereby made for greater certainty of description, subject, however, to drainage easement shown on map above referred to.
This conveyance is made subject to the restrictions as to use and occupancy set forth in that certain declaration extending to Mark I, Inc., and registered in Book E 39, page 339, Pitt County Registry.
The above property is to be sold subject to unpaid taxes and assessments, if any.
This 17th day of May, 1972.
ROBERT R. BROWNING
SUBSTITUTED TRUSTEE
Owens and Browning
Attorneys at Law
P. O. Box 302
Greenville, N.C. 27834
May 26, June 2, 9, 16

NOTICE TO CREDITORS In The General Court of Justice Superior Court Division Before The Clerk

North Carolina
County of Pitt
IN THE MATTER OF THE ESTATE OF (MRS.) ALMETA ROGERS CHERRY
Having qualified as Executor of the Estate of (Mrs.) Almeta Rogers Cherry, late of Pitt County, North Carolina, this is to notify all persons having claims against the estate of said Almeta Rogers Cherry to present them to the undersigned or their attorneys, Everett & Cheatham, P.O. Box 621, Bethel, N.C., on or before the 12th day of November, 1972, or this notice will be deemed in full of their recovery. All persons indebted to said estate will please make immediate payment. This 9th day of May, 1972.
DR. CHARLES M. CHERRY
419 N. 7th Street
Wilmington, N.C.
Executor of the Estate of (Mrs.) Almeta Rogers Cherry
Deceased.
June 2, 9, 16, 23

GRADUATION SPECIAL

Free yourself this summer
SL 125 Regularly \$589.00
This week only \$499.00
plus tax
Your choice of blue, gold, or green.
Stan's Sports Center
1025 S. Evans Street
Greenville, NC

Autos For Sale

BUICK WILDCAT, 1967, excellent shape, air condition. Must sell. Call 758-4927 or 746-4530.
CHRYSLER NEW YORKER, 1966, 4 door sedan, full power, excellent condition. 52,000 miles, by owner. Call 756-0970.
CAMARO 327, 1968 automatic, air, power steering, stereo, tape, very good condition. Call 758-2105 after 3 p.m.
CHEVROLET 1965 2 door, Impala Sport coupe A-1 condition. 8550. Call 758-1386 after 5 p.m.
CHEVY 1956, 2 door sedan, looks original. V-8, headers. \$1300 invested, first reasonable offer. Call 752-2612.
1969 ELECTRA 225, Buick, Wholesale \$500. Below car lot price. Full power, two door hardtop, good shape. \$2350. Call Carl Darden, 758-1183.
CORVAIR, 1966 GOOD body, tires and motor, four in the floor. \$295. Call 756-4614 after 6 p.m.
FORD FAIRLANE, 1958 4 door, V-8 125 or Ford Galaxie 500 1968, V-8, 4 door, air condition, \$1300. Sale one only, by owner. 756-0275.
1968 GRAND PRIX, loaded, excellent condition, new tires. \$1575, 756-0692 after 5 p.m.
GRAND PRIX, 1965 2 door hardtop, new tires, real clean. \$495. Call 756-3992.

1965 Chevelle

4 dr. Sedan, 6 cylinder, automatic. \$475

1964 Fairlane

2 dr. hardtop, V-8, automatic. \$475

1968 Chevelle

2 dr. hardtop, V-8, automatic, with air condition. \$1250

1970 Ford Ranch Wagen

390 automatic, with air \$1550

1968 Ford F-100 Pickup

V-8, straight shift. \$1350

CRISP AUTO SALVAGE INC.

North Green St.
752-2572

IMPALA CUSTOM COUPE, 1970, white, black top, black interior, 350 turbo hydramatic, power steering, power disc brakes, factory air, AM-FM, \$2695. Pinner-White, Ayden, 746-3141.
IMPALA, 1965, two door hardtop, 4 speed, can be seen at Winn Dixie, 10th St., Greenville.
MONTE CARLO, 1971, full power with air condition, steel silver, black top. 746-6566.
PONTIAC LE MANS Coupe, 1967, white with black vinyl top, extra clean. \$1250. Holt Oldsmobile/Datsun.
OLDSMOBILE 1966 98, all extras. Call 752-5307 between 7.5, 756-2090 after 6 p.m.
OPEL 1971 GT, 8,000 miles, air condition with all the extras, take up payments. Must sell. Call 756-0747.
OPEL KADETT, 1968, excellent condition, yellow, black interior, \$850. Must sell. Call 758-5882 after 6 p.m.
HASTINGS FORD has daily rentals at reasonable prices. Call 758-0114.
TORINO, TWO DOOR, hardtop, 1970, 351, 2 V engine, cruise o-matic, power steering, radio, air condition, tinted glass, WSW, vinyl interior. F and D Motors, Bethel, 825-4451.

72 DATSUN

1/2 Ton Pick-up
AMERICA'S NO. 1
SELLING ECONOMY
PICK-UP TRUCK
Holt
Olds-Datsun
101 Hooker Road
756-3115
Where Service Comes First

VOLKSWAGEN 1968 Beetle

Excellent shape. New tires and clutch. \$1150. Call 758-4698.

KINGSWOOD 1969 Station wagon

V-8 auto, power steering, air. Downtown Motors, Ayden, 746-6892.

FOR SALE: 1971 Fleetwood Cadillac

Brougham, fully loaded; over \$10,000 newly. Approximately 11,000 miles. Contact 919-946-6521, Washington, North Carolina.

Cycles for Sale

BSA 1970 650. Must sell. 752-4236.
1971 HONDA SL 175. Best offer. Call 756-3478 after 6 P.M.

HONDA 175-ROAD bike

Excellent condition with full chrome treatment. Call 756-0980 after 4 p.m.

1970 CB 450 HONDA

fully equipped, \$750. Call 758-4700 day, 758-1709 night.

1964 BSA 500

1967 engine, \$275. Can be seen 1804 East Third, Greenville, N.C.

Free yourself this summer

SL 125 Regularly \$589.00
This week only \$499.00
plus tax
Your choice of blue, gold, or green.

Autos For Sale

BUICK 1971 ELECTRA LIMITED, fully equipped, many extras, beautiful condition. Priced to sell. 756-2904.

AUTOMOTIVE

Autos For Sale

VOLKSWAGEN BUS station wagon, 1968 nine passenger, 2211 series. \$1895. Pinner-White, Ayden, 746-3141.
V-6 FWP JEEPSTER convertible Rolly Trailer. Complete electric up & down drive. Approximately 1/2 cost. Call day 752-2507. Home 752-7404.

THE BIGGEST SELLING SMALL CAR IN EUROPE

BROWN-WOOD

Pontiac-Cadillac-Fiat
Dickinson Ave 752-7111

Trucks for Sale

FORD PICKUP, 1964 1/2 ton, long body. \$750. Call 756-1444.
1970 EL CAMINO, 15,700 miles, power steering, brakes, air, vinyl roof, one owner. Call 752-3023 after 6 p.m.

BOATS & EQUIPMENT

1971 14 FT. FIBERGLASS boat, 18 h.p. Evinrude motor, Cox trailer. 756-7272.
1966 FIBERGLASS 16' boat with 40 h.p. Evinrude, Cox trailer. Priced to sell. Call 752-5307 between 7.5, 756-2090 after 6 p.m.

DAY NURSERY

OPENING FOR TWO or three children, small or large. Call 756-7900.

DOGS & PETS

TWO FEMALE BLACK AKC REGISTERED POODLES. Call Joe, 752-6797.
WEINERANER PUPS, AKC champion line from Mid west, solid silver gray, show prospect, all shots and wormed, \$85 and up. J. W. Woodard, Raelord, 875-3871.

BRITANNY SPANIEL PUPS, AKC registered, from good quality hunting stock, excellent bloodline, 7 weeks old. \$30. Griffon 524-5442.

FEMALE GERMAN POINTER bird dog, hunted two seasons, well broke. Excellent retriever. \$150. Call 752-5031 day, 756-1667 night.

AKC LAB PUPS, will trade for bicycle, pony or outboard motor, will deliver. 756-0882.

SEALPOINT SIAMESE KITTENS for sale, one chocolate point. Call 758-0551. Call now 758-2444, or write Mrs. Willa M. Woolen, Box 215 Leon Dr., Greenville, NC 27834.

EMPLOYMENT

NURSERY AND KINDERGARDEN teacher, full time. Apply at Little University, Farmville, 753-5681.

WANTED: LEGAL SECRETARY. Send written resume to "Legal Secretary", P.O. Box 1967, Greenville.

AVON

AVON CAN HELP you earn extra cash for summer vacation, new clothes - or your heart's desire! Work spare time near home. Call now 758-2444, or write Mrs. Willa M. Woolen, Box 215 Leon Dr., Greenville, NC 27834.

BOOKKEEPER-General Office Worker with some knowledge of bookkeeping, will train. Call Cox Armature Works, 756-5193 for application.

NURSERY AND KINDERGARDEN

teacher, full time. Apply at Little University, 315 E. 10th St., 752-7148.

Male Help Wanted

TRACTOR TRAILER TRAINERS NEEDED. You can now train to become an over the road driver or city driver. Excellent earnings after short training on our trucks with our driver instructors to help you. For application and interview, call 919-484-3975, or write School Safety Division, United States, Inc., 325 Hay Street, Fayetteville, NC, 28307. Approved for V.A. Benefits. Placement assistance available. Over 700 transportation companies have hired our graduates.

MANAGER AND ASSISTANT manager for the Happy Store a convenient food store opening soon in Farmville, Prefer Farmville. Native 21.30 willing to work long hours. Starting salary plus per centage of profits. For right man. Interviews by appointment only. Call Bill Ippock, The Happy Store, Greenville, 752-5933.

WANTED TV TECHNICIAN. Must have experience, good benefits. Apply at once. Farmville Furniture Company, Farmville, N.C.

SHEET ROCK FINISHERS, regular work, \$4.00 an hour or piece work. Apply in person, Ayden Housing Project or call Towne House Motel, ask for James Autry.

MILKING MACHINE OPERATOR. See Charles McLawhorn, Rt. 1, B.OX 222, Winterville, 756-2017.

SHIFT DYER. One to two years experience in dyeing. Contact Personnel Manager, Glenoit Mills, Tarboro. An Equal Opportunity Employer.

CRISP AUTO SALVAGE

Phone 752-2572 N. Green St.
Back of Respass Barbecue

See our new line of Aluminum Jon Boats. Over 30 in stock, and our new line of Fiber Glass boats, Cruisers Inc.

McCulloch

Chain Saws
CLARK & CO.
3008 Memorial Drive 756-2557

TAKE UP PAYMENTS. 1972 Color T.V., 23" screen, 42" walnut cabinet, only two months old, still under warranty, \$589.95 pay only \$327. Time payments United Freight Co. 2904 E. 10th St., 752-4053.

TIRES, WHOLESALE TO everyone. \$50.13, \$17, 735-14-519, \$25-14-521, \$78-14-523, \$178-14-526. Many others in stock. All taxes excluded. United Freight Co., 2904 E. 10th St., 752-4053.

STEREOS. (10) new 1972 console stereos, AM-FM, deluxe record changer, jock for 8 track tape, 8 speakers, 60" long, Regular \$419.95, now \$179. United Freight Co., 2904 E. 10th St., 752-4053.

COLOR T.V. COMBINATION, (5) new 1972 Color T.V. combination, AM-FM deluxe record changer, RCA, highlight tube. Regular \$799.95, now \$497. All items fully warranted. United Freight, 2904 E. 10th St., Greenville, 752-4053.

Great Northern Development Co.

P. O. Box 98
New Bern, NC 28560

PART-TIME SALEMAN for E. C. U. student only. May lead to a career. Call 752-4080 Mr. B. L. Hunt.

CARPENTER FOREMAN WANTED. Call 758-4733 between 8-4.

MARRIED MAN, 23-35 for field sales. Not door to door selling. Must be honest, ambitious, have self-discipline, integrity, with desire to progress. Rewarding career. Permanent. Sales experience helpful but not necessary. Training at company's expense. Salary or commission. For confidential interview call BELTONE, 758-5121.

Male Help Wanted

MOBILE HOME REPAIRMAN experience in all phases of mobile home repairs. No calls. See Dan Sinection, Capital Mobile Homes.

SALESMAN WANTED. Ideal career opportunity for one salesman to work out of Greenville, N.C. No overnight travel, no sales experience necessary. Will train the right man, ideal working conditions with good salary and yearly bonus. This could be what you are looking for! Write giving past work experience to "Sales", P.O. Box 3278, Fayetteville, N.C. 28302.

Male-Female Help

WANTED MAN OR WOMAN over 25 to sell and collect insurance. Free life insurance & hospitalization. Starting salary \$125 per week. Write Box 652 Greenville, NC.

DUNHILL
The Job Finders
758-2107.

WE HAVE THE JOB THAT'S RIGHT FOR YOU... NOW

Choose your skill and learn it while you serve your country. Benefits include: guaranteed promotion, 30 days paid vacation, free travel, job security, and free medical care. Contact your Air Force Recruiter. Call 752-4296.

Work Wanted

LAWN MOWING SERVICE. Neil Elks, 752-5401.

MALE HIGH SCHOOL teacher seeks summer employment. Call 825-3481.

WHITE LADY WANTS work in home nursing the sick or age, good experience. Call 752-4357.

EXPERIENCED TEACHER and tutor desires elementary students for summer individualized tutoring. Call 756-6472 after 4 p.m.

FARM EQUIPMENT

Farm Machinery Auction Sale

Tuesday, June 6, at 10 a.m.
75 Farm Tractors 300 implements
Wayne Implement Auction Corporation
Goldsboro N.C.
South on HWY 117
Phone 734-4234

ONE B-N FORD with Sherman transmission

Call 746-6836.

EQUIPMENT FOR SALE

Blue Squeeze-Ezz, 3 point nitrogen applicator. \$300.

3-Silent Flame Harvesters, \$300-\$400.

1-Piedmont Hawk Looper excellent condition. \$1,050.

International 2 ton grain type truck, good condition. \$650.

Call 756-4126

FOR SALE

Miscellaneous for Sale

COMPLETE GRILL EQUIPMENT and stock in country store for sale, includes cash register, scales, heater and drink boxes. Call 758-1881 or come by at Reston.

THE FINEST in wedding gifts now at The Linen Closet, 3008 E. 10th St., Greenville.

WESTINGHOUSE UPRIGHT Freezer, holds 12.1 cu. ft. or 423 pounds. Easy open door latch and built in lock. Now \$199.95, was \$249.95. Smith Electric Co., 415 Evans St., 752-2114.

MAKE HODGES HARDWARE your shooting headquarters. Complete stock of reloading equipment, bullets, primers, casings, guns, ammo and targets. Call H. L. Hodges Hardware, 752-4156.

GOCART, ELECTRIC GUITAR, Magnus cord organ. Call 756-0954.

JUST RECEIVED SHIPMENT of damaged merchandise. Great savings up to 30 per cent on Kelvinator appliances. Fisher's 752-3603.

ARC WELDER - Brand new, 110 volt - Complete with helmet and rods. \$18.95, moneyback guarantee. Free details. Write: National Electric, Box 544, I.A.B., Miami, Fla. 33148.

MOVING? CONTACT OTHER movers and men. Used but not phone. 752-4541. Let us check your rates.

TWO CARRIER AIR conditioners, 14,000 and 8,700 BTU, both for \$150. Six drawer chest for child's room, \$18. One silvertone black and white TV 19" \$50, and one Louvered front screen door \$8. Call 756-2246.

GUARANTEED engines, transmission, body parts. Free parts locating service

CRISP AUTO SALVAGE
Phone 752-2572 N. Green St.
Back of Respass Barbecue

McRoy Insurance Agency

3010-A East 10th Street
Greenville, N.C.
758-4700

LOST & FOUND

LOST: SMALL COLLIE type sheep dog, wearing red flea collar. Call 756-3679.

PRESCRIPTION EYE GLASSES wire frame lost in downtown Greenville. Call 756-4559.

MOBILE HOMES

Mobile Homes for Rent
40 x 12 THREE BEDROOMS air conditioned, small wooded lot. Family only. 752-7246.
MOBILE HOMES for rent, air conditioned with water furnished. Call 752-5362.
FOR RENT, MOBILE HOME lots. See Bruce McLawhorn, six miles east of Greenville on 264.
TWO BEDROOM mobile homes for rent. Call 756-1341.
TWO AND THREE bedroom mobile homes, air conditioned, good location. Call 752-3286 or 825-5391.

SPECIAL SUMMER RATES

2 and 3 bedrooms available, all with air condition.

PINEVIEW COURT

Call 758-3644
TWO BEDROOMS, 12 wide, air condition, Shady Knoll Trailer Park, 756-2892.

Miscellaneous for Sale

16,500 BTU AIR conditioner, \$75. Call 746-8150.
See it, To Believe!
Electric Start 8 Horse Power 30" Mower.
Now Only \$479.95

R. F. McLawhorn & Sons

1408 N. Greene St.
"We Service What We Sell"

WE UPHOLSTER ANYTHING. thousand of yards of fabric and foam cushioning. Jackson's Tire & Upholstery, Dickinson Ave., 758-3276 day or 758-1505 nights.

MOVING. MUST SELL. 3/4 bed-foam mattress, box springs, and frame never used \$50; Manous Oream \$20; Drafting supplies kit \$15; Book \$6; Computer book \$4. Call after 3:30 752-3466.

SPECIAL Executive Desks

60 X 30" beautiful walnut finish. Ideal for home or office.
Reg. Price \$143.30 Special Price \$99.50
TAFF OFFICE EQUIPMENT
569 S. Evans St. 752-2175

Carefree Summer Driving

Find the dependable firm to put your car into vacation-safe condition in today's Daily Reflector Classified Ads

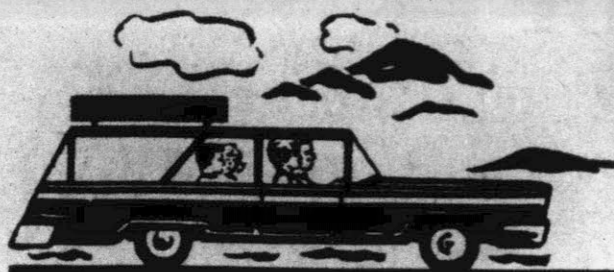

RENTALS

Apartment For Rent

OAKMONT Square Apartments
1212 Redbank Road
Telephone: 756-4151

TAR RIVER ESTATES APTS.
1, 2 & 3 Bedrooms Available
Washer - Dryer Hook-Ups
Hotpoint Equipped 752-4225

REDWOOD APARTMENTS, one bedroom furnished, heat, air condition and water furnished. Call 752-6137 or night 756-3465.

TWO BEDROOM FURNISHED apartment, married couple, no pets. \$92.704 E. Third St., 752-4717.

ONE BED ROOM apartments for rent air condition, water furnished near college campus. Will rent for summer session. Call day 752-6137 or night 756-3454.

OAKMONT SQUARE Apartments

- 2-bedroom,
- electric heat,
- 6-closets, fully carpeted, disposal, dishwasher
- club house, swimming pool,
- laundry facilities.

Near Shopping Centers, schools, churches & university.

1212 Redbanks Rd.
Tel.: 756-4151

EQUIPPED WITH
Hotpoint
MAJOR APPLIANCES

2 Available For Lease
June 15

CLASSIFIED DISPLAY

FULL LINE OF CHRYSLER BOATS, MOTORS, ACCESSORIES
We Honor Charge Cards

GASKINS SUPPLY
Grimestand 752-5374

105 Trade St. Greenville, N.C. 27834

We Hang Drapes Install Hardware

K-1 VALUES DRAPERY SHOP

Custom Drapes - Bedspreads
Cornices - Table Cloths

HOURS: Mon. - Sat. 9:30 a.m. to 5:30 p.m.
Phone Number 756-6611

PRODUCTION SUPERVISOR
Wanted Immediately: Experienced Production Supervisor For Assembly Department. We Are Looking For A Man With Several Years Experience Who Would Like To Grow With A Progressive Company. Production Facilities Will be Moved To A Completely New Plant In Greenville In September. Be One Of The First To Get In On The Opportunities Offered By The Opening Of A New Plant.

APPLY:
NATIONAL BOAT WORKS, INC.
714 ALBEMARLE AVENUE
GREENVILLE, N.C.
752-2111

NICE FARM FOR SALE
LENOIR COUNTY
Suitable for Housing Project, Industrial Development, and Farming. Located near Railroad and Highway. Write P.O. Box 666, Grifton, N.C.

DOLPHIN & DORADO
VOTED MOST BEAUTIFUL MOBILE HOMES IN U.S.A.
Can Be Seen At
CAPITAL MOBILE HOMES
2720 S. Memorial Dr.
756-6244

PHILIP R. ROBERSON
PROFESSIONAL PAINTING SERVICE
INTERIOR & EXTERIOR ALSO ROOF TOP WORK
FREE ESTIMATES ALL WORK GUARANTEED

308 E. Church St. Farmville, NC 753-5077
Call before 8:00 a.m. or after 5:00 p.m.

Apartment For Rent

ONE BEDROOM APARTMENT, furnished or unfurnished. Call 756-3864

TWO BEDROOM DUPLEX apartment, wall-to-wall carpet, 507 W. 3rd St., Ayden. Call 527-0711 Kinston.

STADIUM APARTMENTS, located on 14th St., between men's dormitory and coliseum. Modern, air conditioned, walking distance to entire campus. 752-5700, 756-4671.

MIDTOWNE APARTMENTS, WINTERVILLE one bedroom, furnished. Turcotte Realty, 752-3881.

COLLEGE VIEW APARTMENTS, two bedrooms, unfurnished. Turcotte Realty, 752-3881.

TWO BEDROOM FURNISHED apartment, air condition, private entrance. Call 756-1330.

FURNISHED, NEAR DOWNTOWN and university, couple only. Mrs. D.M. Clark, 752-3447.

Stratford Arms Apts., 1900 S. Charles St. An exclusive community designed to provide the ultimate in gracious living. Modern 1, 2 and 3 bedroom garden apartments and 2 bedroom Townhouses. Furnished or unfurnished. 756-4800.

CHALET APARTMENTS, Winterville, N.C., 3 bedrooms, fully carpeted, stove and refrigerator furnished. Call 746-4310.

2400 E. 10th FURNISHED, suitable for 4 boys, Available June 1. Call 752-4661 or 756-4013.

CLASSIFIED DISPLAY

EQUIPPED WITH
CRAWFORD'S FRESH VEGETABLES
Garden Peas, Collards, Cabbage, and Others in Season.

Located 6 miles west of Greenville on Farmville Hwy. Watch for the sign on the right.

Call 756-2434

RENTALS

Apartment For Rent

APARTMENTS
1 & 2 bedroom furnished & unfurnished. Contact M.E. Sutton or C. L. Thigpen, Jr. Call 752-6121

PLUSH COUNTRY CLUB apartments. Two bedrooms, wall-to-wall carpet, draperies, kitchen appliance and water. Rent furnished or unfurnished. Call 756-5234.

AYDEN, N. C., TWO bedroom apartment, stove and refrigerator furnished carpeted, available June 1. Call 746-6116 day, 746-3308 night.

RENTALS

Houses for Rent

TWO BEDROOM HOUSE in Ayden, \$75. Call 752-3373.

FOUR ROOM FURNISHED house with air condition. 115 W. Redman Ave., Greenville.

REAL ESTATE

Houses for Rent

FOR RENT WITH option to buy. Five bedrooms, living room, dining room, den, kitchen, three baths, three fireplaces, fully carpeted, custom drapes, central heat, two car garage, recreation, carport, two lots. Bethel, 825-2331 after 8 p.m.

NEW THREE BEDROOM, two bath brick bungalow, country, Farmville area, 12 miles from Greenville, \$150 per month. 753-2425.

TWO BEDROOM UNFURNISHED house. Available July 1, completely carpeted, central air, two blocks from college. Write "House", P. O. Box 1967, Greenville.

THREE BEDROOM HOUSE, 404 S. Library St., unfurnished or furnished, available July 1. Can be seen by appointment call 752-5396 through June 9.

THREE BEDROOM FURNISHED house on Pachtosus Hwy. Call 756-2861 or 756-3225.

EIGHT ROOM HOUSE on Pachtosus Hwy, central heat, air, carpeting, large private lot. Call 756-2671.

USED CAR

5-71 Galaxie 500's
All have air condition, all full power.
Priced at \$2450

70 Torino GT Full power, automatic. \$2395

70 Country Squire Wagon 10 passenger, full power, plus air condition. \$2995

70 LTD 4 dr. hardtop, full power with air. \$1895

71 Mach 1 Automatic, full power. \$2795

69 Galaxie 500 4 dr. Sedan, full power, plus air. \$1495

72 Vega Automatic, full power, air. 600 miles. Only \$2495

71 Monte Carlo Full power, plus air, AM-FM stereo tape. \$3695

71 Electra 225 4 dr. hardtop, full power, plus air condition. \$4695

69 Electra 225 Limited full power, plus air condition, local one owner. \$3095

69 Elecetra 225 4 dr. hardtop, full power, plus air condition. \$2795

68 Electra 225 2 dr. hardtop, full power, plus air. \$1895

70 Buick Skylark Convertible Full power, with air, bucket seat console. \$2695

69 Olds Cutlass Bucket seats, full power, plus air. \$2095

72 Ford Sports Custom 1/2 Ton Pick-Up Explore package, V-8, New. \$2995

72 Ford Ranger V-8, automatic, power steering. \$2995

70 Chevrolet 1/2 Ton Custom \$2095

70 Datsun One local owner. \$1695

61 GMC \$395

Hours:
8:00 A.M. UNTIL 8:00 P.M. Monday-Friday
8:00 A.M. UNTIL 6:00 P.M. Saturday

UNIVERSITY AUTO SALES
103 E. Greenville Blvd. 756-5608

RENTALS

Apartment For Rent

ONE BEDROOM APARTMENT, furnished or unfurnished. Call 756-3864

TWO BEDROOM DUPLEX apartment, wall-to-wall carpet, 507 W. 3rd St., Ayden. Call 527-0711 Kinston.

STADIUM APARTMENTS, located on 14th St., between men's dormitory and coliseum. Modern, air conditioned, walking distance to entire campus. 752-5700, 756-4671.

MIDTOWNE APARTMENTS, WINTERVILLE one bedroom, furnished. Turcotte Realty, 752-3881.

COLLEGE VIEW APARTMENTS, two bedrooms, unfurnished. Turcotte Realty, 752-3881.

TWO BEDROOM FURNISHED apartment, air condition, private entrance. Call 756-1330.

FURNISHED, NEAR DOWNTOWN and university, couple only. Mrs. D.M. Clark, 752-3447.

Stratford Arms Apts., 1900 S. Charles St. An exclusive community designed to provide the ultimate in gracious living. Modern 1, 2 and 3 bedroom garden apartments and 2 bedroom Townhouses. Furnished or unfurnished. 756-4800.

CHALET APARTMENTS, Winterville, N.C., 3 bedrooms, fully carpeted, stove and refrigerator furnished. Call 746-4310.

2400 E. 10th FURNISHED, suitable for 4 boys, Available June 1. Call 752-4661 or 756-4013.

CLASSIFIED DISPLAY

EQUIPPED WITH
CRAWFORD'S FRESH VEGETABLES
Garden Peas, Collards, Cabbage, and Others in Season.

Located 6 miles west of Greenville on Farmville Hwy. Watch for the sign on the right.

Call 756-2434

RENTALS

Houses for Rent

TWO BEDROOM HOUSE in Ayden, \$75. Call 752-3373.

FOUR ROOM FURNISHED house with air condition. 115 W. Redman Ave., Greenville.

GREENVILLE'S FINEST USED CAR CENTER

FREE I will personally guarantee that each car has had a complete OIL & FILTER change, plus each car will have a FULL TANK of GAS when it leaves our lot. **FREE**

Truck Dept.

1971 El Camino Green, white vinyl roof, AM-FM, loaded, air condition. \$3395

1971 Ford Pick-Up F-100 1/2 Ton, Blue, 302, V-8, step bumper, like new. \$2195

1972 Olds Cutlass Loaded plus air condition. New \$4485 Now \$3595

1970 LTD Brougham 4 dr. Sedan, green, vinyl roof, stereo tape, loaded plus air condition. \$2495

1971 Pinto Yellow, automatic, air condition, body side molding, radio. \$2295

1969 Cortina GT 4 speed, local owner, excellent condition \$1395

1970 Maverick Automatic, nice shape one owner. \$1595

1967 Pontiac GTO Gold, vinyl roof, power steering, automatic, rally wheels. \$1395

1971 Pontiac Le Mans Wagon Brown, white vinyl roof, loaded, new tires. \$3795

1971 Galaxie 500 4 dr. Sedan, loaded, plus air condition, green vinyl roof. \$2795

1970 LTD 2 dr. hardtop, white, vinyl roof loaded, plus air condition. \$2495

1972 Chevy II Nova Vinyl roof, air condition, V-8, power steering, loaded, 4,000 actual miles. \$3595

RENTALS

Apartment For Rent

ONE BEDROOM APARTMENT, furnished or unfurnished. Call 756-3864

TWO BEDROOM DUPLEX apartment, wall-to-wall carpet, 507 W. 3rd St., Ayden. Call 527-0711 Kinston.

STADIUM APARTMENTS, located on 14th St., between men's dormitory and coliseum. Modern, air conditioned, walking distance to entire campus. 752-5700, 756-4671.

MIDTOWNE APARTMENTS, WINTERVILLE one bedroom, furnished. Turcotte Realty, 752-3881.

COLLEGE VIEW APARTMENTS, two bedrooms, unfurnished. Turcotte Realty, 752-3881.

TWO BEDROOM FURNISHED apartment, air condition, private entrance. Call 756-1330.

FURNISHED, NEAR DOWNTOWN and university, couple only. Mrs. D.M. Clark, 752-3447.

Stratford Arms Apts., 1900 S. Charles St. An exclusive community designed to provide the ultimate in gracious living. Modern 1, 2 and 3 bedroom garden apartments and 2 bedroom Townhouses. Furnished or unfurnished. 756-4800.

CHALET APARTMENTS, Winterville, N.C., 3 bedrooms, fully carpeted, stove and refrigerator furnished. Call 746-4310.

2400 E. 10th FURNISHED, suitable for 4 boys, Available June 1. Call 752-4661 or 756-4013.

CLASSIFIED DISPLAY

EQUIPPED WITH
CRAWFORD'S FRESH VEGETABLES
Garden Peas, Collards, Cabbage, and Others in Season.

Located 6 miles west of Greenville on Farmville Hwy. Watch for the sign on the right.

Call 756-2434

RENTALS

Houses for Rent

TWO BEDROOM HOUSE in Ayden, \$75. Call 752-3373.

FOUR ROOM FURNISHED house with air condition. 115 W. Redman Ave., Greenville.

GLASSCOW LANE

A beautifully landscaped lot with an abundance of flowers and shrubs makes a perfect setting for this executive home. A distinctive appearance, and most tastefully decorated throughout. Four large bedrooms, 2 1/2 baths. This home has all the modern conveniences - central air conditioning, dishwasher, disposal, carpeting, drapes, and lots more. With all these extras and NO city taxes, how can you resist?

DO YOU NEED
a lot of room but don't have \$50,000. We have a two story that will fit your every need. You will find 4 bedrooms, with an oversized sunken family room. 2250 sq. ft. of heated area, central air and completely carpeted. Don't worry about the weather either because you will have a built-in garage, all for Under 40.

JEANNETTE COX AGENCY
REALTOR
Lawyer Bldg. 752-7807
Car 752-2247 Home 756-2521

RENTALS

Apartment For Rent

ONE BEDROOM APARTMENT, furnished or unfurnished. Call 756-3864

TWO BEDROOM DUPLEX apartment, wall-to-wall carpet, 507 W. 3rd St., Ayden. Call 527-0711 Kinston.

STADIUM APARTMENTS, located on 14th St., between men's dormitory and coliseum. Modern, air conditioned, walking distance to entire campus. 752-5700, 756-4671.

MIDTOWNE APARTMENTS, WINTERVILLE one bedroom, furnished. Turcotte Realty, 752-3881.

COLLEGE VIEW APARTMENTS, two bedrooms, unfurnished. Turcotte Realty, 752-3881.

TWO BEDROOM FURNISHED apartment, air condition, private entrance. Call 756-1330.

FURNISHED, NEAR DOWNTOWN and university, couple only. Mrs. D.M. Clark, 752-3447.

Stratford Arms Apts., 1900 S. Charles St. An exclusive community designed to provide the ultimate in gracious living. Modern 1, 2 and 3 bedroom garden apartments and 2 bedroom Townhouses. Furnished or unfurnished. 756-4800.

CHALET APARTMENTS, Winterville, N.C., 3 bedrooms, fully carpeted, stove and refrigerator furnished. Call 746-4310.

2400 E. 10th FURNISHED, suitable for 4 boys, Available June 1. Call 752-4661 or 756-4013.

CLASSIFIED DISPLAY

EQUIPPED WITH
CRAWFORD'S FRESH VEGETABLES
Garden Peas, Collards, Cabbage, and Others in Season.

Located 6 miles west of Greenville on Farmville Hwy. Watch for the sign on the right.

Call 756-2434

RENTALS

Houses for Rent

TWO BEDROOM HOUSE in Ayden, \$75. Call 752-3373.

FOUR ROOM FURNISHED house with air condition. 115 W. Redman Ave., Greenville.

THOMAS REALTY COMPANY PRESENTS . . .
Home Buys of the Season
CHERRY OAKS

TREAT YOURSELF
to an unusual 3 bedroom 2 1/2 bath. Fireplace, central air and all the extras. \$35,300

WE ARE ENTHUSIASTIC
about this 3 bedroom, 3 bath, shag carpet all over, fireplace, central air, 2 car garage, lots of storage. \$36,200

ROOM FOR THE FAMILY
with a 4 bedroom colonial with everything including carpet & central air. \$37,200

A BEAUTIFUL WAY
to live with this 3 bedroom, 2 1/2 baths, quiet bedroom wing, 2 car garage, central air, carpet throughout, and the master bedroom is extra special \$36,200

GLENNWOOD ACRES
YOUR OWN DUCKS
with the quiet setting, 3 bedroom, 2 baths, foyer, formal dining, breakfast room, fireplace, central air and carpet. All built-ins. \$33,500

A LOT OF HOUSE
for the money by the lake. Carpet, central air, pantry, all built-ins. \$32,000

FOR THE SMART YOUNG COUPLE
a new 3 bedroom, 1 1/2 baths, garage and lots of extras. See this \$18,000

A NEW WAY OF LIFE
for the family on a budget. 4 bedrooms, 1 1/2 baths, kitchen & family room combination, garage. New and Nicely Decorated. \$21,000

We Can Answer All Questions that you have About Real Estate.

THOMAS REALTY CO.
106 Greenville Blvd.
756-5166 Days 756-5132 Nights, Weekends
Member MLS

RENTALS

Apartment For Rent

ONE BEDROOM APARTMENT, furnished or unfurnished. Call 756-3864

TWO BEDROOM DUPLEX apartment, wall-to-wall carpet, 507 W. 3rd St., Ayden. Call 527-0711 Kinston.

STADIUM APARTMENTS, located on 14th St., between men's dormitory and coliseum. Modern, air conditioned, walking distance to entire campus. 752-5700, 756-4671.

MIDTOWNE APARTMENTS, WINTERVILLE one bedroom, furnished. Turcotte Realty, 752-3881.

COLLEGE VIEW APARTMENTS, two bedrooms, unfurnished. Turcotte Realty, 752-3881.

TWO BEDROOM FURNISHED apartment, air condition, private entrance. Call 756-1330.

FURNISHED, NEAR DOWNTOWN and university, couple only. Mrs. D.M. Clark, 752-3447.

Stratford Arms Apts., 1900 S. Charles St. An exclusive community designed to provide the ultimate in gracious living. Modern 1, 2 and 3 bedroom garden apartments and 2 bedroom Townhouses. Furnished or unfurnished. 756-4800.

CHALET APARTMENTS, Winterville, N.C., 3 bedrooms, fully carpeted, stove and refrigerator furnished. Call 746-4310.

2400 E. 10th FURNISHED, suitable for 4 boys, Available June 1. Call 752-4661 or 756-4013.

CLASSIFIED DISPLAY

EQUIPPED WITH
CRAWFORD'S FRESH VEGETABLES
Garden Peas, Collards, Cabbage, and Others in Season.

Located 6 miles west of Greenville on Farmville Hwy. Watch for the sign on the right.

Call 756-2434

RENTALS

Houses for Rent

TWO BEDROOM HOUSE in Ayden, \$75. Call 752-3373.

FOUR ROOM FURNISHED house with air condition. 115 W. Redman Ave., Greenville.

THOMAS REALTY COMPANY PRESENTS . . .
Home Buys of the Season
CHERRY OAKS

TREAT YOURSELF
to an unusual 3 bedroom 2 1/2 bath. Fireplace, central air and all the extras. \$35,300

WE ARE ENTHUSIASTIC
about this 3 bedroom, 3 bath, shag carpet all over, fireplace, central air, 2 car garage, lots of storage. \$36,200

ROOM FOR THE FAMILY
with a 4 bedroom colonial with everything including carpet & central air. \$37,200

A BEAUTIFUL WAY
to live with this 3 bedroom, 2 1/2 baths, quiet bedroom wing, 2 car garage, central air, carpet throughout, and the master bedroom is extra special \$36,200

GLENNWOOD ACRES
YOUR OWN DUCKS
with the quiet setting, 3 bedroom, 2 baths, foyer, formal dining, breakfast room, fireplace, central air and carpet. All built-ins. \$33,500

A LOT OF HOUSE
for the money by the lake. Carpet, central air, pantry, all built-ins. \$32,000

FOR THE SMART YOUNG COUPLE
a new 3 bedroom, 1 1/2 baths, garage and lots of extras. See this \$18,000

A NEW WAY OF LIFE
for the family on a budget. 4 bedrooms, 1 1/2 baths, kitchen & family room combination, garage. New and Nicely Decorated. \$21,000

We Can Answer All Questions that you have About Real Estate.

THOMAS REALTY CO.
106 Greenville Blvd.
756-5166 Days 756-5132 Nights, Weekends
Member MLS

RENTALS

Apartment For Rent

ONE BEDROOM APARTMENT, furnished or unfurnished. Call 756-3864

TWO BEDROOM DUPLEX apartment, wall-to-wall carpet, 507 W. 3rd St., Ayden. Call 527-0711 Kinston.

STADIUM APARTMENTS, located on 14th St., between men's dormitory and coliseum. Modern, air conditioned, walking distance to entire campus. 752-5700, 756-4671.

MIDTOWNE APARTMENTS, WINTERVILLE one bedroom, furnished. Turcotte Realty, 752-3881.

COLLEGE VIEW APARTMENTS, two bedrooms, unfurnished. Turcotte Realty, 752-3881.

TWO BEDROOM FURNISHED apartment, air condition, private entrance. Call 756-1330.

FURNISHED, NEAR DOWNTOWN and university, couple only. Mrs. D.M. Clark, 752-3447.

Stratford Arms Apts., 1900 S. Charles St. An exclusive community designed to provide the ultimate in gracious living. Modern 1, 2 and 3 bedroom garden apartments and 2 bedroom Townhouses. Furnished or unfurnished. 756-4800.

CHALET APARTMENTS, Winterville, N.C., 3 bedrooms, fully carpeted, stove and refrigerator furnished. Call 746-4310.

2400 E. 10th FURNISHED, suitable for 4 boys, Available June 1. Call 752-4661 or 756-4013.

CLASSIFIED DISPLAY

EQUIPPED WITH
CRAWFORD'S FRESH VEGETABLES
Garden Peas, Collards, Cabbage, and Others in Season.

Located 6 miles west of Greenville on Farmville Hwy. Watch for the sign on the right.

Call 756-2434

RENTALS

Houses for Rent

TWO BEDROOM HOUSE in Ayden, \$75. Call 752-3373.

FOUR ROOM FURNISHED house with air condition. 115 W. Redman Ave., Greenville.

THOMAS REALTY COMPANY PRESENTS . . .
Home Buys of the Season
CHERRY OAKS

TREAT YOURSELF
to an unusual 3 bedroom 2 1/2 bath. Fireplace, central air and all the extras. \$35,300

WE ARE ENTHUSIASTIC
about this 3 bedroom, 3 bath, shag carpet all over, fireplace, central air, 2 car garage, lots of storage. \$36,200

ROOM FOR THE FAMILY
with a 4 bedroom colonial with everything including carpet & central air. \$37,200

A BEAUTIFUL WAY
to live with this 3 bedroom, 2 1/2 baths, quiet bedroom wing, 2 car garage, central air, carpet throughout, and the master bedroom is extra special \$36,200

GLENNWOOD ACRES
YOUR OWN DUCKS
with the quiet setting, 3 bedroom, 2 baths, foyer, formal dining, breakfast room, fireplace, central air and carpet. All built-ins. \$33,500

A LOT OF HOUSE
for the money by the lake. Carpet, central air, pantry, all built-ins. \$32,000

FOR THE SMART YOUNG COUPLE
a new 3 bedroom, 1 1/2 baths, garage and lots of extras. See this \$18,000

A NEW WAY OF LIFE
for the family on a budget. 4 bedrooms, 1 1/2 baths, kitchen & family room combination, garage. New and Nicely Decorated. \$21,000

We Can Answer All Questions that you have About Real Estate.

THOMAS REALTY CO.
106 Greenville Blvd.
756-5166 Days 756-5132 Nights, Weekends
Member MLS

SPECIAL NOTICES

BIDS ARE NOW open for repairs to be made on single dwelling homes owned by the Department of Housing and Urban Development. All dependable contractors who are interested in bidding on this work should call 756-0911 and ask for the Area Broker of the Federal Housing Administration. The hours are 9 a.m. - 5 p.m.

WANTED TWO MILLION people to enter Little Mint Summer time Sweepstakes. Free \$8,000 in prizes, 1972 Mustang, a cruise for two Bermuda, 25" color TV, a trip to Disney World, a mini bike, 35 bicycles, 175 buckets of Little Mint fried chicken. No purchase required. You do not have to be present to win. Register at any Little Mint.

COLOR TV MAKES A GOOD BALL GAME BETTER!

BIDS ARE NOW open for repairs to be made on single dwelling homes owned by the Department of Housing and Urban Development. All dependable contractors who are interested in bidding on the work should call 756-0911 and ask for the Area Broker of the Federal Housing Administration. The hours are 9 a.m. - 5 p.m.

WANTED

Wanted To Buy

MARRIED COUPLE WANTS home in country with bathroom. Will make repairs. Please write James W. Daniels, Rt. 1, Box 18, Robersonville, N.C. 27566.

WANTED, BAND SAW, minimum depth of cut six inches. Call 756-1681.

CLASSIFIED DISPLAY

AMF Electric Start, 8 horse power 36" mower.
\$629.95 plus tax

HENDRIX-BARNHILL CO.
Memorial Drive

BUG LIGHTS, BAGS, & BULBS.
Hendrix-Barnhill Company

THOMAS REALTY COMPANY PRESENTS . . .
Home Buys of the Season
CHERRY OAKS

TREAT YOURSELF
to an unusual 3 bedroom 2 1/2 bath. Fireplace, central air and all the extras. \$35,300

WE ARE ENTHUSIASTIC
about this 3 bedroom, 3 bath, shag carpet all over, fireplace, central air, 2 car garage, lots of storage. \$36,200

ROOM FOR THE FAMILY
with a 4 bedroom colonial with everything including carpet & central air. \$37,200

A BEAUTIFUL WAY
to live with this 3 bedroom, 2 1/2 baths, quiet bedroom wing, 2 car garage, central air, carpet throughout, and the master bedroom is extra special \$36,200

GLENNWOOD ACRES
YOUR OWN DUCKS
with the quiet setting, 3 bedroom, 2 baths, foyer, formal dining, breakfast room, fireplace, central air and carpet. All built-ins. \$33,500

A LOT OF HOUSE
for the money by the lake. Carpet, central air, pantry, all built-ins. \$32,000

FOR THE SMART YOUNG COUPLE
a new 3 bedroom, 1 1/2 baths, garage and lots of extras. See this \$18,000

A NEW WAY OF LIFE
for the family on a budget. 4 bedrooms, 1 1/2 baths, kitchen & family room combination, garage. New and Nicely Decorated. \$21,000

We Can Answer All Questions that you have About Real Estate.

THOMAS REALTY CO.
106 Greenville Blvd.
756-5166 Days 756-5132 Nights, Weekends
Member MLS

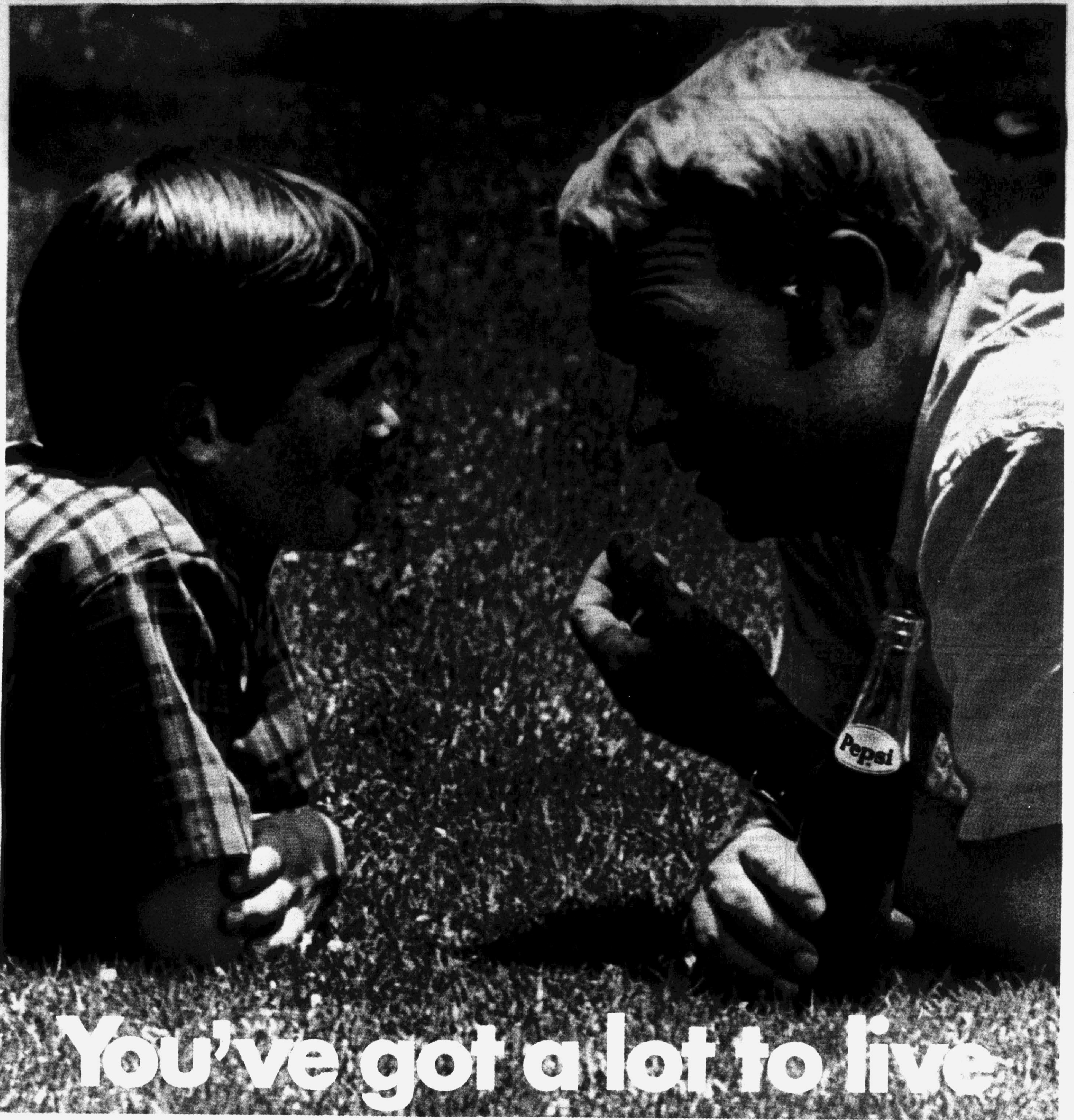

You've got a lot to live

Pepsi's got a lot to give

Those boys of yours. They've got a lot to live. So do you. And your family's a big part of it all. Don't all of you deserve the best? That's Pepsi-Cola. Taste, energy, value...
Pepsi's got a lot to give.

