

8 7 6 5 4 3 2 1

NOTES:

- THIS DRAWING HAS BEEN DEVELOPED FROM SHIPCHECK INFORMATION FOR ACCOMPLISHING THE INSTALLATION OF MODIFIED FUEL SYSTEM TO LCM-8, MOD-1.
- ALL FABRICATION WELDING AND INSPECTION TO BE IN ACCORDANCE WITH NAVSEA 0900-LP-014-5010, WELD SIZED BASED ON USE OF AWS A5.1, CLASS E7018 ELECTRODES FOR LC STEEL TO LC STEEL.
- EQUIPMENT AND WORKMANSHIP SHALL BE IN ACCORDANCE WITH USCG AND ABS REGULATIONS.
- REPAIR ALL PAINT DAMAGED BY THIS INSTALLATION AND PAINT ALL NEW STEEL IN ACCORDANCE WITH U.S. ARMY TECHNICAL BULLETIN TB43-0144.
- MATERIAL ORDERED ON THIS DRAWING IS NOT INTENDED TO BE RESTRICTIVE, SUBSTITUTION OF EQUAL QUALITY MATERIAL MAY BE MADE.
- SLIGHT DEVIATIONS FROM DIMENSIONS SHOWN ARE PERMISSIBLE TO SUIT ACTUAL CONDITIONS FOUND ABOARD THE VESSEL.
- COMPONENTS SHOWN BY SOLID, HEAVY LINES ARE NEW AND ARE TO BE INSTALLED IN ACCORDANCE WITH THIS DRAWING. PHANTOM LINES INDICATE EXISTING COMPONENTS INSTALLED BY DRAWINGS REFERENCED AS NOTED.
- ALL HOSE ASSEMBLIES SHALL BE ADEQUATELY SUPPORTED USING HOSE SUPPORTS, FIND NO. M-13, M-15 AND M-24.
- PIPES OR HOSES OBSCURED BY FLOOR PLATING OR ENGINE ROOM EQUIPMENT SHALL BE IDENTIFIED BY (COPPER, BRASS, CRES) TAGS IN ACCORDANCE WITH MIL-STD-130. TERMINATIONS AND USE SHALL BE CLEAR.

REFERENCE DRAWINGS

NO.	DRAWING NO.	TITLE
1	13226E9462	LCM-8, MOD-1, LABEL PLATE LIST
2	13226E9464	LCM-8, MOD-1, MISC STRUCTURAL DETAILS
3	13226E9471	LCM-8, MOD-1 SALTWATER PIPING ARRANGEMENT

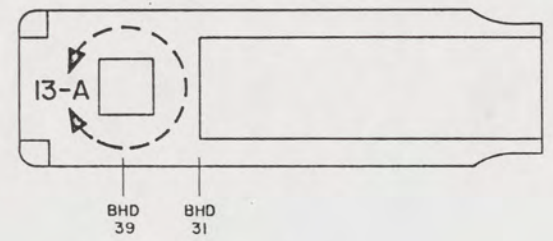

KEY VIEW

THIS DRAWING APPLIES TO HULL NUMBERS 8520 THROUGH 8560 AND 8580 THROUGH 8618 ONLY

YARD	FIND NO.	FSCM	DWG SIZE	PART OR IDENTIFYING NO.	QTY REQD	NOMENCLATURE OR DESCRIPTION	SPECIFICATION	MATERIAL
YARD	M-24	87373		CL-9	AR	SUPPORT, HOSE-1/4" (PH) (SEE NOTE 8)	COML	
YARD	M-23			MS51922-2	4	NUT, HEX, SLFLKG, 1/4 - 20 UNC-2B		CRES
YARD	M-22			MS35307-306	4	SCREW, CAP, HEX HD, 1/4-20 UNC-2A X 3/4" L		CRES
YARD	M-21				2	SH, 1/8" X 4" X 5 1/2"	ASTM A366	STEEL
YARD	M-20	87373		831-4	AR	HOSE, 1/4" ID X 1/2" OD, W.P 350 PSI (P.H)	COML	SYNTH RBR
YARD	M-19	24161		12CIT-12RFJX-12RFJX-102	1	HOSE ASSEMBLY, 3/4" ID X 8'-6" LG (GATES)	COML	
YARD	M-18			MS51922-38	4	NUT, HEX, SLFLKG, 1/2-20 UNF-2B		CRES
YARD	M-17			MS35308-411	4	SCREW, CAP, HEX HD, 1/2-20 UNF-2A X 1 1/4" L		CRES
YARD	M-16				4	PL, 1/4" X 3" X 4 1/4"	ASTM A36	STEEL
YARD	M-15	87373		CL-14	AR	SUPPORT, HOSE-1/2" (P.H) (SEE NOTE 8)	COML	
GFE	M-14	55752		MODEL 1000FG	2	FUEL FILTER/WATER SEPARATOR, 3.16 GPM, 7/8"-14 UNF O-RING PORTS, W/FILTER ELEMENT 2020SM-30 (RACOR)	COML	VARIOUS
SUPPLIER	FIND NO.	FSCM	DWG SIZE	PART OR IDENTIFYING NO.	QTY REQD	NOMENCLATURE OR DESCRIPTION	SPECIFICATION	MATERIAL

SHEETS				STATUS OF REVISIONS		
3	2	ZONE	LTR	DESCRIPTION	DATE	APPROVED
-	-		A	SEE ECP NO. 90HE3102 AND 90HE3103	10 MAR 91	[Signature]

YARD	FIND NO.	FSCM	DWG SIZE	PART OR IDENTIFYING NO.	QTY REQD	NOMENCLATURE OR DESCRIPTION	SPECIFICATION	MATERIAL
YARD	M-13	87373		CL-19	AR	SUPPORT, HOSE-3/4" (P.H) (SEE NOTE 8)	COML	
YARD	M-12				2	PL, 1/4" X 3" X 5 1/2"	ASTM A36	STEEL
YARD	M-11			MS51922-18	8	NUT, HEX, SLFLKG, 3/8"-16 UNC-2B		CRES
YARD	M-10			MS35307-360	8	SCREW, CAP, HEX HD, 3/8-16 UNC-2A X 1" LG		CRES
YARD	M-9				8	PL, 1/4" X 2 1/4" X 2 3/4"	ASTM A36	STEEL
YARD	M-8				4	PL, 1/4" X 2 3/4" X 6"	ASTM A36	STEEL
YARD	M-7	24161		8CIT-8RFJX-8RFJX-120	1	HOSE ASSEMBLY, 1/2" ID X 10'-0" LG (GATES)	COML	
YARD	M-6	24161		8CIT-8RFJX-8RFJX-98	1	HOSE ASSEMBLY, 1/2" ID X 8'-2" LG (GATES)	COML	
YARD	M-5	24161		8CIT-8RFJX-8RFJX-15	2	HOSE ASSEMBLY, 1/2" ID X 15" LG (GATES)	COML	
YARD	M-4	24161		12CIT-12RFJX-12RFJX-28	1	HOSE ASSEMBLY, 3/4" ID X 28" LG (GATES)	COML	
YARD	M-3	24161		12CIT-12RFJX-12RFJX-150	1	HOSE ASSEMBLY, 3/4" ID X 12'-6" LG (GATES)	COML	
YARD	M-2	24161		12CIT-12RFJX-12RFJX-136	1	HOSE ASSEMBLY, 3/4" ID X 11'-4" LG (GATES)	COML	
YARD	M-1	24161		12CIT-12RFJX-12RFJX-34	1	HOSE ASSEMBLY, 3/4" ID X 34" LG (GATES)	COML	
YARD	F-14	98660		PF 101-62	4	BUSHING, REDUCER, 3/8" IPS X 1/8" IPS (FLODAR)	COML	STEEL
YARD	F-13	74400		M-4008	4	PRESSURE SWITCH, FUEL, 1/8-27 NPTF CONNECTOR (HOBBS)	COML	
GFE	F-12	55752		1606B	2	VACUUM GAGE KIT, CONSISTS OF VACUUM GAGE, 0-15 HG 1/4" NPT, W/HOSE FITTING, 1/8" MNPT X #4 AND FEM SWIVEL HOSE FITTING #4 (RACOR)	COML	VARIOUS
YARD	F-11	59257		12-10-SA-6-0E2	2	ELBOW, 90°, STANDARD, 3/4" TUBE TO 5/8" O-RING PORTS, WITH A 1/8-27 NPTF GAUGE LINE CONNECTION PORT (L AND L FITTINGS)	COML	STEEL
YARD	F-10	79470		C5515X12X10	2	ELBOW, 90°, STRAIGHT THD O-RING, 3/4" JIC X 5/8" PORT (WEATHERHEAD)	COML	STEEL
YARD	F-9	98660		PF110-6-4	4	ADAPTER, REDUCER, FEMALE-MALE, 3/8" IPS X 1/4" IPS (FLODAR)	COML	STEEL
YARD	F-8	98660		AC1100-8-8	2	STRAIGHT, TUBE TO FEM PIPE, 1/2" JIC X 1/2" IPS (FLODAR)	COML	STEEL
YARD	F-7	98660		PF101-8-4	2	BUSHING, REDUCER, 1/2" IPS X 1/4" IPS (FLODAR)	COML	STEEL
YARD	F-6	98660		AC2000-8	4	ELBOW, MALE, 90°, 1/2" JIC X 3/8" IPS (FLODAR)	COML	STEEL
YARD	F-5	98660		AC1100-12-8	2	STRAIGHT, TUBE TO FEM PIPE, 3/4" JIC X 1/2" IPS (FLODAR)	COML	STEEL
YARD	F-4	98660		PF101-8-6	2	BUSHING, REDUCER, HEX, 1/2" IPS X 3/8" IPS (FLODAR)	COML	STEEL
YARD	F-3	98660		AC1000-12	2	STRAIGHT, TUBE TO MALE PIPE, 3/4" IPS X 3/4" JIC (FLODAR)	COML	STEEL
YARD	F-2	98660		AC1000-8-8	2	STRAIGHT, TUBE TO MALE PIPE, 1/2" JIC X 1/2" IPS (FLODAR)	COML	STEEL
YARD	F-1	79470		C3309X8	2	COUPLING, STRAIGHT, 1/2" IPS (WEATHERHEAD)	COML	STEEL
YARD	P-1				AR	PIPE, BLACK, SEAMLESS, 1/2" IPS, SCHED 40	ASTM A53	STEEL

UNLESS OTHERWISE SPECIFIED DIM/TOLERANCES ARE: DIM IN. ONE PLACE (.X) ± TWO PLACE (.XX) ± THREE PLACE (.XXX) ± ANGLES ± THIRD ANGLE PROJECTION

DO NOT SCALE THIS DRAWING FOR INTERPRETATION OF DRAWING 000-STD-100 APPLIES REMOVE BURRS AND BREAK SHARP EDGES SHARP EDGES TO FILLET RADI TO

MATERIAL

DRWN BY MTL/HA DATE 19 FEB 87 CHECKED BY C.T. P. 15 NOV 88 CONTRACT NO. DESIGN APPROVAL DATE 15 NOV 88 APPROVED FOR PROCUREMENT DATE

U.S. ARMY BELVOIR RESEARCH, DEVELOPMENT, AND ENGINEERING CENTER FORT BELVOIR, VIRGINIA 22060-5606

LCM-8, MOD-1, FUEL SYSTEM MODIFICATION

SIZE A1 FSCM 97403 DWG NO. 13226E9470 SCALE 1/16 SHEET 1 OF 3

8 7 6 5 4 3 2 1

5

79

16 15 14 13 12 11 10 9

REVISIONS				
NO.	DATE	DESCRIPTION	BY	APP'D

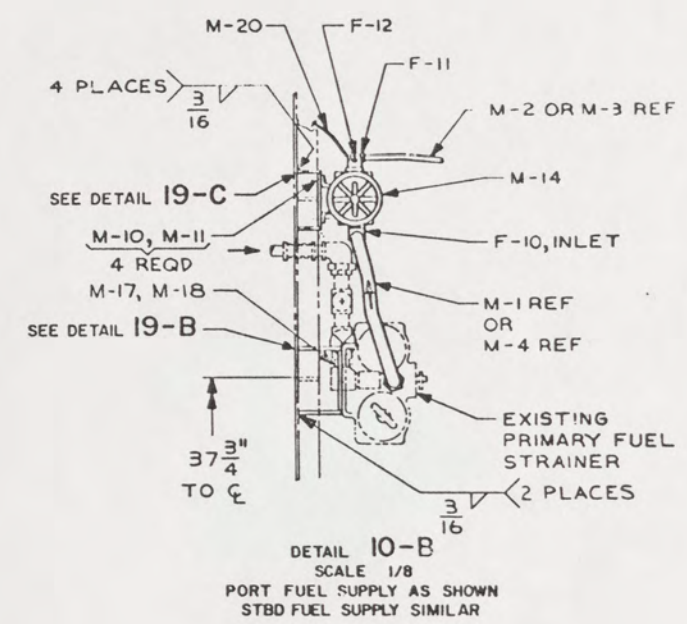
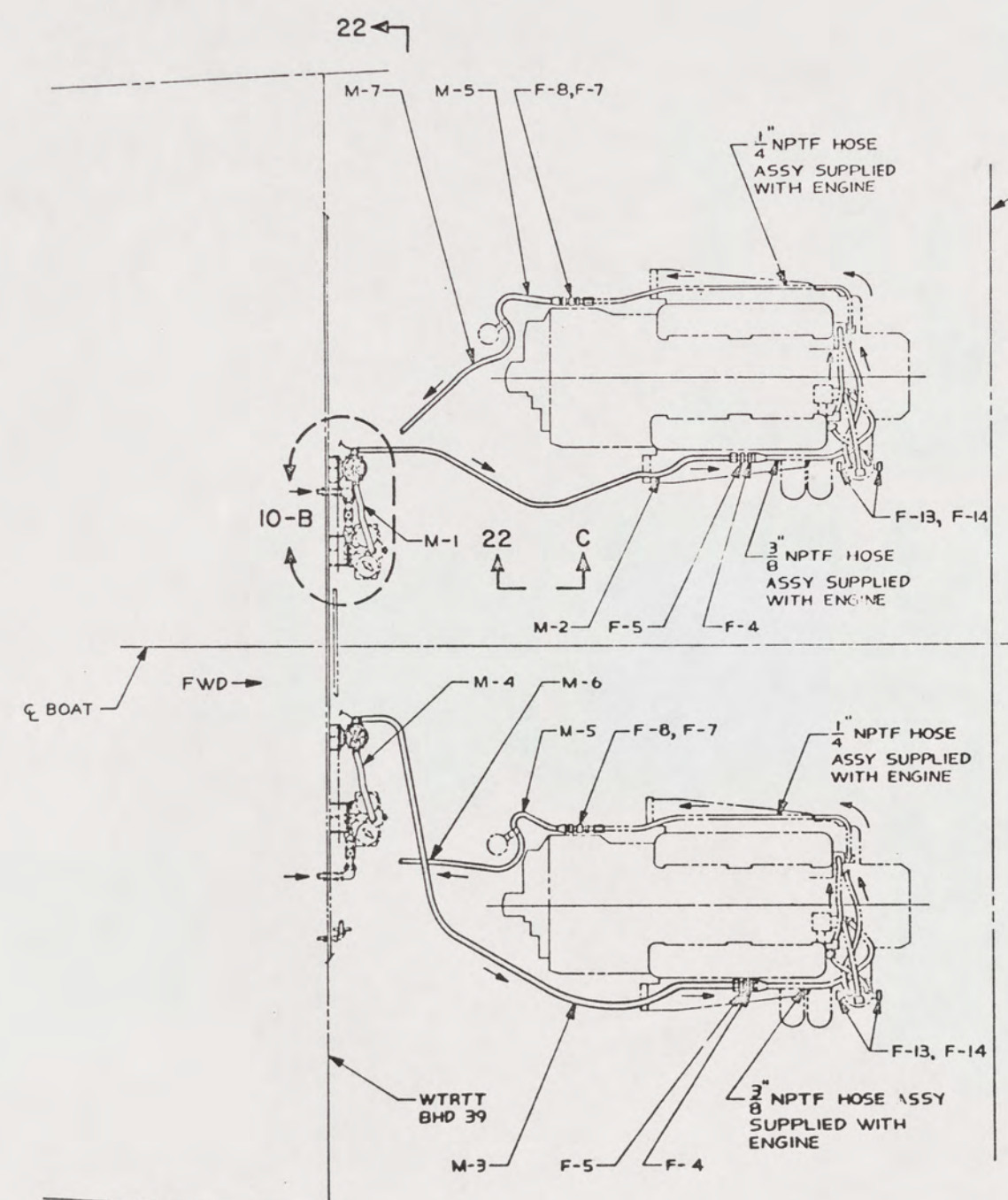

PLAN VIEW 13-A
ITEMS NOT SHOWN
OMITTED FOR CLARITY

UNLESS OTHERWISE SPECIFIED DIM./TOLERANCES ARE: .001 IN.		DRAWN BY HMB	DATE 31 JAN 85	U.S. ARMY MOBILITY EQUIPMENT RESEARCH AND DEVELOPMENT COMMAND FORT BELVOIR, VIRGINIA 22060	
ONE PLACE (1.0) 2	TWO PLACES (1.0) 3	CHECKED BY C.F. PUGH S.S. CUC	15 Nov 88	LCM-8, MOD-1, FUEL SYSTEM MODIFICATION	
THREE PLACES (1.0) 4	FOUR PLACES (1.0) 5	THIRD ANGLE PROJECTION	CONTRACT NO.		
DO NOT SCALE THIS DRAWING		DESIGN APPROVAL <i>Robert D. Ditt</i>		SIZE A1 97403	
REMOVE DIMS AND BREAK SHARP EDGES		DATE 1 MAR 88			
SHARP EDGES TO		APPROVED FOR PROCUREMENT <i>Paul H. ...</i>		DWG NO. 13226E9470	
FILLET RADIUS TO		DATE 25 Nov 88		SHEET 2	
WATERFALL		SCALE			

80

16 15 14 13 12 11 10 9

24 23 22 21 20 19 18 17

FORM	LTR	DESCRIPTION	DATE	APPROV

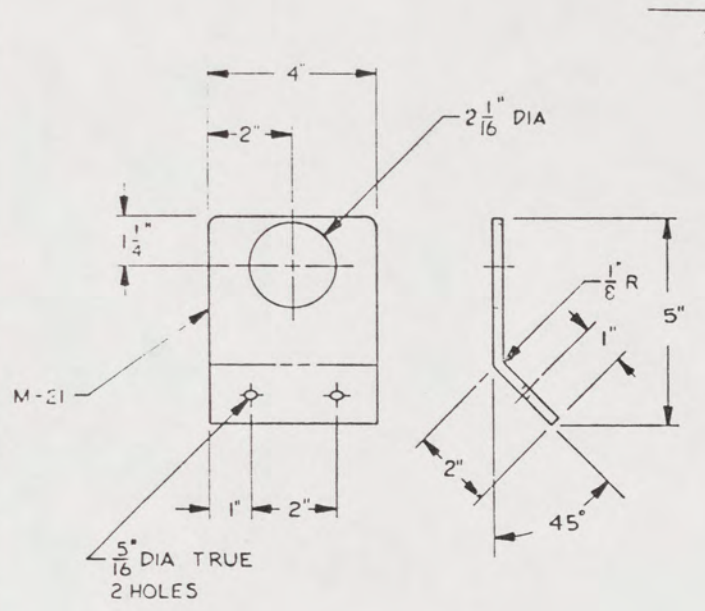

DETAIL 24-C
SCALE 1/2
2 PLACES

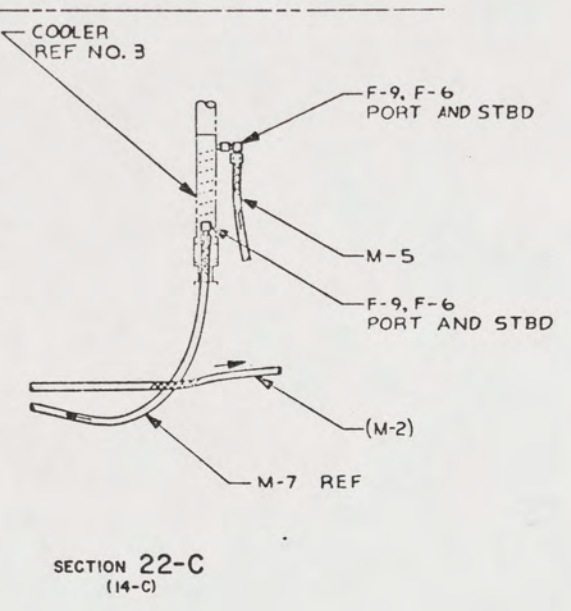

SECTION 22-C
(14-C)

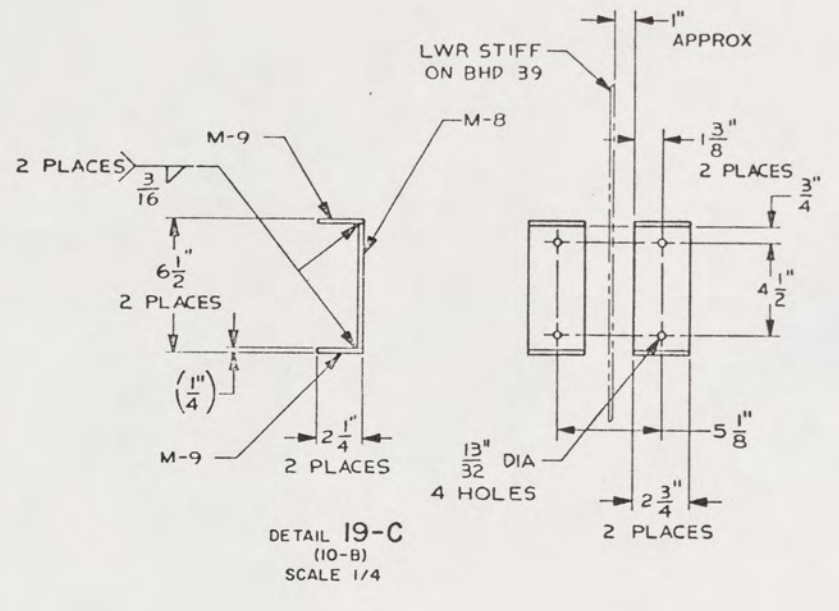

DETAIL 19-C
(10-B)
SCALE 1/4

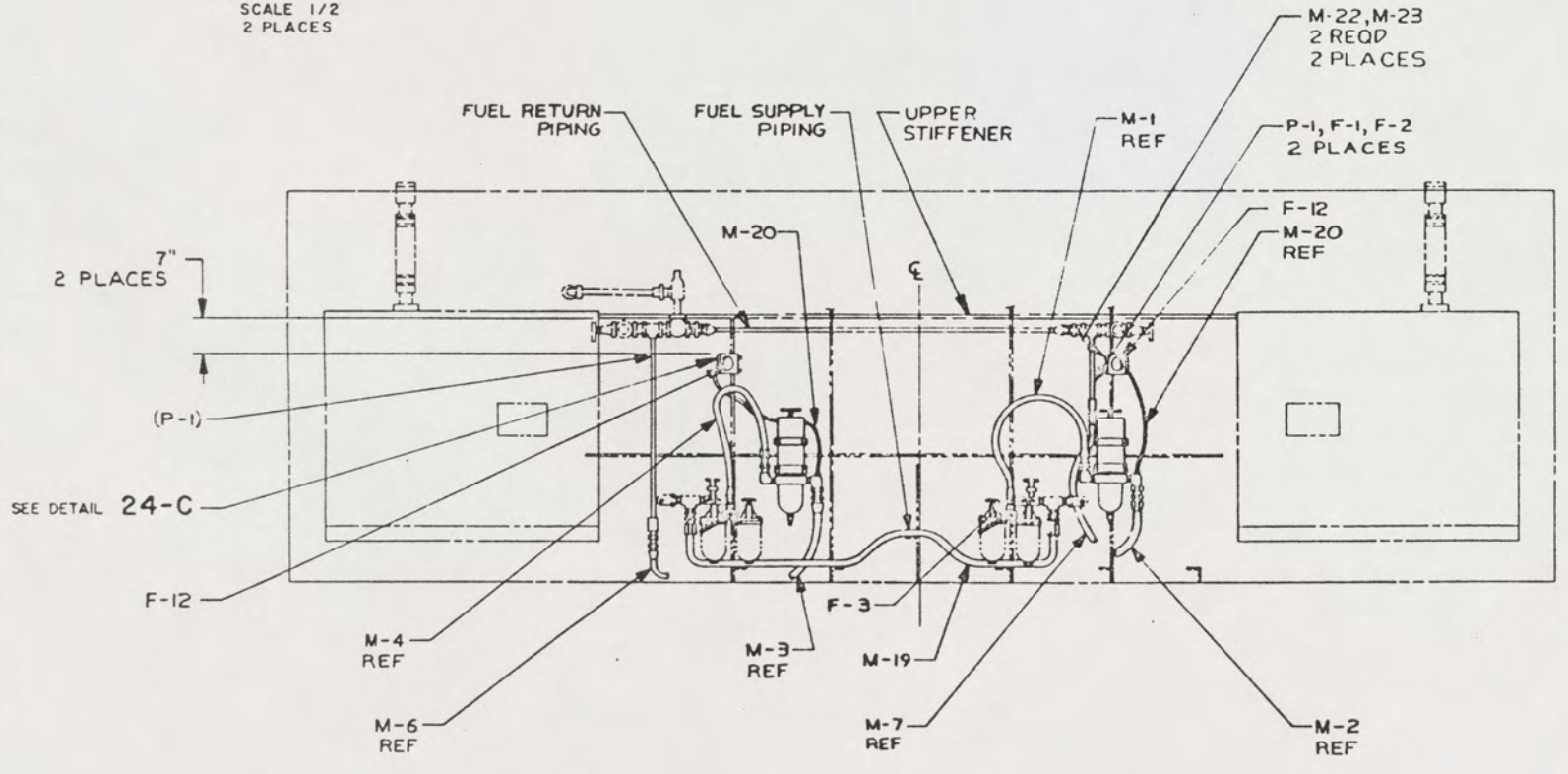

VIEW 22-A
(14-D)
ROTATED 90° CW
VIEW ON BHD 39 LOOKING AFT

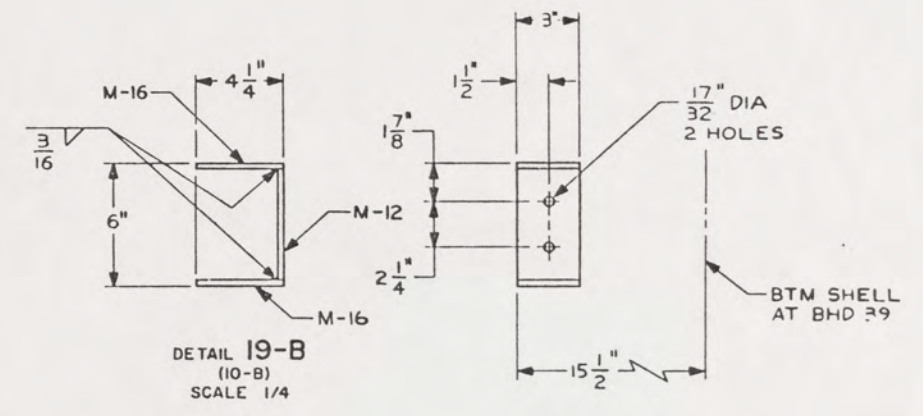

DETAIL 19-B
(10-B)
SCALE 1/4

UNLESS OTHERWISE SPECIFIED DIM/TOLERANCES ARE		DRAWN BY	DATE	U.S. ARMY MOBILITY EQUIPMENT RESEARCH AND DEVELOPMENT COMMAND FORT BELVOIR, VIRGINIA 22060	
ONE PLACE () 0	TWO PLACE () 0	HMD	24 JAN 85	LCM-8, MOD-1, FUEL SYSTEM MODIFICATION	
THREE PLACE () 0	FOUR PLACE () 0	CHECKED BY C.F. PUGH	15 NOV 84		
DO NOT SCALE THIS DRAWING		THIRD ANGLE PROJECTION	CONTRACT NO.	SIZE	ITEM NO.
FOR INTERPRETATION OF DRAWING/STANDARD 100 APPLIES		DESIGN APPROVAL	DATE	A1	97403
REMOVE BORDERS AND BREAK SHARP EDGES	GROUP EDGES TO	DATE	15 NOV 84	13226E9470	
TILET EDGES TO	DATE	APPROVED FOR PROCUREMENT	DATE	SCALE	
MATERIAL	DATE	DATE	15 NOV 84	SHEET 3	

81